

**Rollei**  
fototechnic

**Rolleiflex 6008 SRC 1000**

**Rolleiflex 6008**

**User's Manual**



# Contents

Components and controls	page 2
In a nutshell	page 5
Camera operation	page 10
Interchangeable modules	page 22
Hints and notes	page 27
Main accessories	page 32
Lens table	page 36
The Rolleiflex 6008 system	page 37
Trouble shooting	page 40
Technical data	page 46
What is where	page 49

## IMPORTANT SAFETY INSTRUCTIONS

When using your photographic equipment, basic safety precautions should always be observed, including the following:

Read and understand all instructions before using.

Close supervision is necessary when any appliance is used by or near children. Do not leave appliance unattended while in use.

Care must be taken as burns can occur from touching hot parts.

Do not operate appliance with a damaged cord or if the appliance has been dropped or damaged – until it has been examined by a qualified serviceman.

Position the cord so that it will not be tripped over, be pulled, or contact hot surfaces.

If an extension cord is necessary, a cord with a current rating at least equal to that of the appliance should be used. Cords rated for less amperage than the appliance may overheat.

Always unplug appliance from electrical outlet before cleaning and servicing and when not in use. Never yank cord to pull plug from outlet. Grasp plug and pull to disconnect.

Let appliance cool completely before putting away. Loop cord loosely around appliance when storing.

To protect against the risk of electric shock, do not immerse this appliance in water or other liquids.

To avoid the risk of electric shock, do not disassemble this appliance, but take it to a qualified serviceman when some service or repair work is required. Incorrect reassembly can cause electric shock when the appliance is used subsequently.

The use of accessory attachments not recommended by the manufacturer may cause a risk of fire, electric shock or injury to persons.

Connect this appliance to a grounded outlet.

## KEEP THESE INSTRUCTIONS SAFE

1 2 3 4 5 6 7 8

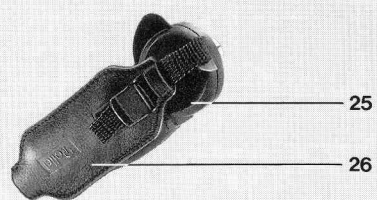
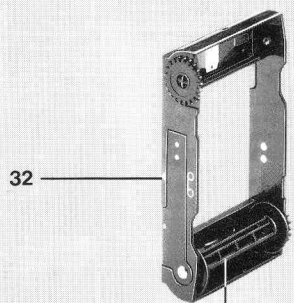
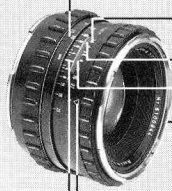
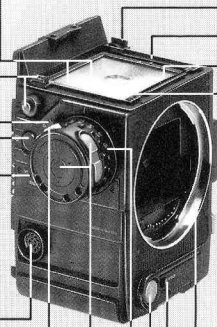
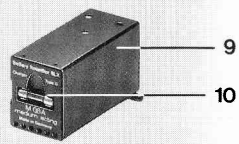
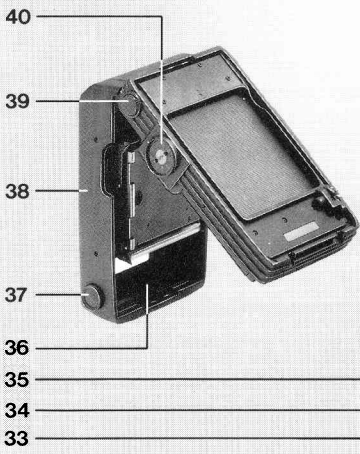

28  
29 27  
30

31

# Components and controls

- 1** Main switch
- 2** Righthand finder hood release catch
- 3** Righthand carrying strap fixture
- 4** Flash ready signal
- 5** Righthand screen frame lug
- 6** Magnifier panel
- 7** Magnifier
- 8** Folding finder hood cover
- 9** Rechargeable NiCd battery pack
- 10** Fuse
- 11** Lefthand finder hood release catch
- 12** Lefthand screen frame lug
- 13** Finder LED display strip
- 14** Battery check LED
- 15** Distance scale
- 16** Aperture scale
- 17** Aperture pointer
- 18** Pointer scale
- 19** Double filter bayonet mount
- 20** Aperture index mark
- 21** Distance setting index and depth-of-field scale
- 22** Camera bayonet mount
- 23** Release lock for 24
- 24** Bottom right body release
- 25** Action grip
- 26** Removable leather strap
- 27** Shutter speed dial
- 28** Top right shutter release key
- 29** Fixing point for action grip
- 30** Meter/memory key (AE lock)
- 31** Empty takeup spool
- 32** Loading alignment marker for arrows on backing paper
- 33** Universal remote outlet with screw thread
- 34** Display on/off switch
- 35** Depth of field preview/stopdown key
- 36** Spool chamber and symbol for empty takeup spool
- 37** Righthand release key to open magazine back for loading
- 38** Magazine back section
- 39** Righthand magazine release key
- 40** Film speed setting dial

- 41 Spare fuse
- 42 Fuse retaining panel
- 43 Interchangeable focusing screen
- 44 Removable folding hood
- 45 Lefthand carrying strap fixture
- 46 Exposure correction dial
- 47 Meter mode selector
- 48 Multi-exposure knob
- 49 Lefthand magazine release key
- 50 Sticker recess
- 51 Drawslide bar
- 52 Interchangeable film magazine
- 53 Frame counter window
- 54 Window for film box tab
- 55 Lefthand release key to open magazine back for loading
- 56 Magazine hinge bar
- 57 Spring bar of film spool shaft
- 58 Channel for film box tab
- 59 Film insert
- 60 Film transport gear
- 61 Film path marking
- 62 Quick tripod coupling
- 63  $\frac{3}{8}$  in. tripod bush
- 64  $\frac{1}{4}$  in. tripod bush
- 65 Battery pack compartment
- 66 Release for grip adjustment
- 67 Fixing shaft of action grip
- 68 Lens bayonet mount
- 69 Interchangeable lens
- 70 Aperture ring
- 71 Release catch for manual aperture settings
- 72 Focusing mount
- 73 Lens release catch
- 74 Mirror prerelease
- 75 X synch flash cable socket
- 76 Hot shoe with dedicated flash contacts
- 77 Cable release socket
- 78 Battery pack grip bar

# Rolleiflex 6008

## By way of introduction

To make the most of the scope of this camera you need a certain level of photographic expertise and basic technical knowledge. We assume that a Rolleiflex 6008 owner will have that basic knowledge; this instruction manual aims to provide the necessary camera handling information.

We start by presenting the components and controls, followed by a brief summary of the main handling points.

The main section describes and illustrates the camera features and operation in detail. It does so in a practical sequence, starting with the steps of assembling the camera modules and film loading through shooting to unloading the exposed film.

Then follow practical hints and notes, a collection of camera operation details, and notes on main accessories.

The tables list main data of the interchangeable lenses.

A trouble shooting table helps to trace possible problems and handling errors and indicates remedies.

The numbering of the controls and components is consistent throughout the text and illustrations. It is based on the two fold-out picture plates at the front and back. Keep them folded out for easy reference while reading this manual.

**Rollei**  
rolleitechnik

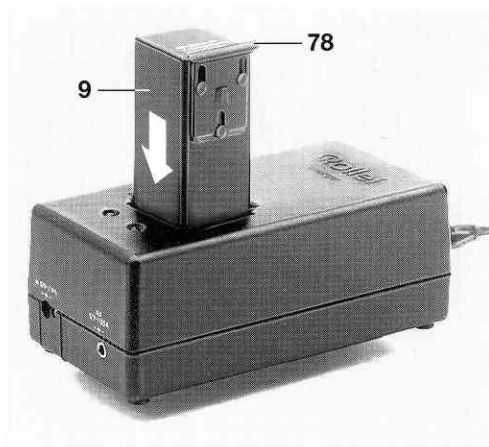

## In a nutshell

Instant information: Read this telegram style summary for a quick grasp of the main camera controls and operations. To get to know the camera in depth, go to page 10 and read on from there.

**Note for owners of a Rolleiflex 6002 or SLX:**  
**Except for the camera back, all interchangeable modules may be used on the Rolleiflex 6008.**  
**Do not however try to use the interchangeable 6008 magazines on a Rolleiflex 6002 or SLX – the motorised drive system of these models is not designed for operation with interchangeable magazines. Also, the film track does not in that case keep the film fully flat.**

### Charge battery pack

Insert the mains cable c the charger mains socket d and connect to the mains. The green LED indicates the “ready” status. All common mains AC voltages and mains frequencies can be used: 100 V mains voltage – 240 V AC and 50 Hz mains frequency – 60 Hz. Push up grip bar 78, withdraw battery pack 9 from camera and insert in charger in position shown. Loading time: Minimum 10 min, normal 1 hour.

**All rechargeable NiCd batteries are subject to gradual self-discharge. To maintain the camera always ready for action, recharge the battery pack – even when not in use – at least every 2–3 months.**

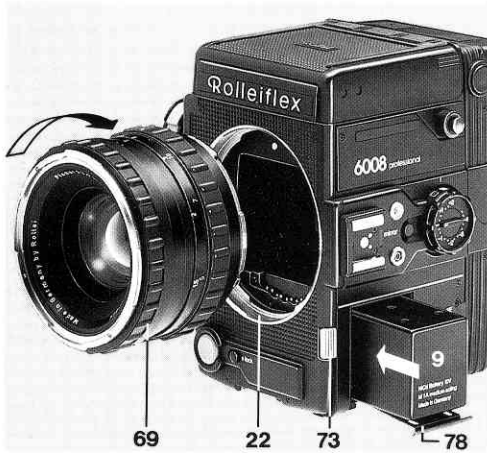

### Fit lens

If no lens is fitted: Press red lens release catch 73 inwards towards body, and turn body cap 78 anticlockwise to remove.



To fit any lens 69, align red mark on bayonet mount 68 with red dot inside camera's bayonet mount 22, insert lens all the way and turn clockwise to engage catch.

### Fit battery pack

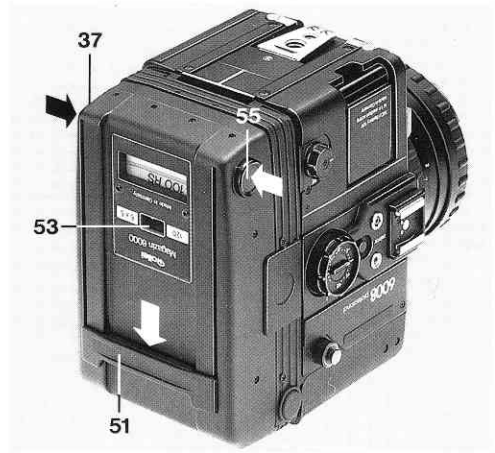
Hold charged battery pack 9 with grip bar downwards and push fully into camera to engage grip bar.



### Load film

Push drawslide bar 51 on film magazine all the way to "magazine change" (arrows). Hold camera upside down as shown. Depress both release keys 37 and 55, open magazine back section 38 and lift out film insert 59 (page 7, top left). Pull red tab of spring bar 57 outwards to insert film spool, oriented as marked by symbol 61. Run paper leader straight to empty spool 31, attach and wind up till arrow heads on backing paper line up with white marker 32 (centre and bottom, page 7). Push film box tab into slot 58 (behind full spool). Drop film insert into back. Full spool must face , empty spool  symbol.

Note: The backing paper must lie *above* pressure plate springs **a** (it gets threaded underneath automatically later). Firmly close magazine back.

Fully push down drawslide bar and set ISO film speed on magazine dial 40. Turn main switch 1 to "S" and press release 24 or 28: Film now runs up to first frame, as shown by No. 1 on frame counter 53. If No. 1 fails to appear, press release once more.

For loading magazines off the camera see "Changing magazines" on page 22.



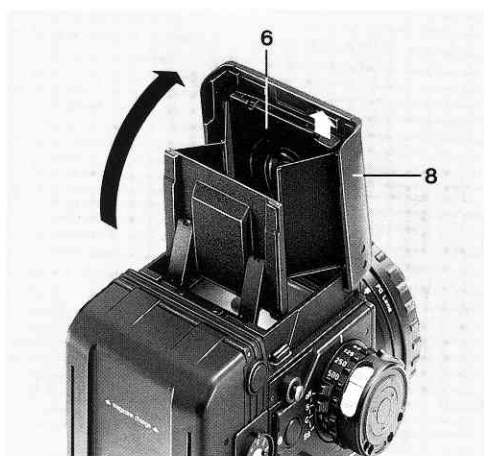
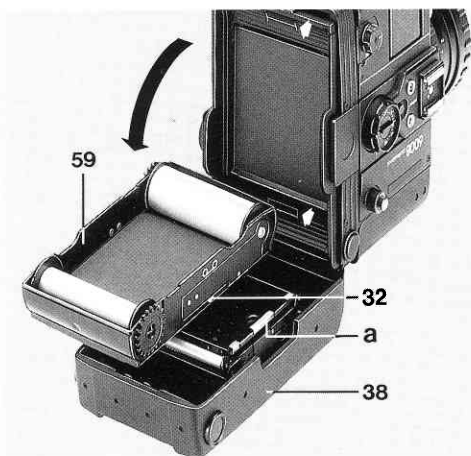

### Focus

Open finder hood 8 and swing up magnifier panel 6 by tab at side. Focus by turning lens's focusing mount 72.

### Select exposure mode

*Aperture-priority AE:* Set shutter speed dial 27 to "A", press release catch 71 on aperture ring 70 and set latter to required aperture.

*Shutter speed-priority AE:* Set aperture ring 70 to "A" and preset shutter speed on dial 27.

*Programmed AE:* Set both aperture ring 70 and shutter speed dial 27 to "A". Program operates mostly with  $1/25$  sec shutter speed priority.

*Manual mode:* Adjust aperture and/or speed till only green LED stays lit.

### Select metering mode

Set selector 47 to one of following:

- Centre-weighted multi-zone readings for normal subjects.
- Spot readings for abnormal brightness distribution.
- ⊞ Multispot readings for extreme brightness ranges; read up to 5 subject points (see page 17).

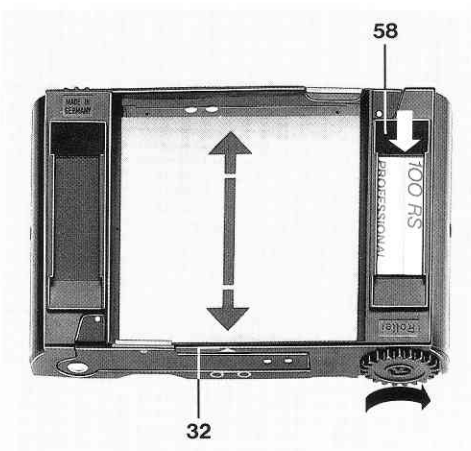
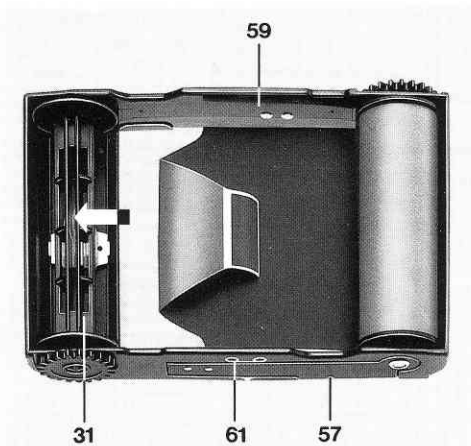

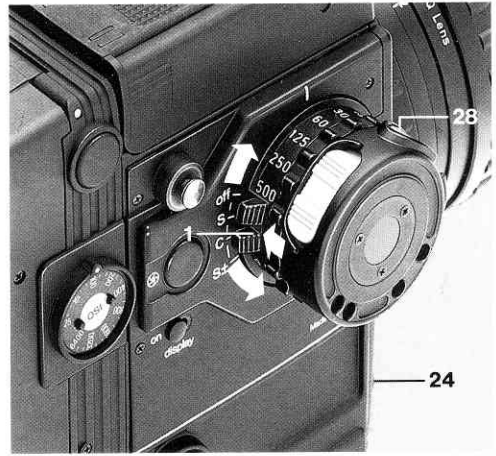
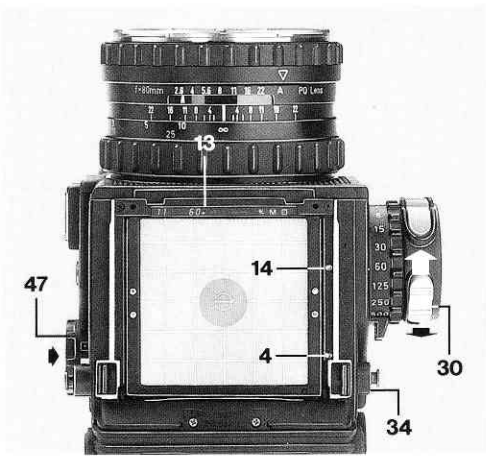

**Read exposure**

After selecting exposure control and meter mode, switch on by pushing meter key 30 forward. Finder displays light for about 20 sec. Reactivate meter system as often as needed. To store reading, hold key 30 depressed or engage by pulling backwards.

**Note finder signals**

Display strip 13 above screen shows main camera functions: Apertures and speeds plus intermediate 1/3 steps up or down; balance signals (manual mode) with green correct-exposure LED. At righthand end +/- stands for exposure correction, M for memory lock and  $\square$  for spot or multi-spot readings. Red LED 14 along righthand edge indicates battery charging state, green LED 4 flash readiness with dedicated flash. Switch 34 switches off display if not wanted.

**Expose**

For single frames depress main switch 1 and turn to engage at "S"; press release 24 or 28. For continuous sequences turn switch 1 to "C" and keep release depressed for required number of exposures. With switch 1 at "off", both releases are locked. Button 24 has additional mechanical lock.

Other ways of releasing: Screw cable release into socket 77 or plug accessory electric remote release into remote outlet 33.

**Note frame counter**

Window 53 shows number of exposures made. "S" indicates no film or film not threaded; red arrow head = film not advanced to first frame; all-red window = backing paper trailer or film spooled up.

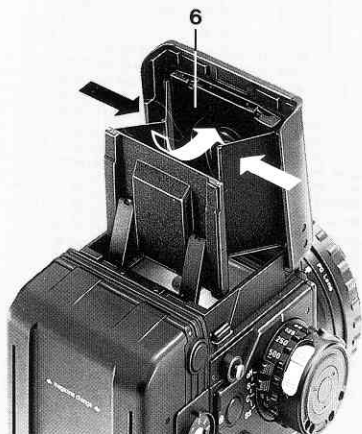

### **Close focusing hood**

Fold down magnifier panel 6 against inside.  
Push in both side panels and let go; hood closes  
on its own.

### **Unload film**

Film end winds up automatically after last exposure.  
Then open magazine back and lift out film insert.  
Remove and seal full film spool. Replace film insert  
and close magazine back.

**Note:** Before opening the magazine back section 38,  
always push drawslide bar 51 all the way to “magazine  
change/remove insert” (arrows). If this is not done,  
the drawslide can be damaged.

**The following pages describe all the camera  
functions and operating steps once more in  
detail.**

**For useful hints see page 27.**

**In case of malfunction or handling errors check  
the trouble shooting tables on pages 40–45.**

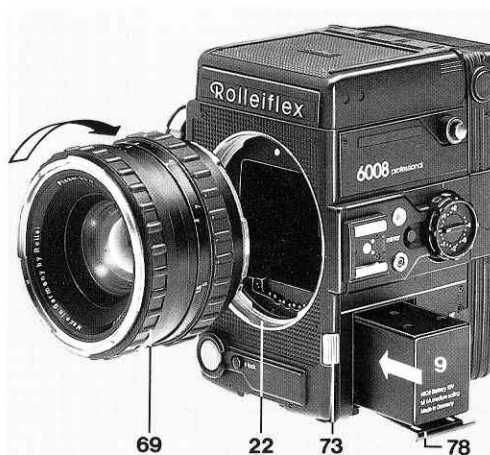

## Camera operation

We now look at the operating sequence from assembling\* the camera elements to unloading the exposed film. This applies to the basic camera outfit and to single exposures with automatic exposure control. Where necessary, more detailed explanations follow the description of the handling steps.

**Rolleiflex 6006 owners please note:**  
**With a few exceptions all interchangeable components are equally usable on the Rolleiflex 6008. Exceptions are the bellows unit, extension tubes, tele converter, retro adapter and magnifying finder hood. If required, Rollei can modify these items. This also applies to the same Rolleiflex 6002 and SLX accessories.**

**Rolleiflex 6002 and SLX owners please note:**  
**Do not try to use the interchangeable 6008 magazines on a Rolleiflex 6002 or SLX – the motorised drive system of these models is not designed for operation with interchangeable magazines. Also, the film track does not in that case keep the film fully flat.**

### Preparing the camera for use

**Fitting the lens:** Press in the red lens release catch 73 and turn the body cap anticlockwise to remove. Remove the front and rear caps from the lens. Align the red mark on the lens 69 with the red dot inside the camera's bayonet mount 22, insert the lens all the way and turn clockwise to engage.



### Inserting the battery pack

Push the battery pack 9, with the grip bar 78 facing down, all the way into the battery compartment 65. Push home the grip bar.

### Fitting the carrying strap

Push the self-latching carrying strap eyelets over the fixtures 3 and 45 and let them engage.

To release the strap, lift the latching bar and unhook the strap eyelets.

The strap can rotate freely around the strap fixture; that makes it easy to carry the camera in any position.

\* The basic camera outfit is supplied in a special packing that securely holds all components. Preferably keep this packaging in case you wish to post or ship the camera outfit again. Carefully note also the serial numbers of the camera body and lenses. If you should ever lose any item the numbers will help to trace it and to prove your ownership.



### Fitting and removing the action grip

To avoid accidental exposures while fitting or detaching the action grip, turn the main switch 1 to "off".

To fit the grip, turn the shutter speed dial 27 past B to the red < > mark and hold it there (against spring pressure). Push the fixing shaft 67 of the grip 25 into the fixing point (central opening) 29 of the dial 27 and push home till it engages. Let go of the dial 27 – it returns from the < > position. The grip is now firmly attached to the camera.

To remove the grip, turn the shutter speed dial 27 to the red < > mark and pull the grip away from the dial.

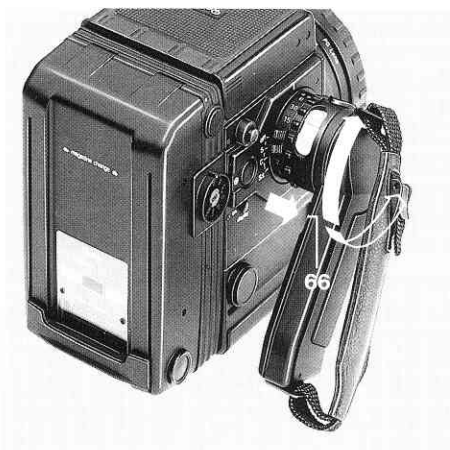

### Adjusting the grip position

The action grip engages in four positions for convenient camera holds with the hood (waist-level shooting) and at eye level with the 45° and 90° prism finders.

To adjust the grip, depress the inside release button 66 till you can move the grip. Let go of the button and swing the grip forward or back till the locking pin engages.



### Adjusting the strap

Open the clip on the strap and lengthen or shorten the latter so that it comfortably supports the camera on your right hand.

To remove the strap altogether, use a ballpoint pen or similar pointed object to depress the small locking pins at each end of the grip while you pull the small strap brackets out of their slots.

When fitting the strap, note that the longer straight bracket goes at the bottom of the grip and the shorter angled one at the top. Again depress the locking pins while inserting the strap brackets in the grip and check that the pins reengage.

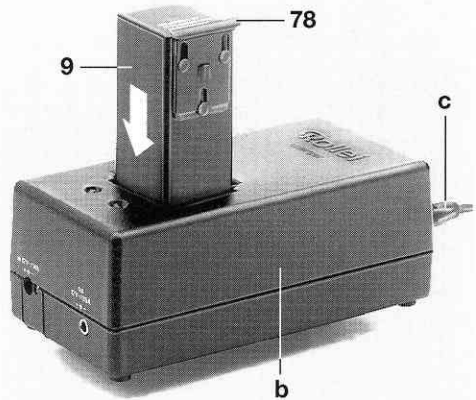

### Charging the battery pack

Insert the mains cable c in the charger mains socket d and connect to the mains. The green LED indicates the "ready" status.

All common mains AC voltages and mains frequencies can be used:

100 V mains voltage – 240 VAC  
50 Hz mains frequency – 60 Hz

Push up grip bar 78 and withdraw battery pack 9 from the camera. Insert the battery in the charger b so that the battery terminals and charger pins are in contact. After 2 seconds, the rapid charging process begins, and the red LED lights up. Rapid charging takes place with a current of approx. 500 mA. The red LED goes out at the end of charging.

The cut-off voltage and the battery temperature are monitored during the charging process. When the cut-off voltage is reached, the unit switches to float charging. If the battery temperature exceeds +45°C, the red LED goes out and rapid charging stops until the temperature is again within the permitted range. The rapid charging process is terminated after a maximum of one hour.

With float charging, the current is introduced in 0,1 second pulses of 500 mA, every 16 seconds, with the red LED switching to the green LED. As the float charge only compensates the spontaneous discharge of the battery, the battery can remain on the charger for a longer time.

Ambient temperature range: approx. 5°–35°C.

The total charging period depends on the charge state of the battery.

After normal discharge, about 1 hour or less is sufficient.

**Hint 1:** If the rapid charging process is started again(!) after the change-over to float charging, remove the battery from the contact pins for a short time and press → again. The 1-hour timer starts and the rapid charging process begins.

**Hint 2:** If the battery is overheated, the red LED will not light up when the battery is inserted. The rapid charging process can only be started after the battery has cooled to below 45°C.

### Car battery connection

Using a connecting lead (which can be purchased as an accessory), connect the lighter socket to the low-voltage socket on the battery charger. Normal charging from a 12 V car battery takes around 14 hours. In this case the red/green indicators do not light up.

### Video camera connection

ACCd video camera or other unit (portable radio), which operates at 12 V/500 mA, can be connected to the 3.5 mm jack bush. The green LED indicates the "ready" status.

### Safety

AT 800 mA fuse unit is permanently fitted in the charger. The outlets (battery pins, sockets) are protected against shorting as a result of a faulty battery or contact with a metallic object. The battery temperature is monitored and limited. For rapid charging, the charging times is monitored and limited. For rapid charging, the charging time is monitored and limited to 1 hour. The control unit complies with the requirements of the safety authorities.

The unit is double-insulated.

Please do not earth this unit. Do not put any bare metallic objects in the battery compartment and only use the charger in a dry environment.

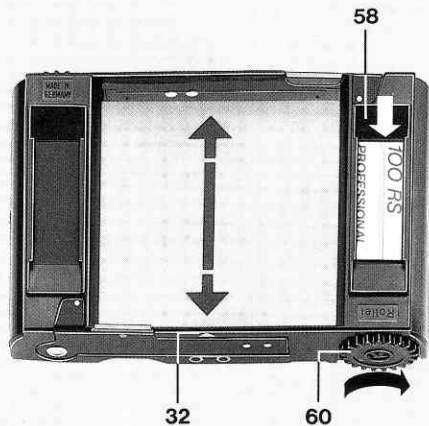
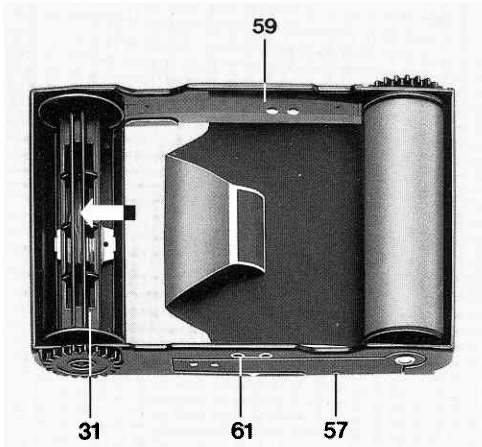

**To avoid excessive drain on the battery pack, always switch off the camera after use: Turn the main switch 1 to "off" and disengage the AE lock key 30 (if engaged).**

**Rechargeable NiCd batteries are subject to gradual self-discharge. To maintain the camera always ready for action, recharge the battery pack – even when not in use – at least once every 2–3 months.**

### Battery check

On switching on, the camera automatically checks the state of the battery. If the remaining battery charge is OK, LED 14 does not light up.

If the LED 14 lights up (red), the battery has only enough power for a few exposures – recharge the battery pack. If the battery power is insufficient for the next exposure and film transport cycle, the camera cuts out altogether; in that case neither the LED 14 nor any other finder display will light.

### Loading the film insert

Push the magazine drawslide bar 51 all the way to "magazine change/remove insert" (arrows).

Depress the keys 37 and 55, swing open the magazine back 38 and remove the film insert 59. For easier removal grip the insert through the cutouts in the sides of the back section 38. First raise the insert end nearer the hinge and lift clear.

Pull outwards the red spring bar 57 at the spoolless end, insert the full film spool as shown by the film

path marking 61 (black side of the backing paper facing inwards) and let the spring bar engage the spool. Run the backing paper straight to the empty takeup spool 31, thread into the spool slot and wind up a turn or two with the transport gear wheel 60. Wind up more backing paper until the large arrow marks on the back of the paper line up exactly with the marker 32 on the insert. Push the identifying tab from the film box into the channel 58 (behind the full film spool) as a film type indicator.

The film insert is symmetrical – either end can take the feed or the takeup spool. There is thus no need to move the empty spool to the other end for loading.

The camera comes complete with one film insert. For efficient operation at extended shooting sessions it makes sense to carry several film inserts – or of course additional interchangeable magazines. You can carry the inserts preloaded for quick film changing. The same film insert (but not the same magazine) serves for both No. 120 and 220 rollfilm.

**Do not use film inserts of the Rolleiflex SLX (with index marks and symbols on the inside edges) as they could jam when unloading.**

At freezing temperatures (below 0°C) it is better not to preload film inserts – rather load the film directly into the camera and advance to frame No. 1. For the adhesive tape that attaches the film to the backing paper may become brittle in the cold and then cause film transport problems.

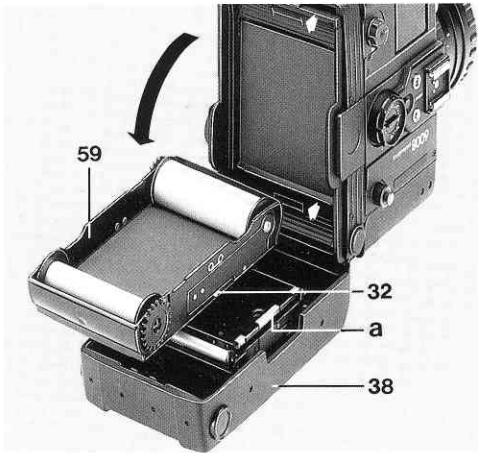

### Replacing the film insert

Open the magazine back as described earlier and drop in the film insert so that the full film spool faces the  $\text{—|}$  symbol (nearest the hinge) in the magazine and the empty spool the  $\text{—|—}$  symbol. (The end with the empty spool drops on top of the window 54.) For easy insertion be sure that the magazine back is fully open and fit the insert end with the empty spool first; then let the end with the full spool drop in. (You will get the knack of it after a few times.)

Do not try to guide the film edges underneath the springs **a** along the pressure plate edges, but let them lie on top. The loading system ensures correct film location and threads the film automatically underneath the springs **a**.

Fully close the magazine back 38 till it engages. Push the drawslide bar 51 all the way down (past the window 54) to disengage the shutter lock. Turn the main switch 1 to "S" and briefly press the shutter release 24 or 28. This makes the film run up automatically to the first frame; No. 1 should appear in the frame counter window 53. If "1" fails to appear (which may occasionally happen with some film brands), simply press the shutter release a second time.

See also page 22 for switching film inserts.

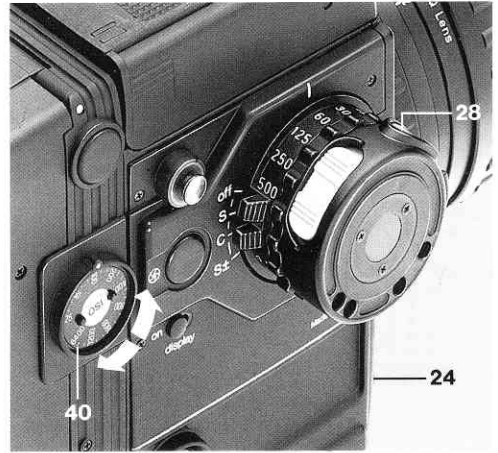

### Setting the film speed

On the magazine turn the film speed dial 40 (by its two protruding pins) to the ISO speed of the film in the camera. The dial clicks at each setting; do not try to set intermediate values.

The film speed setting range runs from ISO 25 to 6400 – which covers virtually all films on the world market. With the exposure correction dial 46 you can correct the normal exposure over a range from  $-4\frac{2}{3}$  to  $+2$  EV in  $\frac{1}{3}$  steps.

**Note:** When you fit interchangeable Rolleiflex 6006 magazines – which have no built-in film speed setting – the camera assumes a default setting of ISO 100. With films of other speeds change the setting of the exposure correction dial 46; this can handle films from ISO 25 to 2500. For instance:

ISO	25	50	100	200	400	800	1600	2500
EV corr.	+2	+1	0	-1	-2	-3	-4	$-4\frac{2}{3}$



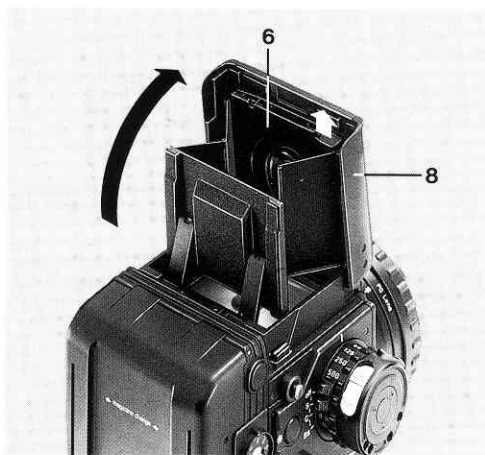

### Opening the hood

Raise the folding hood cover 8 at the rear and swing up. To raise the magnifier panel 6 push up its tab towards the edge of the cover. A spring holds the panel in either the up or down position.

### Closing the hood

Fold down the magnifier panel 6 against the inside. Push in both side panels and let go; the hood closes on its own.

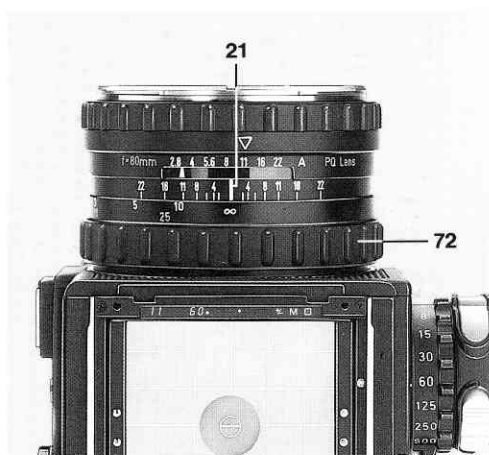

### Focusing

Turn the focusing mount 72 to make the image appear sharp on the focusing screen. You can read off the distance setting in m or ft against the index 21. Check the depth of field against the double aperture scale to each side of the distance index 21. For shots on infrared film read off the focused distance and set it against the red index line (rather than the central index) on the depth-of-field scale. All lenses are always focused at full aperture.

The standard focusing screen incorporates three focusing aids: a central split-image rangefinder, a microprism ring and the Fresnel ground glass itself. This standard screen is ideal for many subjects. There are five further alternative screens for special applications.

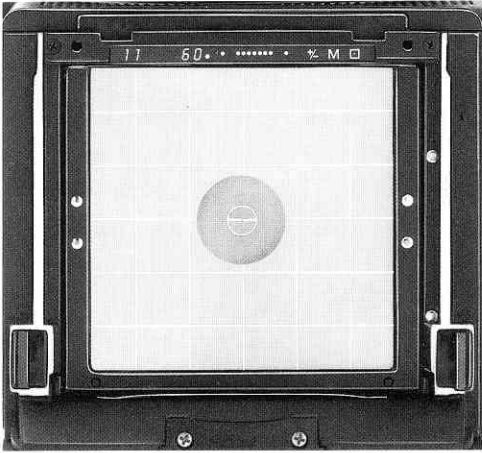

### Viewing

The square line grid of the standard screen also helps vertical and horizontal camera alignment. The lines are spaced 10 mm apart which helps to mark smaller finder fields for 4.5×6 cm (1¾×2¼ in.) upright or horizontal image formats or even 4×4 cm. A special screen with such frame markings is in preparation.

From a given viewpoint, lenses of shorter or longer focal length widen or narrow the field of view respectively. Interchangeable lenses are available in focal lengths from 30 to 1000 mm.

Interchangeable finders, as alternatives to the standard folding hood, are a rigid magnifying hood and two rotating prism finders with a 45° and a 90° eyepiece respectively.

### Exposure control modes

Selecting the automatic exposure (AE) mode is straightforward and logical:

**Aperture-priority AE:** Turn the shutter speed dial 27 past the "500" setting to "A". Press the release catch 71 on the aperture ring 70 and set the latter to the required aperture. The ring engages at 1/3 f-stop intervals.

**Shutter speed-priority AE:** Turn the aperture ring to engage at "A" and select the required shutter speed on the speed dial 27. (Fractions of a second in



white, full seconds in green.) The dial engages at 1/3 step intervals.

**Programmed AE:** Set both the aperture and shutter speed to "A". The program then selects both for a correct exposure. To minimize the risk of camera shake, the program runs with full-aperture priority between 30 and 1/125 sec, then switches to shutter speed priority.

*Typical program* for 80 mm f/2.8 lens:

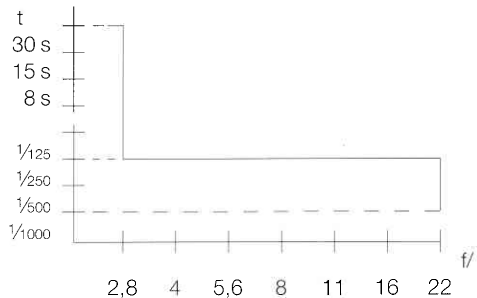

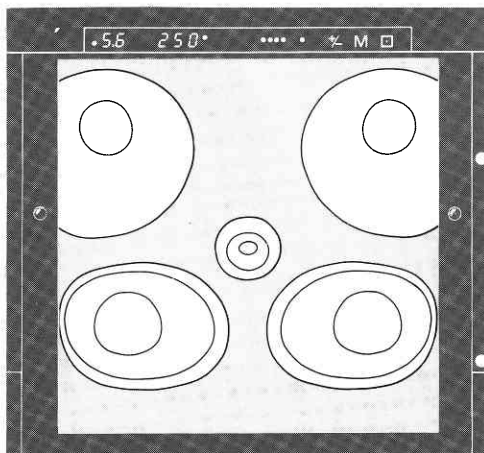
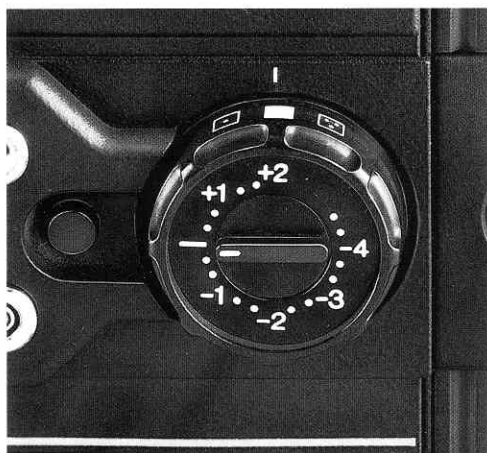

**Manual mode:** Select any combination of aperture and speed. The row of LED dots in the display strip 13 signals how close your combination is to a correct exposure – it is exactly right if only the green LED stays alight. (See also **Exposure readings** on page 17.)



### Selecting the metering mode

#### *Centre-weighted multi-zone readings:*

Seven silicon photodiodes mounted behind the semi-reflecting main mirror measure the light coming through the lens. The cell layout in five groups yields centre-weighted multi-zone readings suitable for most subjects. The cell layout also weights the foreground (lower part of the subject) against sky areas at the top. To select this meter mode turn the selector dial 47 to .

*Spot readings:* The central spot reading cell covers less than 1% of the image field and thus permits precise readings of small parts of high-contrast or back-lit subjects. As such parts rarely appear in the exact picture centre, you can aim at such a point, store the spot reading and then recompose the view. On the standard focusing screen the split-image circle also marks the spot reading area. Select this mode by turning the dial 47 to ; an LED (at the right of the finder display 13) also signals it.

*Multi-spot readings:* In this mode you separately read up to five subject points – highlights and shadows or else midtones – and store them. The camera's microprocessor then computes a mean value which you can store for a whole exposure sequence. Select this mode by turning the dial 47 to ; the finder displays the same LED as for spot readings. You record the readings with the meter key 30.

**Note:** If you switch on the camera in multi-spot mode, it immediately stores the first reading. To avoid such unwanted readings, switch to multi-spot mode *after* switching on the camera.

### Exposure readings

After selecting the exposure control and meter modes, switch on the meter by pushing the meter key 30 forward. The LEDs in the finder light up for about 20 sec; you can switch them on repeatedly with the key 30. They also stay on for 20 sec after releasing.

The LED display strip 13 in the finder shows the main functions and settings. At the left are the apertures and shutter speeds with  $\frac{1}{3}$  step interval signals. In manual mode a row of LEDs in the centre marks exposure deviations. The exposure is correct when only the green centre LED stays alight. Three red LEDs immediately to the left of the green LED signal progressive overexposure in  $\frac{1}{3}$  EV intervals up to 1 EV; a fourth red LED marks a -2 EV overexposure. LEDs to the right of the green one indicate corresponding underexposure levels. Further signals at the right: +/- = exposure correction, M = memory or AE lock in use,  = spot or multi-spot readings.

As mentioned, you can in multi-spot mode read up to five separate subject points, entered by pushing forward the meter/memory key 30. The finder LEDs indicate the computed mean values. After five such readings the  signal blinks to mark that the system accepts no further readings. You can store the computed mean for a series of exposures by pushing the memory key 30 backwards to engage. To clear the stored mean exposure; switch to centre-weighted multi-zone readings, or switch the camera off and on again.

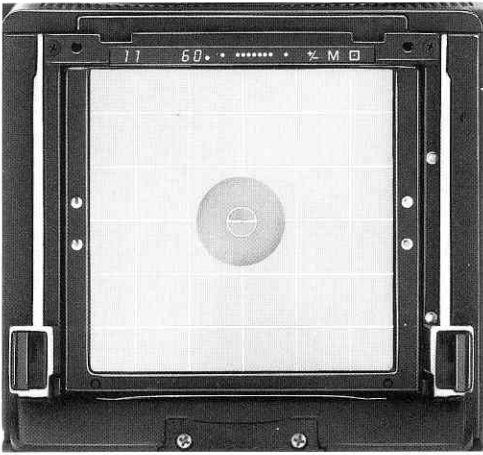

### More finder signals

If – in shutter speed-priority mode – the reading exceeds the aperture scale limits, the LED of the largest or the smallest aperture value will blink. So set a slower or faster shutter speed respectively. Similarly, in aperture-priority mode the slowest or fastest shutter speed blinks at the limits of the range (rarer, as the range is greater); in this case preset a larger or smaller aperture.

No correction is needed if the numbers blink while taking a reading in multi-spot mode; the camera correctly allows for exposure values past the scale limits, too. If the final mean value is outside the scale range, shift it into the range by correcting the aperture or speed as required.

A blinking shutter speed in programmed AE mode indicates that the subject needs a speed faster than  $\frac{1}{1000}$  sec – or, at the other extreme, longer than 30 sec.

The dots next to the aperture and speed values indicate intermediate steps. A dot at the bottom of a shutter speed is a next faster  $\frac{1}{3}$  step – e.g.  $125 \bullet =$  approx.  $\frac{1}{160}$  sec; a dot near the top of the value is  $\frac{1}{3}$  step slower ( $125 \bullet = \frac{1}{100}$  sec). Similarly a dot near the top of an f-value is  $\frac{1}{3}$  stop larger ( $\bullet 11 = f/10$  or  $f/8\frac{2}{3}$ ) while a bottom dot is  $\frac{1}{3}$  stop smaller ( $\bullet 11 = f/12.5$  or  $f/11\frac{1}{3}$ ).

A row of  $\square\square \square\square\square\square$  digits (other than momentarily when switching on) signifies that light conditions are beyond the camera's metering range. A series of dashes (– – – – –) appears if you have chosen an unusable mode or one that will produce wrong results. With PQ lenses this would appear:

- when you select automatic bracketing in manual mode;
- when you set B on the shutter speed dial in aperture-priority mode.

You can switch off all the above finder displays with the switch 34.

Near the top of the righthand screen edge a red LED 14 lights up when the battery capacity is good for only a few more exposures. (See **Battery check**, page 12.) Recharge the battery as soon as possible.

A further green LED 4 below that is a ready signal for dedicated flash units.

The switch 34 *does not* switch off the battery check or flash ready LEDs.

### **Depth of field preview**

To check depth of field press the stopdown key 35 and observe the extent of image sharpness on the screen through the magnifier 7. See also **Depth of field** on page 28.

### **Memory (AE lock)**

In difficult light conditions – for instance backlit or very contrasty subjects – take a spot reading of a significant image detail (preferably a midtone) and store the reading by engaging the memory (AE lock) key 30. Then recompose the picture and expose.

The reading remains stored until you release the key 30 (push forward). The key also serves to record individual readings in multi-spot mode. A red "M" lights up on the display strip 13 when the AE lock is engaged.

### **Stray light compensation**

The meter system allows for stray light coming through the open finder hood and compensates for stray light intensities up to about 16 times the measured light intensity. The compensation is operative all the time – when viewing through the prism finders, the magnifying hood or the folding hood with the magnifier swung up.

When you observe the screen at waist level without the magnifier, do not let direct light fall on the screen (sunlight, lamps, especially fluorescent tubes etc.).

Always keep the hood closed when making long time exposures.

**Note:** Stray light through the open hood may often exceed the compensation limits when taking meter readings with older type lenses. In that case keep the magnifier swung up during readings.

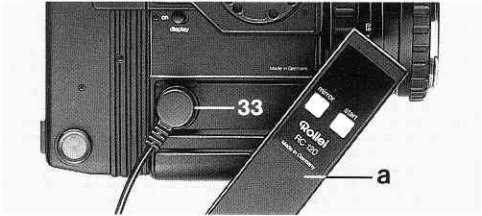
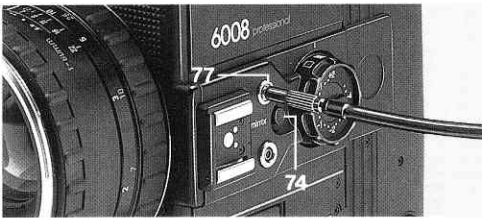

### Releasing the shutter and exposing

On the camera: Press either the release button 24 or the release key 28.

With a cable release: Screw a normal cable release into the socket 77.

With an accessory remote release **a**: Remove the cap from the remote outlet 33 and plug in the remote release. Press the "Start" button.

On releasing, the camera exposes the picture and immediately advances the film to the next frame.

### Prereleasing the mirror

To suppress every vestige of camera vibration, especially with long tele lenses or large closeups, establish the exposure and depress the button 74 ("mirror") to pre-release the mirror. Then press the release to take the picture. While the mirror is up in this way, the meter reading remains stored for about 4 min. So expose before this time is up – otherwise all stored values are cancelled. In that case – or if after all you don't want to make an exposure after prereleasing the mirror – turn the multi-exposure knob 48 to "ME", thus disengaging the film transport. Cover the lens with the lens cap and release the shutter. The mirror then returns without advancing the film and thus without wasting an exposure. Remember to turn the knob 48 back to "SE".

**Note:** Prerelease the mirror only if the battery has sufficient power reserve – for the camera draws current while the mirror is up.

### Multiple exposures

Turn the multi-exposure knob 48 to "ME" (multiple exposures). This disengages the film transport and you can now make a number of exposures, in succession, on the same film frame. A red rim below the knob 48 shows that it is set to multiple exposures.

*Before the last exposure* of a multi-exposure sequence turn the knob back to "SE" (single exposure) and push it in against the camera body. That way the film transport operates normally after that last exposure.

**Note:** Do not change magazines during a multi-exposure sequence.

### Continuous sequences

For continuous exposure sequences (successive exposures on successive frames – instead on the same frame as in multiple exposures) turn the main switch 1 past "S" (single exposures) to "C" (continuous). On pressing the release 24 or 28 the camera now keeps exposing and advancing the film as long as the release remains depressed. The maximum rate is about 2 pictures/sec. See also page 28.

### Automatic bracketing

The bracketing function is a special case of an exposure sequence. It automatically takes a correctly exposed shot plus two shots over and underexposed by  $+\frac{2}{3}$  and  $-\frac{2}{3}$  EV respectively.

Switch on the bracketing function by turning the main switch 1 to  $S\pm$  (bottom position). During releasing, keep the release depressed until the camera has made three exposures. You can shift the starting point of a bracketing sequence with the exposure correction dial 46 (see also page 27).



### Note the frame counter

The frame counter window 53 shows the No. of the next frame to be exposed. When you open the magazine back 38, the counter returns to "S" (start).

Other frame counter indications: "S" = no film or film not threaded; red arrow head = film not advanced to first frame; all-red window = backing paper trailer or film spooled up.

### Unloading

After the last exposure wait for the film transport to wind up the end of the backing paper. Then open the magazine back, lift out the film insert and remove and seal the full film spool. Replace the film insert (reloaded if required) and close the magazine back.

**Note:** Before opening the magazine back section 38, always push drawslide bar 51 all the way to "magazine change" (arrows). If this is not done, the drawslide can be damaged.

### Flash

The Rolleiflex 6008 SRC 1000 is X-synchronised for flash at all shutter speeds up to  $\frac{1}{500}$  sec (up to  $\frac{1}{1000}$  sec with PQS lenses). You set the aperture – determined by the flash guide No. and subject distance – *manually*.

If the flash unit has a foot contact, mount it directly in the hot shoe 76, thus switching on the latter's synch contact. The synch socket 75 takes standard 3 mm coaxial flash cable plugs. The two synch contacts are wired in parallel.

With dedicated flash units, linked through the Rollei SCA 356 adapter, the camera automatically controls the flash exposure. During the exposure a sensor inside the camera measures the light reflected from the film and – subject to the film speed setting – adjusts the flash duration accordingly. This thus ensures correctly exposed flash shots.

The film speed for such automatic flash exposure must be set on the film speed dial of the SCA 356 adapter; the ISO setting on the camera magazine is not relevant in this case.

The green flash ready light 4 in the finder signals that the flash unit is charged up ready for operation. It also indicates correct automatic exposure:

- If the green LED stays alight after releasing the camera and flash, the flash exposure was sufficient and the flash unit is immediately ready for the next shot.
- If the green LED blinks after releasing, the film received sufficient exposure. The flash unit is ready for the next shot as soon as the light of the green LED is steady. If the exposure used a lot of the flash power, the LED may go out between the blinking and steady phases.

- If the green LED neither lights nor blinks immediately after the flash, the available power of the flash was insufficient for a correct flash exposure. In that case try repeating the shot with a larger lens aperture.

## Interchangeable modules

The lens, finder, battery pack, film magazine and film insert are detachable from the Rolleiflex 6008. You would normally change the battery pack and film insert for recharging and reloading respectively. The other interchangeable modules provide alternative scope in viewing, controlling and recording the image.

### Changing film inserts

Push the drawslide bar 51 all the way to “magazine change” (arrows).

Open the magazine back 38, lift out the insert with the exposed and spooled up film, remove the film for processing. Drop in a loaded film insert, close the magazine back and press the shutter release to advance the new film to the first frame.

If you have only one film insert, reload this with a new film. Note that there is no need to switch spools: the insert is symmetrical and engages the transport gear either way round. Hence the empty feed spool of the last film can directly become the takeup spool for the next film.

If the new film differs in speed or type, change also the film box tab in the channel 58 and reset the film speed on the dial 40.

### Changing magazines

Push the drawslide bar 51 fully to the top to “magazine change”. Depress both magazine release keys 39 and 49 together. Swing away the magazine and lift out of its hinge. Hook in the alternative magazine at the hinge, then swing up and press home to engage. Fully push down the drawslide bar 51 (past the frame



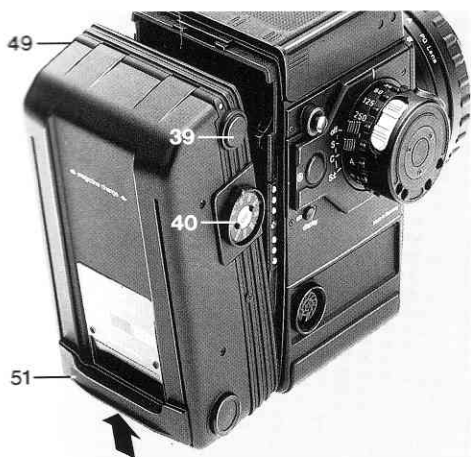

counter window 53). This opens the laminar drawslide and secures the magazine on the camera. It also unblocks the metering and exposure functions.

**There are six interchangeable magazine models, for the following film types and picture formats:**

**6×6/120 magazine for No. 120 film:**

**12 exposures 6×6 cm (2¼×2¼ in.)**

**4.5×6/120 magazine for No. 120 film:**

**16 exposures 4.5×6 cm (1¾×2¼ in.)**

**6×6/220 magazine for No. 220 film:**

**24 exposures 6×6 cm (2¼×2¼ in.)**

**4.5×6/220 magazine for No. 220 film:**

**32 exposures 4.5×6 cm (1¾×2¼ in.)**

**6×6/70 bulk film magazine for**

**perforated 70 mm film:**

**65–70 exposures 6×6 cm (2¼×2¼ in.)**

**Polaroid magazine for 6×6 cm (2¼×2¼ in.)**

**exposures on Polaroid film packs.**

**It is possible to fit the back of the Rolleiflex 6002 or SLX on the Rolleiflex 6008; however this combination may not keep the film properly flat and you risk unsharp pictures. On the other hand, never fit a magazine of the 6008 on a Rolleiflex 6002 or SLX body – this causes mechanical damage.**

### Identifying the magazines

The recess 50 takes 12–13 mm (½ in.) self-adhesive spots available from stationers. Use them – possibly in different colours – to mark the magazine number, film type or subject.

Colour coded lettering surrounding the frame counter window also marks the different magazine types.

### Using 6006 magazines

You can use film magazines of the Rolleiflex 6006 on the Rolleiflex 6008. But as the 6006 magazines have no electric film speed input to the camera, the 6008's exposure system assumes a default speed of ISO 100. For films of different speed adjust the exposure correction dial 46 accordingly. In effect this can cope with film speeds from ISO 25 (+2 EV correction setting) to ISO 2500 (–4⅔).

The universal 6000 magazines function on the Rolleiflex 6006 like 6006 magazines – i.e. without direct film speed input. You then set the film speed on the 6006 camera in the usual way. On request, we can upgrade 6006 magazines to the universal 6000 type via the Rollei Service.

Main magazine differences: Rear labelling on current 6000 magazines starts "Rollei Magazin 6000 . . ."; the film speed dial carries only red ISO settings and the drawslide bar 51 has two horizontal ribs. Rear labelling on older 6006 models starts "Rolleiflex 6006 Magazin . . ."; the film speed dial carries yellow ASA (25 to 6400) and white DIN values (15 to 39). The drawslide bar is smooth.

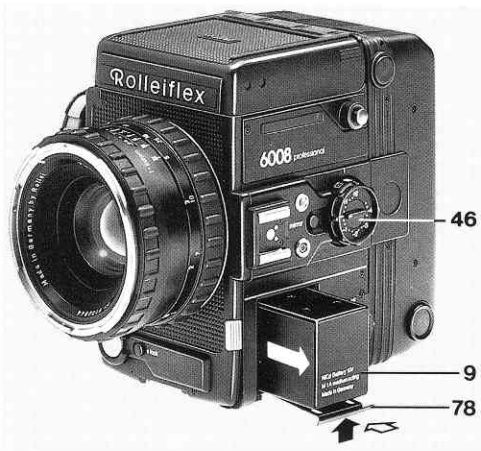

### Changing the battery pack

Press the grip bar 78 upwards and use it to pull out the spent battery pack. Hold the new battery pack 9 with grip bar towards the camera base and push fully into the battery compartment. Push in the grip bar to engage.

At normal room temperature – around 20° C or 65 – 70° F – a full charge of the battery pack is good for about 500 exposures. That is about 40 No. 120 rollfilms of 6×6 cm exposures – or 20 No. 220 films.

Where you cannot afford to interrupt shooting sessions or if you have to shoot in very cold weather, it is more convenient to have two battery packs: Keep one in the camera and the second as reserve while the first is being recharged.

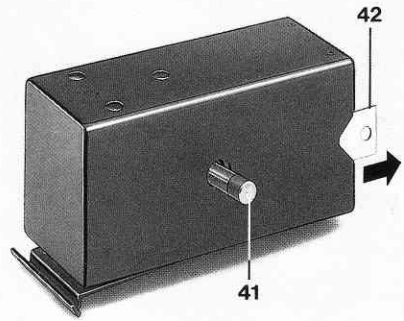

### Changing the fuse

Remove the battery pack and pull out the fuse 10. Withdraw the panel 42 to release the spare fuse 41. Push this fully home into the fuse clips. Close the panel 42. Get a new spare fuse as soon as possible (20 mm cartridge, 250 volts, 1 amp, medium-slow); obtainable from radio, electrical or photo stores.

**To avoid the risk of damage to the camera, never fit a fuse other than the type specified.**

If the spare fuse blows, too, look for cause that could put extra strain on the motor, e.g. wrongly loaded film (especially if not spooled straight), film torn in very cold weather, film detached from backing paper. If no cause is apparent, check with Rollei Fototechnic Servicing.



### Lens changing

Press in the lens release catch 73, turn the lens anticlockwise and remove. To fit an alternative lens, align its rear red mark with the red dot inside the camera mount, insert the lens and turn clockwise to engage.

After changing lenses take a new exposure reading – the new view may differ in brightness distribution.

Interchangeable lenses cover focal lengths from 30 to 1000 mm. Data sheets included with the lenses provide depth of field, technical and closeup data for use with extension tubes and the bellows.

### Using older lenses (SLX, 6002, 6006)

When using earlier (non-PQ) lenses which have no built-in aperture simulator, you have to press the meter key 30 or the stopdown key 35 to display a working-aperture exposure reading.

**Note:** Pressing the meter key 30 also stores the reading. After any adjustment of the aperture or speed therefore repeat the reading by pressing the meter key afresh.

In manual or aperture priority mode, the reading on pressing the stopdown key allows for exposure corrections set.

On releasing, the camera exposes at the aperture/speed combination measured, even when you used the stopdown key. Compared with PQ lenses, the working-aperture metering of older lenses reduces the metering range (EV 5–19 instead of EV 3–19).

### Finder signals with older lenses

Lacking an aperture simulator, such lenses do not show the aperture in the LED display. As noted above, you read that from the lens's aperture pointer, after pressing the meter key 30 or the stopdown key 35. In shutter speed priority mode, if the upper or lower intermediate-aperture dot blinks, you have exceeded the limits of the available aperture range. So preset a different shutter speed.

All other signals are the same as with PQ lenses (see page 18).

The following operating modes do not work with older lenses. The LED display shows --- instead of aperture and shutter speed values:

- Shutter speed priority with B setting
- Automatic bracketing
- Multi-spot readings.



73

### Lens changing

Press in the lens release catch 73, turn the lens anticlockwise and remove. To fit an alternative lens, align its rear red mark with the red dot inside the camera mount, insert the lens and turn clockwise to engage.

After changing lenses take a new exposure reading – the new view may differ in brightness distribution.

Interchangeable lenses cover focal lengths from 30 to 1000 mm. Data sheets included with the lenses provide depth of field, technical and closeup data for use with extension tubes and the bellows.

### Using older lenses (SLX, 6002, 6006)

When using earlier (non-PQ) lenses which have no built-in aperture simulator, you have to press the meter key 30 or the stopdown key 35 to display a working-aperture exposure reading.

**Note:** Pressing the meter key 30 also stores the reading. After any adjustment of the aperture or speed therefore repeat the reading by pressing the meter key afresh.

In manual or aperture priority mode, the reading on pressing the stopdown key allows for exposure corrections set.

On releasing, the camera exposes at the aperture/speed combination measured, even when you used the stopdown key. Compared with PQ lenses, the working-aperture metering of older lenses reduces the metering range (EV 5–19 instead of EV 3–19).

### Finder signals with older lenses

Lacking an aperture simulator, such lenses do not show the aperture in the LED display. As noted above, you read that from the lens's aperture pointer, after pressing the meter key 30 or the stopdown key 35. In shutter speed priority mode, if the upper or lower intermediate-aperture dot blinks, you have exceeded the limits of the available aperture range. So preset a different shutter speed.

All other signals are the same as with PQ lenses (see page 18).

The following operating modes do not work with older lenses. The LED display shows --- ---- instead of aperture and shutter speed values:

- Shutter speed priority with B setting
- Automatic bracketing
- Multi-spot readings.

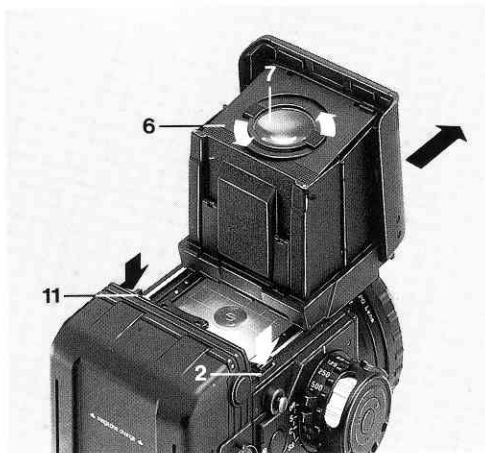

### Changing the finder

Open the standard hood, press down both release catches 2 and 11 together and pull the hood off towards the front. In the same way slide on the alternative finder horizontally towards the back, but without pressing the release catches. The catches engage on their own.

When you fit 45° or 90° prism finders, the latter automatically switch the LED strip 13 to a right-reading display.

### Changing magnifiers for spectacle wearers

The magnifier 7 in the folding hood is interchangeable. For viewing without spectacles you can order (from Rollei) alternative magnifiers. These range from +2.5 to -4.5 diopters, to match your prescription for distance viewing glasses.

To change the magnifier, hold the sides of the magnifier panel 6 between the thumb and index finger, pressing the side flaps of the hood against the panel. With the other hand turn the magnifier anticlockwise by its lugs and lift out. Drop in the alternative magnifier and turn clockwise to secure.

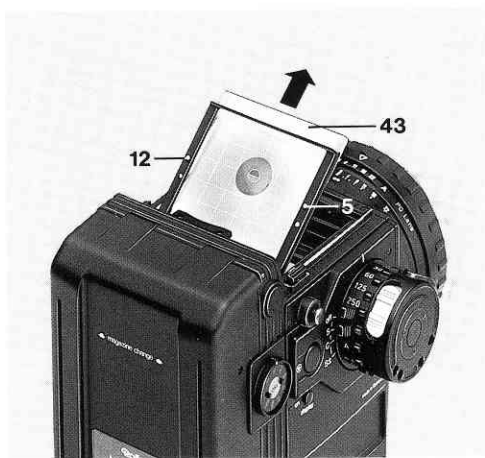

### Changing the focusing screen

Remove the folding hood (or other finder in use), pull both screen frame lugs 5 and 12 backwards and raise up the screen frame. Carefully withdraw the screen 43 from the guides. Hold it by the edges only – never touch the surfaces – and store wrapped up dust-free. Push in the alternative screen – with the matt side facing the mirror – between the springs and guides. Swing down the frame, pull slightly backwards and fully push down to engage at both sides.