

Panasonic

Voice Processing System Installation Manual

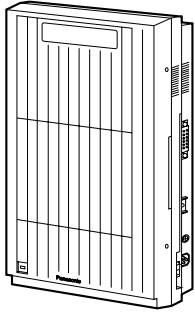

Model **KX-TVS125**
KX-TVS225/KX-TVS325



Thank you for purchasing the Panasonic Model KX-TVS125/KX-TVS225/KX-TVS325 Voice Processing System. Please read this manual carefully before using this product and save this manual for future use.

Thank you for purchasing the Panasonic Model KX-TVS125/
KX-TVS225/KX-TVS325 Voice Processing System.

We are confident that it will provide your customer or client with many years of dependable service.

This Voice Processing System was especially tailored for the American environment. For example, it can be configured for English, a second language, or a third language:

System prompts—Recorded at the factory in English

User 1 prompts—Record in any language you like

User 2 prompts—Recorded at the factory in Spanish

These prompts guide subscribers and non-subscribers through specific VPS operations.

In addition, the VPS supports many other languages through the use of **Custom Service** menus. These can be used to greet outside callers who merely need to be guided to a destination (such as an extension, a mailbox, or a fax machine). Many languages can be supported as there are 12 keys on a touchtone phone and you can record up to 100 Custom Service menus. One twelfth of these menus can be recorded in one language if you desire. Another twelfth can be recorded in another language, and so on. Thus callers can be guided entirely in their native languages. For a multi-cultural United States, Custom Service is a truly powerful feature. Please see "Custom Service" in Appendix A1 SYSTEM FEATURES for more details.

Note

This product is only for connection behind a suitable PBX and should not be connected directly to the network.

Panasonic World Wide Web Address: <http://www.panasonic.com>
for customers in the United States or Puerto Rico.

List of Enhancements

Compared to the KX-TVS120/KX-TVS220/KX-TVS320 Voice Processing System, these models are enhanced by the following new features:

- **Personal Custom Service**

Allows a subscriber to set the following Custom Services in his personal greeting (Personal Custom Service):

- Transfer to Mailbox
- Transfer to Extension
- Transfer to Outside
- Custom Service
- VM Service (Voice Mail Service)
- AA Service (Call Transfer Service)

A caller can select a desired service from those above while listening to the personal greeting or recording a message. (See page 262.)

- **Subscriber Tutorial**

When a subscriber accesses his mailbox for the first time, the VPS guides him to set up the mailbox with some Help messages. Simply by following the messages, he can set up these items:

- Password
- Owner's Name
- Personal Greetings (No Answer Greeting/Busy Greeting/After Hours Greeting)

(See page 267.)

- **Call Transfer to Outside**

Enables the VPS to transfer a call to an outside line from the following services:

- Custom Service
- Call Transfer Service
- Personal Custom Service
- Caller ID Callback

(See page 247.)

- **DID Call Routing**

As well as Caller ID Call Routing, up to 200 DID numbers can be assigned to be automatically forwarded to a desired destination. The VPS automatically forwards calls from the assigned DID numbers to a programmed extension, mailbox (including System Group Distribution List) or Custom Service. (See page 249.)

- **Toll Saver**

Allows a subscriber to check his mailbox from a pre-assigned DID/Caller ID number without necessarily making the VPS answer the call. Without Toll Saver, the VPS will always answer the call and therefore he will incur toll charges. With Toll Saver, the VPS can let him know that there are no new messages without answering his call. (See page 318.)

- **Improvement of System Security**

By default, the System/Message Managers cannot access the VPS from their telephones until the System Administrator enables the relevant settings and sets a password for access. The System/Message Managers always need to enter this

password to access the VPS. (See page 332.)

The System Administrator can also choose to set a default password for subscribers' mailboxes. If this setting is enabled, a default password is automatically assigned when mailboxes are created (See page 333.)

- **Additional PBX Connectivity**

Allows the VPS to be connected to a KX-TDA/KX-TAW series PBX to enable new features such as One-Touch Two-Way Transfer. (See page 347.)

- **New Utility Commands**

The following utility commands have been added:

- **TURN** (See page 220.)
This allows you to easily turn off and turn on System and User prompts.
- **PREP** (See page 221.)
This allows you to visualize Personal Custom Service menus.

Important Information

SAFETY REQUIREMENTS

- Follow all product warnings, cautions, and instructions.
- Handle the unit carefully. Do not drop or otherwise expose the unit to physical shock.
- If the unit malfunctions, disconnect the unit from the telephone line and check the line by reconnecting the telephone. If the telephone operates properly, have the VPS repaired by a qualified Panasonic Factory Service Technician.
- Install the unit so that the power cord is not obstructed in any way. Do not connect this unit to an extension cord.
- Keep the unit free of dust, moisture, condensation, high temperature exposure (more than 40 °C {104 °F}) and vibration. Do not expose the unit to direct sunlight.
- Mount the unit on a stable wall surface. Do not mount the VPS inside of a separate enclosure unless it is properly ventilated.
- Read all the information contained in this manual.
- This unit is designed to operate at one specific voltage and current setting. The proper voltage and current required for this unit are listed on the product label.
- This unit is equipped with a 3-wire grounding plug. The plug will only fit into a grounded power outlet. Do not modify this plug in any way. If it cannot be inserted into the outlet, have the outlet replaced by a licensed electrician.
- Unplug and transport the unit to a service technician if the power supply cord is frayed or damaged, if the cabinet is cracked or broken, or when the unit has been exposed to moisture, has been dropped, or is not otherwise operating properly.
- Unplug the unit from its power source before cleaning.
- Do not block the vent slots and openings located on all sides of the unit.
- Do not disassemble this product. Dangerous electrical shock could result. The unit must only be disassembled and repaired by qualified Panasonic Factory Service Technicians.
- Do not insert wires, pins, or any other material into the unit's vent slots or access points. This could result in electrical shock and serious unit malfunction.
- Do not install the unit near water or moisture, heating appliances, or electrical noise generating devices such as televisions, monitors, fluorescent lamps, or electric motors.
- Do not overload wall outlets. Overloaded outlets could result in fire and/or electrical shock.
- Do not use solvents, liquid cleaners, water, or abrasive powders to clean this unit. Use only a damp soft cloth for cleaning.
- Do not use the telephone during a lightning storm or to report a gas leak in the vicinity of the leak.

WARNING

TO PREVENT THE RISK OF FIRE OR ELECTRIC SHOCK, DO NOT EXPOSE THIS PRODUCT TO RAIN OR MOISTURE.

When you ship the product

Carefully pack and send it prepaid, adequately insured and preferably in the original carton. Attach a postage-paid letter, detailing the symptom, to the outside of the carton. DO NOT send the product to the Executive or Regional Sales offices. They are NOT equipped to make repairs.

Product service

Panasonic Factory Servicenters for this product are listed in the servicenter directory. Consult your certified Panasonic dealer for detailed instructions.

The serial number of this product may be found on the label affixed to the bottom of the unit. You should note the serial number of this unit in the space provided and retain this book as a permanent record of your purchase to aid in identification in the event of theft.

MODEL NO.: _____

SERIAL NO.: _____

For your future reference

DATE OF PURCHASE _____

NAME OF DEALER _____

DEALER'S ADDRESS _____

DEALER'S TEL. NO. _____

WARNING

THIS UNIT MAY ONLY BE INSTALLED AND SERVICED BY QUALIFIED SERVICE PERSONNEL.

WHEN A FAILURE OCCURS WHICH EXPOSES ANY INTERNAL PARTS, DISCONNECT THE POWER SUPPLY CORD IMMEDIATELY AND RETURN THIS UNIT TO YOUR DEALER.

DISCONNECT THE TELECOM CONNECTION BEFORE DISCONNECTING THE POWER CONNECTION PRIOR TO RELOCATING THE EQUIPMENT, AND RECONNECT THE POWER FIRST.

THIS UNIT IS EQUIPPED WITH A GROUNDING CONTACT PLUG. FOR SAFETY REASONS, THIS PLUG MUST ONLY BE CONNECTED TO A GROUNDING CONTACT SOCKET WHICH HAS BEEN INSTALLED ACCORDING TO REGULATIONS.

CAUTION

Danger of explosion if battery is incorrectly replaced.

**Replace only with the same or equivalent type recommended by the manufacturer.
Dispose of used batteries according to the manufacturer's instructions.**

Note

Before you start setting or changing system parameters, we recommend that you turn off the Call Progression Mode with the OFLN command. While off, the power LED of the VPS will flash and the VPS will not answer any incoming call. After you finish programming, use the ONLN command to turn on the Call Progression Mode (normal operation). Please see 7.2.1 Off-line Set (OFLN) and 7.2.2 On-line Set (ONLN) for more details.

Trademarks

- HyperTerminal is either a registered trademark or a trademark of HILGRAEVE, INCORPORATED in the United States and/or other countries.
- IBM is a registered trademark of International Business Machines Corporation in the United States.
- Procomm Plus is either a registered trademark or a trademark of DATASTORM TECHNOLOGIES, INC. in the United States and/or other countries.
- Smartcom is either a registered trademark or a trademark of Hayes Microcomputer Products, Inc. in the United States and/or other countries.
- All other trademarks identified herein are the property of their respective owners.
- Screen shots reprinted with permission from Microsoft Corporation.

F.C.C. REQUIREMENTS AND RELEVANT INFORMATION

Notify The Telephone Company

This equipment complies with Part 68 of the FCC rules and the requirements adopted by the ACTA. On the bottom of this equipment is a label that contains, among other information, a product identifier in the following format:

- US:ACJVM04BKX-TVS220 (KX-TVS125/KX-TVS225)
- US:ACJVM04BKX-TVS320 (KX-TVS325)

If requested, this number must be provided to the telephone company.

Installation must be performed by a qualified professional installer. If required, provide the telephone company with the following technical information:

- The telephone numbers to which the system will be connected
- Make: Panasonic
- Model: KX-TVS125/KX-TVS225/KX-TVS325
- Ringer Equivalence No.: 0.4B
- Facility Interface Code: 02LS2
- Service Order Code: 9.0F
- Required Network Interface Jack: RJ11C

Ringer Equivalence No. (REN)

The REN is used to determine the number of devices that may be connected to a telephone line. Excessive RENs on a telephone line may result in the devices not ringing in response to an incoming call. In most but not all areas, the sum of RENs should not exceed five (5.0). To be certain of the number of devices that may be connected to a line, as determined by the total RENs, contact the local telephone company. For products approved after July 23, 2001, the REN for this product is part of the product identifier that has the following format:

- US:ACJVM04BKX-TVS220 (KX-TVS125/KX-TVS225)
- US:ACJVM04BKX-TVS320 (KX-TVS325)

The digits represented by 04 are the REN without a decimal point (e.g., 03 is a REN of 0.3).

Telephone Service Problems

If this equipment causes harm to the telephone network, the telephone company will notify you in advance that temporary discontinuance of service may be required. But if advance notice isn't practical, the telephone company will notify the customer as soon as possible. Also, you will be advised of your right to file a complaint with the FCC if you believe it is necessary.

Changes in Telephone Company Communications Facilities, Equipment, Operations, and Procedures

The telephone company may make changes in its facilities, equipment, operations or procedures that could affect the operation of the equipment. If this happens the telephone company will provide advance notice in order for you to make necessary modifications to maintain uninterrupted service.

Trouble with this equipment

If trouble is experienced with this equipment, for repair or warranty information, please contact a Factory Servicenter or other Authorized Servicer. If the equipment is causing harm to the telephone network, the telephone company may request that you disconnect the equipment until the problem is resolved.

Connection to the Party Line

Connection to party line service is subject to state tariffs. Contact the state public utility commission, public service commission or corporation commission for information.

Combined Use with Alarm Equipment

If your home has specially wired alarm equipment connected to the telephone line, ensure the installation of this equipment does not disable your alarm equipment. If you have questions about what will disable alarm equipment, consult your telephone company or a qualified installer.

Note

This equipment has been tested and found to comply with the limits for a Class A digital device, pursuant to Part 15 of the FCC Rules. These limits are designed to provide reasonable protection against harmful interference when the equipment is operated in a commercial environment. This equipment generates, uses, and can radiate radio frequency energy and, if not installed and used in accordance with the instruction manual, may cause harmful interference to radio communications. Operation of this equipment in a residential area is likely to cause harmful interference in which case the user will be required to correct the interference at his own expense.

CAUTION

Any changes or modifications not expressly approved by the party responsible for compliance could void the user's authority to operate this device.

Table of Contents

1	VOICE PROCESSING SYSTEM OVERVIEW	17
1.1	WHAT THE VPS CAN AND CANNOT DO	18
1.1.1	Why Voice Processing?	18
1.1.2	Basic Operations	18
1.1.3	VPS Limitations	19
1.2	SYSTEM ADMINISTRATION, MANAGEMENT, AND USE	20
1.2.1	System Administration	20
1.2.2	System Management	20
1.2.3	Subscriber Use	20
1.3	SYSTEM BASICS	21
1.3.1	General	21
1.3.2	System Components	21
1.3.3	Which Phone Systems are Compatible?	27
1.3.4	Installer Equipment and Software Requirements	28
1.3.5	Specifications	28
1.3.6	Hardware	29
1.3.7	Expansion Capabilities	29
1.3.8	Internal Modem Card (KX-TVS325 only)	29
1.3.9	Recommendations for System Configuration	30
1.4	VOICE MAIL INTEGRATION	32
1.4.1	General	32
1.4.2	Connection Examples—KX-TVS125	33
1.4.3	Connection Examples—KX-TVS225	35
1.4.4	Connection Examples—KX-TVS325	37
2	INSTALLATION	41
2.1	SAFETY PRECAUTIONS	42
2.1.1	Installation	42
2.1.2	Wiring	43
2.1.3	Environmental Requirements	44
2.2	UNPACKING	45
2.3	MOUNTING THE VPS ON THE WALL	46
2.4	FRAME GROUND CONNECTION	48
2.5	INSTALLATION STEPS	49
2.6	INSTALLING PORT EXPANSION CARDS: KX-TVS102 OR KX-TVS204	51
2.6.1	General	51
2.6.2	Installing the KX-TVS102 or KX-TVS204 Port Card	52
2.7	CONNECTIONS	55
2.7.1	Connecting to the PBX	55
2.7.2	Opening the Ferrite Core and Cable Clip	55
2.7.3	Modular Plug Connection	56
2.7.4	Port Cards	56
2.7.5	Internal Modem Card (KX-TVS325 only)	59
2.8	TERMINAL CONNECTION	60
2.8.1	Requirements for Connecting Programming Terminal	60
2.8.2	Connecting the RS-232C Cable	60
2.8.3	RS-232C Signals	61

3	INTEGRATING THE VPS WITH PANASONIC KX-T PHONE SYSTEMS	63
3.1	GUIDELINES FOR INTEGRATION.....	64
3.1.1	DPT or Inband Signaling?	64
3.1.2	Why Integration is Important	64
3.1.3	How the VPS and the PBX Communicate	64
3.1.4	PBX Requirements for Integration	65
3.2	PBX PARAMETERS AND PORT SETTINGS.....	67
3.2.1	General Guidelines and Definitions.....	67
3.2.2	RS-232C Settings	67
3.2.3	Port Settings.....	67
3.2.4	PBX Interface Parameters	68
3.3	CONNECTING THE VPS WITH PANASONIC KX-T SERIES PBXs.....	72
3.3.1	VPS Programming for Inband Integration	72
3.3.2	KX-TA624 Programming for Inband Integration via the Manager's Extension.....	73
3.3.3	KX-TD500 Programming for Inband Integration.....	75
3.3.4	KX-TD816, KX-TD1232, KX-TA1232 and KX-TD308 Programming for Inband Integration via the Manager's Extension.....	84
3.3.5	KX-TD816, KX-TD1232, and KX-TA1232 Programming for Inband Integration via the Operating and Maintenance Tool.....	85
3.3.6	KX-TD308 Programming for Inband Integration via the Operating and Maintenance Tool	88
3.3.7	KX-TDA/KX-TAW series Programming for Inband Integration.....	92
4	INTEGRATING THE VPS WITH THE PANASONIC KX-T DIGITAL PBX	101
4.1	GUIDELINES FOR DPT INTEGRATION.....	102
4.1.1	Why DPT Integration is Important.....	102
4.2	KX-TD500 PROGRAMMING FOR DIGITAL INTEGRATION	104
4.3	KX-TDA/KX-TAW SERIES PROGRAMMING FOR DIGITAL INTEGRATION	114
4.4	CONNECTING THE VPS WITH THE PANASONIC KX-TD816, KX-TD1232, KX-TA1232 AND KX-TD308	119
4.4.1	KX-TD1232 Software Verification and Programming for DPT Integration via the Manager's Extension.....	119
4.4.2	KX-TD1232 Software Verification and Programming for DPT Integration via the Operating and Maintenance Tool	125
4.4.3	KX-TD308 Software Verification and Programming for DPT Integration via the Manager's Extension	128
4.5	DPT INTEGRATION FEATURES AND SETUP PROCEDURES FOR THE PANASONIC KX-TA1232 AND KX-TD SERIES.....	133
4.5.1	Live Call Screening (LCS) Programming	133
4.5.2	Live Call Screening Password Assignment.....	133
4.5.3	Live Call Screening Password Canceling	134
4.5.4	Live Call Screening Recording Mode Assignment via System Programming.....	134
4.5.5	Live Call Screening Private/Hands-Free Mode Assignment via Station Programming.....	135
4.5.6	Live Call Screening Assignment via PC Programming	136
4.5.7	Live Call Screening Button Assignment via Station Programming.....	137
4.5.8	Live Call Screening Cancel Button Assignment via Station Programming	137
4.5.9	Two-Way Recording Button Assignment via Station Programming	138
4.5.10	Two-Way Transfer Button Assignment via Station Programming	139

4.5.11	Voice Mail Transfer Button Assignment via Station Programming	139
4.5.12	Button Assignment via PC Programming	140
4.5.13	Live Call Screening Activation	142
4.5.14	Live Call Screening Password Control	142
4.5.15	Two-Way Recording into Mailbox	142
4.5.16	Two-Way Transfer into Mailbox	142
4.5.17	A Restriction on TWR/TWT Activation	143
4.6	DPT INTEGRATION FEATURES AND SETUP PROCEDURES FOR THE PANASONIC KX-TDA/KX-TAW SERIES PBX	144
4.6.1	Live Call Screening (LCS) Programming	144
4.6.2	Live Call Screening Password Assignment	144
4.6.3	Live Call Screening Password Canceling	145
4.6.4	Live Call Screening Recording Mode Assignment	145
4.6.5	Live Call Screening Private/Hands-Free Mode Assignment	146
4.6.6	Live Call Screening Assignment via PC Programming	147
4.6.7	Live Call Screening Button Assignment	148
4.6.8	Two-Way Recording (TWR) Button Assignment	149
4.6.9	Two-Way Transfer (TWT) Button Assignment	149
4.6.10	One-Touch Two-Way Transfer (One-Touch TWT) Button Assignment	151
4.6.11	Voice Mail Transfer (VTR) Button Assignment	152
4.6.12	Button Assignment via PC Programming	152
4.6.13	Live Call Screening Activation	153
4.6.14	Two-Way Recording (TWR) into Mailbox	154
4.6.15	Two-Way Transfer (TWT) into Mailbox	154
4.6.16	One-Touch Two-Way Transfer (One-Touch TWT) into Mailbox	154
4.6.17	Voice Mail Transfer (VTR) Programming	154
5	CUSTOMIZING THE SYSTEM	155
5.1	STARTING UP	156
5.1.1	Before Programming	156
5.1.2	Quick Setup	156
5.1.3	Starting the Quick Setup	157
5.2	PORT SETTING OPTIONS	165
5.2.1	Custom Service Setting Example	165
5.2.2	Custom Service Features	166
5.2.3	Custom Service Programming	168
5.2.4	Recording Menus	171
5.2.5	Checking Operation	171
5.2.6	Voice Mail	171
5.2.7	Mailbox Groups	172
5.2.8	Extension Groups	172
5.2.9	Interview Service	173
5.2.10	Automated Attendant	174
5.2.11	Department Dialing Service	174
5.2.12	Operator Service	174
5.3	SETTING PORTS	175
5.3.1	Port Service Menu	175
5.4	AUTOMATED ATTENDANT PARAMETERS	177
5.4.1	Automated Attendant Menu	177
5.4.2	Department Dialing	177
5.4.3	Operator's Parameters	178

5.5	SETTING MAILBOXES	181
5.5.1	Mailbox Setting Menu.....	181
5.5.2	Entering a Mailbox	181
5.5.3	Deleting a Mailbox.....	187
5.5.4	Password Reset.....	187
5.5.5	Mailbox Listing	188
5.6	TRAINING THE SUBSCRIBER.....	189
6	FINAL SETUP	191
6.1	MESSAGE MANAGER'S MAILBOX (Mailbox 9998).....	192
6.1.1	Accessing the Message Manager's Mailbox.....	192
6.1.2	Main Menu of Message Manager's Service	192
6.1.3	Company Greetings (Enter #6*9998,5,1).....	193
6.1.4	Custom Service Greetings (Enter #6*9998,5,4).....	193
6.1.5	Customizing User Prompts (Enter #6*9998,5,6).....	193
6.2	SETTING UP MAILBOXES	195
6.2.1	Subscriber Tutorial.....	195
6.2.2	Changing Password, Owner's Name, and Personal Greetings	197
6.3	BACKING UP THE SYSTEM	198
7	SYSTEM MAINTENANCE AND TROUBLESHOOTING.....	201
7.1	INITIALIZING THE SYSTEM	202
7.2	UTILITY COMMANDS	204
7.2.1	Off-line Set (OFLN)	205
7.2.2	On-line Set (ONLN).....	205
7.2.3	Set Password (PASS).....	205
7.2.4	Set Time (TIME).....	206
7.2.5	Print Reports at Specified Time (PSET).....	207
7.2.6	Error Log Display (ELOG)	208
7.2.7	Saving the System Data to the Backup Device (SAVE).....	210
7.2.8	Loading New or Saved Data to the VPS (LOAD).....	212
7.2.9	Print All of the VPS Parameters (GPRN)	213
7.2.10	Program Version Display (VERS)	213
7.2.11	Custom Service Report (CREP).....	214
7.2.12	Custom Service Menu Access Count Clear (CCLR).....	215
7.2.13	Message Waiting Lamp Retry Times (MWL)	215
7.2.14	Setting Minimum Recording Length (MRL).....	215
7.2.15	Modified Prompt List (MPLT)	216
7.2.16	Utility Command List (HELP)	217
7.2.17	Quick Setup (QSET)	217
7.2.18	Circuit Condition Display (LMON)	218
7.2.19	Touchtone Information Display (PUTD)	218
7.2.20	Wait for Caller ID (WCID).....	220
7.2.21	Turn off System/User Prompt (TURN)	220
7.2.22	Personal Custom Service Assignment (PREP).....	221
7.3	SYSTEM REPORTS	222
7.3.1	Mailbox Assignments	223
7.3.2	COS (Class of Service) Assignments	223
7.3.3	System Service Report	225
7.3.4	Call Account Report	226
7.3.5	Call Account Report Clear.....	227

7.3.6	Port Usage Report.....	227
7.3.7	Port Usage Statistics Clear.....	228
7.3.8	Disk Usage Report	229
7.3.9	Disk Usage Statistics Clear	230
7.3.10	Mailbox Usage Report.....	230
7.3.11	Mailbox Usage Statistics Clear.....	231
7.3.12	Fax Call Report.....	232
7.3.13	Fax Call Statistics Clear	232
7.4	REMOTE PROGRAMMING (KX-TVS325 Only)	233
7.5	TROUBLESHOOTING GUIDE.....	235
7.6	SPECIFICATIONS	238
A	SYSTEM FEATURES	241
A1	SYSTEM FEATURES	242
B	SYSTEM ADMINISTRATOR'S GUIDE.....	273
B1	SYSTEM NAVIGATION	274
B2	SYSTEM ADMINISTRATION—MAILBOXES.....	278
B3	SYSTEM ADMINISTRATION—SETTING COS (CLASS OF SERVICE) PARAMETERS	285
B4	SYSTEM ADMINISTRATION—PORT/TRUNK SERVICE.....	299
B4.1	Port Assignment.....	299
B4.2	Trunk Group Assignment.....	301
B5	SYSTEM ADMINISTRATION—SERVICE SETTINGS	304
B5.1	Automated Attendant Parameters	304
B5.2	Custom Service	311
B5.3	Intelligent Call Handling.....	314
B5.4	Toll Saver	318
B6	SYSTEM ADMINISTRATION—SYSTEM PARAMETER SETTINGS	319
B6.1	System Group Assignment.....	319
B6.2	Time Group Service.....	322
B6.3	Holiday Setting	326
B6.4	Daylight Saving Time (DST)	328
B6.5	Prompt Setting.....	329
B6.6	System Caller Name Announcement	331
B6.7	System Security.....	332
B6.8	Other Parameters	334
B7	SYSTEM ADMINISTRATION—HARDWARE SETTINGS.....	345
B7.1	RS-232C Parameters	345
B7.2	Port Setting.....	346
B7.3	PBX Interface Parameters.....	347
C	SYSTEM MANAGER'S GUIDE	359
C1	ACCESSING THE SYSTEM MANAGER'S MAILBOX.....	360
C2	SETTING UP MAILBOXES.....	362
C3	SETTING COS (CLASS OF SERVICE) PARAMETERS.....	365
C4	SETTING THE SYSTEM CLOCK	372
C5	CHANGING THE SERVICE MODE SETTING.....	374
C6	CHANGING THE COMPANY GREETING AND INCOMING CALL SERVICE SETTING	376
C7	INITIALIZING THE INTERNAL MODEM (KX-TVS325 Only).....	378

C8	CHECKING SYSTEM USAGE (SYSTEM REPORTS).....	379
C9	DELIVERING MESSAGES.....	381
C10	CUSTOMIZING THE SYSTEM MANAGER'S MAILBOX	384
C11	LISTENING TO SYSTEM MANAGER MESSAGES	385
D	MESSAGE MANAGER'S GUIDE	387
D1	ACCESSING THE MESSAGE MANAGER'S MAILBOX.....	388
D2	MANAGING THE GENERAL DELIVERY MAILBOX.....	389
D3	SETTING UP MESSAGE WAITING NOTIFICATION	391
D4	CUSTOMIZING THE MESSAGE MANAGER'S MAILBOX	394
D5	SETTING THE SYSTEM CLOCK.....	396
D6	RECORDING MESSAGES.....	398
D7	REMOTE CALL FORWARDING SET	403
D8	LIST OF PROMPTS FOR VOICE MAIL AND AA SERVICE	405
D9	LIST OF MODIFIABLE PROMPTS	407
	Glossary	461
	Index	473



Section 1

VOICE PROCESSING SYSTEM OVERVIEW

1.1 WHAT THE VPS CAN AND CANNOT DO

1.1.1 Why Voice Processing?

The VPS handles incoming and outgoing calls. When a call comes in, it answers, forwards to appropriate extensions, takes and stores messages, and notifies subscribers when messages are left. Subscribers may send and transfer messages to other subscribers within the system. The VPS is easy to use, helping callers through the system with step-by-step voice prompts.

Unlike handwritten messages or those left with answering services, VPS messages are confidential; they are stored in a mailbox and retrieved only with the subscriber's password. Other advantages of the VPS are clarity and accuracy, which are commonly lacking with written messages. The messages come directly from the caller, in the caller's own voice. To further ensure accuracy, the system allows the sender to correct or change messages before saving them. Messages can be erased or transferred by the recipient.

1.1.2 Basic Operations

Greeting Callers:

The VPS greets callers with a prerecorded message that includes directions for leaving and editing messages. The VPS can list single-digit numbers for each available extension or mailbox. Callers who know the extension of the person they wish to reach may dial the extension number at any time. Callers with rotary phones are transferred to a preprogrammed destination (which is often an operator or the General Delivery Mailbox) to leave a message.

Sending Messages:

Callers can review and edit messages before leaving them in a mailbox. Subscribers can send messages to an individual or to several mailboxes at once. The message sender can then verify that the other subscriber has received the message.

Receiving Messages:

There are several different message notification methods that subscribers can use. They can choose to be notified by message waiting lamp, beeper, or a call from the system to another line. System programming determines whether a subscriber will be notified each time a message is left. (Subscribers can choose to receive message notifications differently depending on the time of day.) Mailbox parameters, which accommodate 5-100 messages, determine the maximum length of messages. If the system is connected using DPT Integration, subscribers can press a pre-assigned button to record conversations into their own mailboxes or other subscribers' mailboxes while talking on the phone. DPT Integration also allows subscribers to screen messages as they are being left, or intercept them if required.

1.1.3 VPS Limitations

The VPS does not support:

UCD functions

UCD (Uniform Call Distribution) is a service that distributes calls evenly among extensions; when all extensions are unavailable, it returns to callers to say that all extensions are busy. Calls can be forwarded by the VPS to UCD group floating extension numbers of the PBX (KX-TD500, KX-TD1232, KX-TD816, KX-TD308, and the KX-TDA/KX-TAW series). The call then rings at the next available phone.

The VPS supports UCD functions with very limited capabilities. Because the incoming call is forwarded as an intercom path and not a DIL (direct in line), the following items will not work:

- *time table*
- *overflow function*
- *DISA message from a DISA card*
- *IRNA*

Integration with the wrong PBX or with certain Key Systems presents limitations to the VPS' standard functions. We do not recommend these systems for integration with the VPS. The section 1.3.3 Which Phone Systems are Compatible? explains problems with compatibility.

1.2 SYSTEM ADMINISTRATION, MANAGEMENT, AND USE

1.2.1 System Administration

System Administration is accomplished by the installer using terminal emulation software. It concerns setting and changing system parameters and diagnosing system problems.

1.2.2 System Management

Two system functions are performed by the customer: System Management and Message Management.

System Management concerns changing system parameters through the System Manager's Mailbox.

Message Management concerns recording voice prompts through the Message Manager's Mailbox. These messages include Company Greetings, Company Name, Department Dialing menu, Custom Service menus, voice labels for System Group Distribution Lists, user prompts, multilingual selection menu and System Caller Names.

1.2.3 Subscriber Use

System users are called subscribers. Subscribers are assigned personal mailboxes which they can customize in the following ways:

- Setting their password
- Recording their names
- Recording personal greetings
- Setting covering extensions
- Setting Personal Custom Service
- Recording questions for an interview mailbox
- Setting the message reception mode
- Setting incomplete call handling status
- Setting call transfer status
- Entering Personal Group Distribution Lists
- Setting the message waiting lamp
- Setting notification by calling

1.3 SYSTEM BASICS

1.3.1 General

Initial Configuration and Expansion Capabilities

- The KX-TVS125 is initially configured with 4 ports and approximately 32 h of storage, and can be expanded to support 6 ports.
- The KX-TVS225 is initially configured with 4 ports and approximately 64 h of storage, and can be expanded to support 12 ports.
- The KX-TVS325 is initially configured with 4 ports and approximately 128 h of storage, and can be expanded to support 24 ports.

1.3.2 System Components

Main Cabinet—All Models

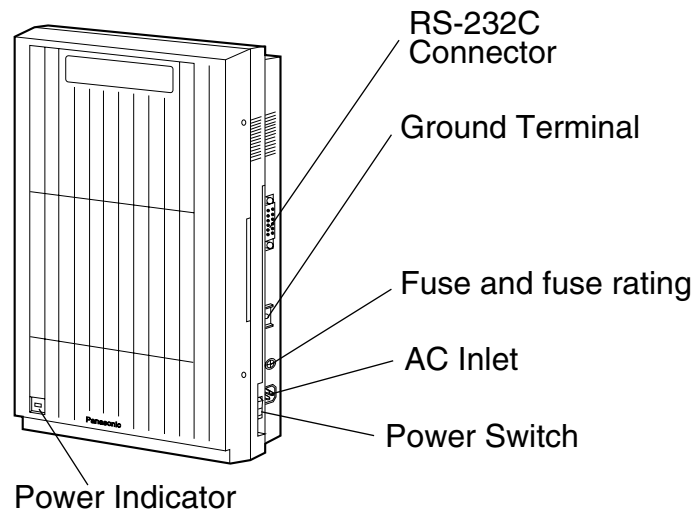

Note

EIA port is at SELV.

Inside View of the Main Cabinet—KX-TVS125

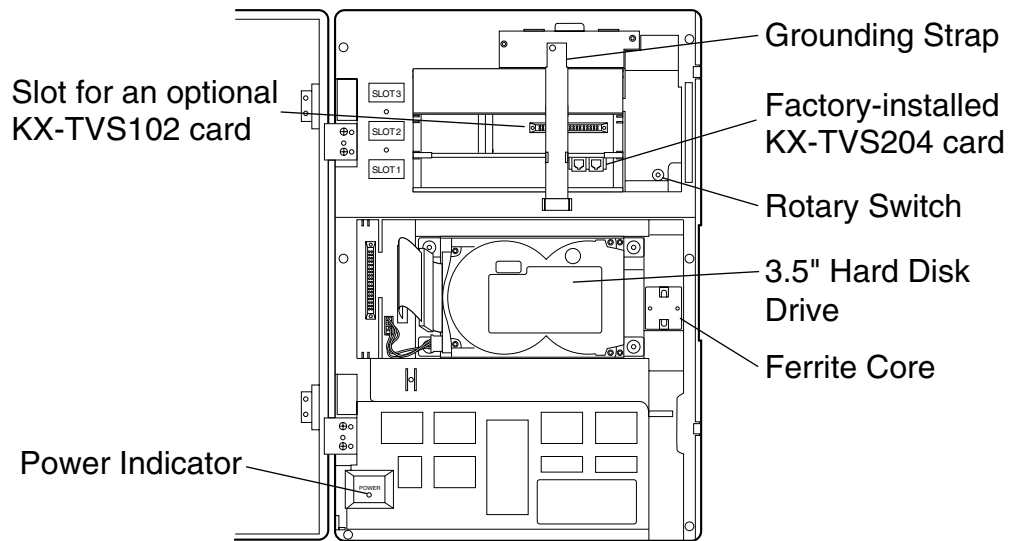

Note

Ports 1-6 are at TNV.

Inside View of the Main Cabinet—KX-TVS225

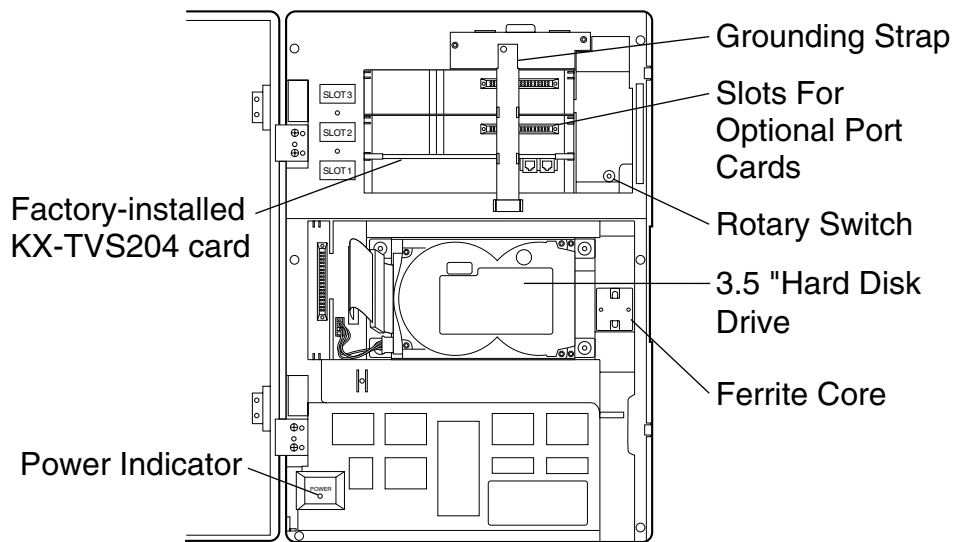

Note

Ports 1-12 are at TNV.

Inside View of the Main Cabinet—KX-TVS325

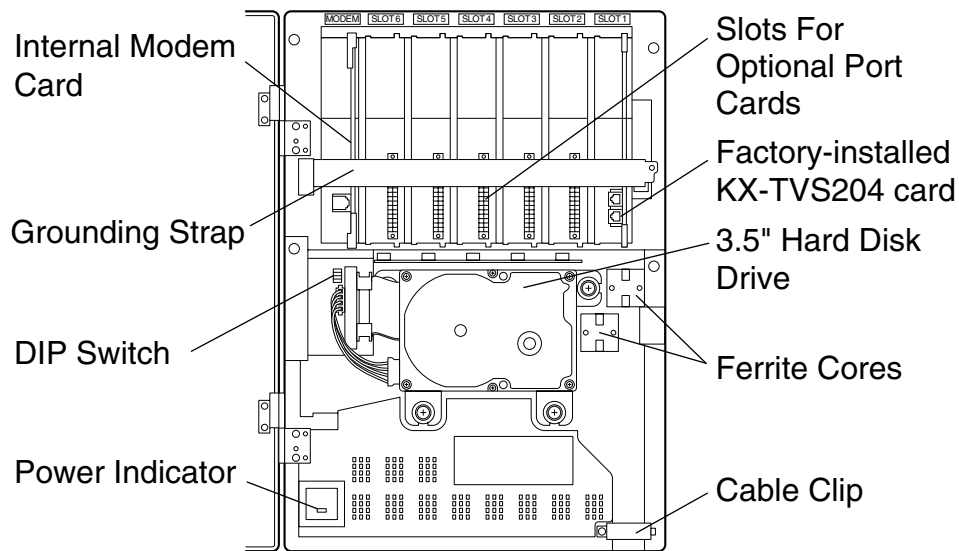

Note

Ports 1-24 are at TNV.

System Components

Power Indicator

Indicates the system status: when flashing, the system is off-line (not ready to receive calls).

RS-232C Connector

Connects an ASCII or VT terminal to the VPS that is necessary to program the system.

Ground Terminal

Must be connected to a ground source with less than 1 Ω resistance.

Fuse

Protects the system from power line surges and should only be replaced with the same type. Please see the fuse socket on the cabinet for the value of the fuse.

AC Inlet

Connects the power cable to an AC outlet dedicated to the VPS.

Power Switch

Starts the system and begins the self-test.

SAFETY PRECAUTION: When making any connections or removing the cover, be sure the power switch is switched off.











Internal Modem Card—KX-TVS325

Modem card for remote administration.

MODE (DIP Switch)—KX-TVS325

By setting one of the following positions and executing power down and up, you can achieve a desired result:

Table 1-1

Position	Additional Function
0 	Normal setting. (All switches in 0 position.)
1 	Initializes RS-232C parameters. RS-232C default parameters: 9,600, N, 8, 1
2* 	Auto Configuration is automatically executed and all ports are set for Automated Attendant service.
3* 	Auto Configuration is automatically executed and all ports are set for Voice Mail service.
4	Reserved.
5 	Initializes the VPS. Clears all voice data (except User 1 and User 2 prompts) and returns all system parameters to the default setting.
6 	Test Mode (Hard Disk Drive Read/Write Test)
7	Reserved.
8 	Initializes the VPS. Clears all voice data and returns all system parameters to the default setting. CAUTION User 1 and User 2 Prompts will be erased!
9-11	Reserved.
12 	All service prompts are set to System Prompts.
13 	All service prompts are set to User 1 Prompts.
14 	All service prompts are set to User 2 Prompts.
15	Reserved.

* For Panasonic KX-T series telephone systems with DPT Integration.
To change the position, use a pointed object, such as a pen, etc.

MODE (Rotary Switch)—KX-TVS125 and KX-TVS225

By setting one of the following positions and executing power down and up, you can achieve a desired result:

Table 1-2

Position	Additional Function
0	Normal setting.
1	Initializes RS-232C parameters. RS-232 default parameters: 9,600, N, 8, 1
2*	Auto Configuration is automatically completed and all ports are set for Automated Attendant service.
3*	Auto Configuration is automatically completed and all ports are set for Voice Mail service.
4	Reserved
5	Initializes the VPS. Clears all voice data (except User 1 and User 2 prompts) and returns all system parameters to the default setting.
6	Test Mode (Hard Disk Drive Read/Write Test)
7	Reserved
8	Initializes the VPS. Clears all voice data and returns all system parameters to the default setting. CAUTION User 1 and User 2 Prompts will be erased!
9	Reserved

* For Panasonic KX-T series telephone system with DPT Integration.

When setting the DIP/Rotary Switch to any position (except 0):

- 1. Disconnect the station wire(s) and wait a few minutes.***
- 2. Turn the power switch off at the VPS.***
- 3. Set the DIP/Rotary Switch.***
- 4. Turn the power switch back on at the VPS.***
- 5. Connect the station wire(s) to the VPS and wait approximately 5 min.***
- 6. Return the DIP/Rotary Switch to position 0.***

Grounding Strap

Protects the printed circuit board from static electricity.

(Ground) ***SAFETY PRECAUTION: Discharge any body static by touching the metal bar.***

Optional Port Cards

The following types of port cards can be installed in the VPS.

- *Four digital port expansion cards (KX-TVS204)*
- *Two digital/analog port expansion cards (KX-TVS102)*

SLOT 2 of the KX-TVS125 is not available for installing the KX-TVS204 card.

KX-TVS102 consists of the following 2 cards:

- *Telephone line interface card*
- *Digital processor (DSP) card*

The telephone line interface transmits and receives analog and digital signals to and from the telephone line. The analog input signal is digitized at a sampling rate of 8 kHz to create a 16-bit digital signal.

The DSP has the following features:

- *Voice Compression and Decompression*
- *Touchtone Detection*
- *Touchtone Generation*
- *Call Progress Tone Detection*

KX-TVS204 consists of a telephone line interface and a DSP. The telephone interface of the KX-TVS204 transmits and receives **ONLY** digital signals with a Panasonic KX-TD/KX-TDA/KX-TAW series or KX-TA1232 Digital PBX. The DSP has the same features as the KX-TVS102.

Hard Disk Drive

(One/system) Stores the proprietary system program, the system administration table, and the voice prompts; has the recording area for the messages from callers. (The hard disk is controlled by the central micro processor.)

Note

The actual Hard Disk Drive mounted on your VPS may look different from the one shown in the corresponding illustration provided in the beginning of this section.

CPU Board

(One/system) Main processing unit for the system. Comprised of central microprocessor, ROM, dynamic RAM, system controller, DIP Switch (KX-TVS325) or Rotary Switch (KX-TVS125 and KX-TVS225), and an RS-232C interface.

1.3.3 Which Phone Systems are Compatible?

We recommend integration with the following Panasonic phone systems:

- *Panasonic KX-TD500*
- *Panasonic KX-TD1232*
- *Panasonic KX-TA1232*
- *Panasonic KX-TD816*
- *Panasonic KX-TDA series*
- *Panasonic KX-TAW series*
- *Panasonic KX-TA624*
- *Panasonic KX-TD308*

We cannot guarantee adequate integration of the VPS with other PBX systems or with Key Systems. If the customer does not have a recommended Panasonic PBX system, be sure that the system has the features listed below.

The PBX should have the following features for successful integration:

- *Single line (tip/ring) port circuits (Some PBXs need an OPX card to provide this connection.)*
- *Station to station touchtone signaling*
- *Message Waiting Notification from an SLT (single-line telephone)*
- *Screened transfer from an SLT*
- *Message Waiting Notification on proprietary (multi-line) sets (message waiting lamp accessed by dialing on/off codes)*

If the PBX does not have these features, VPS operation will be limited.

See 3.1.4 PBX Requirements for Integration. You will find the following information about each feature listed:

- *Description*
- *Limitations of the system without the feature*
- *Tests to determine whether the PBX has the feature*

VOICE MAIL

The recommended Panasonic PBX systems have Follow-on ID and Inband Integration. When callers are transferred to an extension that is forwarded to Voice Mail, Follow-on ID sends callers directly to the mailbox. Without Follow-on ID, the caller would have to re-enter the mailbox number when connected to Voice Mail.

Touchtone Integration enables the VPS to recognize the current state of the call and improve its call handling performance. When enabled, the PBX informs the VPS of the status of the call (busy, answered, ringing, etc.) by sending a code with touchtones before sending the normal call progress tones. For example, when a caller hangs up before making a selection, the PBX sends # 9 to the VPS port that answered. This informs the VPS that the caller has hung up. Upon receiving these digits, the VPS goes on-hook and is ready to handle another call.

DPT Integration is available when the VPS is connected to a Panasonic KX-TD/KX-TDA/KX-TAW series or KX-TA1232 PBX (depending on the software version). This DPT Integration provides the VPS with more information than Touchtone Integration. This information enables the system to identify the extension number of the caller, know where from and why the call is

forwarded, and recognize what the caller wants to do. Some features are available only with DPT Integration (Remote Call Forwarding Set, Live Call Screening, Two-Way Recording, Two-Way Transfer, One-Touch Two-Way Transfer (available only with KX-TDA/KX-TAW series), Direct Mailbox Access, Intercom Paging, Auto Configuration, Caller Name Announcement [system/personal], Caller ID Call Routing, DID Call Routing, Personal Greeting for Caller ID, Time Synchronization with PBX, Toll Saver).

1.3.4 Installer Equipment and Software Requirements

The installer **must** have a personal computer or data terminal equipped with terminal emulation software. We suggest that you use something like HyperTerminal by HILGRAEVE. Use the personal computer to program the VPS. Terminal emulation software enables the keyboard to be used as a data entry device.

While both the personal computer and data terminal are working, the personal computer allows screens to be saved in a file throughout the process. It is often helpful to retrieve these files later if technical support is needed.

1.3.5 Specifications

Table 1-3

Compression Rate:	32 Kbps
Ports (maximum):	<ul style="list-style-type: none"> • KX-TVS125: 6 ports • KX-TVS225: 12 ports • KX-TVS325: 24 ports
Voice Storage (approximate):	<ul style="list-style-type: none"> • KX-TVS125: 32 h • KX-TVS225: 64 h • KX-TVS325: 128 h
Custom Services:	100
Message Retention:	1 to 30 days or unlimited
Number of Mailboxes:	<ul style="list-style-type: none"> • KX-TVS125: 62 Subscriber and 2 Manager Mailboxes • KX-TVS225 and KX-TVS325: 1022 Subscriber and 2 Manager Mailboxes
Number of Messages per Mailbox:	100 maximum (programmable)
Internal Modem (KX-TVS325 only):	Maximum data transfer rate at 33600 bps.

1.3.6 Hardware

Table 1-4

KX-TVS125	KX-TVS225	KX-TVS325
<ul style="list-style-type: none"> • One Hard Disk Drive • One Port Card (KX-TVS204) • One Optional Port Card Slot for KX-TVS102 Card • One RS-232C Connector • One Rotary Switch 	<ul style="list-style-type: none"> • One Hard Disk Drive • One Port Card (KX-TVS204) • Two Optional Port Card Slots for KX-TVS102 and/or KX-TVS204 Cards • One RS-232C Connector • One Rotary Switch 	<ul style="list-style-type: none"> • One Hard Disk Drive • One Port Card (KX-TVS204) • One Internal Modem Card • Five Optional Port Card Slots for KX-TVS102 and/or KX-TVS204 Cards • One RS-232C Connector • One DIP Switch (4-bit)

1.3.7 Expansion Capabilities

Expansion requires additional port card(s): KX-TVS102 or KX-TVS204.

- The KX-TVS102 card has 2 digital/analog ports, and the ports are increased in increments of 2.
- The KX-TVS204 card has 4 digital ports, and the ports are increased in increments of 4.

Both the KX-TVS102 and the KX-TVS204 card can be installed in all models. (But SLOT 2 of the KX-TVS125 is not available for installing the KX-TVS204 card.)

1.3.8 Internal Modem Card (KX-TVS325 only)

An internal modem card is installed in the KX-TVS325 prior to factory shipment. This card is necessary for programming and maintenance from remote locations.

The maximum data transfer rate of the internal modem is 33600 bps.

1.3.9 Recommendations for System Configuration

General guideline: a ratio of 6/1 (for every 6 lines, 1 port). There are 2 questions to ask when considering how many ports are desirable:

- Are the ports answering all incoming calls or just forwarded/transferred calls?
- If they are answering incoming calls, how busy are the lines?

The guideline above (6/1) usually works well with moderate traffic. However, this may have to be modified for heavy traffic. Recommendations are outlined in the following charts.

Notes

- The KX-TVS125 can support a maximum of 6 ports.
- The KX-TVS225 can support a maximum of 12 ports.
- The KX-TVS325 can support a maximum of 24 ports.

PBX CO Lines	VPS Port
1-6	1
7-12	2
13-18	3
19-24	4
25-30	5
31-36	6
37-42	7
43-48	8
49-54	9
55-60	10
61-66	11
67-72	12
73-78	13
79-84	14
85-90	15
91-96	16
97-102	17
103-108	18
109-114	19
115-120	20
121-126	21
127-132	22
133-138	23
139-144	24

One port may not support an Automated Attendant configuration with 5 CO lines. The preceding recommendations for Automated Attendant ports may have to be modified for heavy traffic.

PBX CO Lines	VPS Port
1-4	1
5-8	2
9-12	3
13-16	4
17-20	5
21-24	6
25-28	7
29-32	8
33-36	9
37-40	10
41-44	11
45-48	12
49-52	13
53-56	14
57-60	15
61-64	16
65-68	17
69-72	18
73-76	19
77-80	20
81-84	21
85-88	22
89-92	23
93-96	24

1.4 VOICE MAIL INTEGRATION

1.4.1 General

DPT Integration

To the Panasonic KX-T series PBX that uses DPT Integration, the VPS ports look like digital extensions. The PBX thinks that the VPS is a digital phone, and the VPS mimics all actions of a digital set. Another advantage of DPT Integration is that the 2B+D communication provides 2 VPS ports for each Digital Station port. Communication between the VPS and the PBX through DPT Integration requires the proper software level in the PBX and 4-wire connections for each port. To communicate between the VPS and the PBX through DPT Integration, the PBX and VPS must be programmed to work together.

DPT Integration is available when the VPS is connected to a KX-TD/KX-TDA/KX-TAW series or KX-TA1232 PBX with the proper software level.

Note

To use DPT Integration, the lowest numbered jack of the VPS must be connected to the lowest numbered jack assigned as a Voice Mail Port Assignment in the PBX. See the DPT connection example(s) for your VPS model in the following section,

1.4.2 Connection Examples—KX-TVS125,

1.4.3 Connection Examples—KX-TVS225, or

1.4.4 Connection Examples—KX-TVS325.

Connect the other jacks to the VPS in the order of Voice Mail Port Assignment in the PBX.

Inband/None Integration

To the PBX, the VPS looks like SLT sets through standard single-line (tip/ring) telephone interfaces.

1.4.2 Connection Examples—KX-TVS125

DPT Integration

For example, when you mount 1 KX-TVS204 card and 1 KX-TVS102 card, you can use 6 VPS ports in total by connecting 3 jacks of the KX-TD/KX-TDA/KX-TAW series or KX-TA1232 PBX to 3 jacks of the KX-TVS125.

Notes

- The KX-TA1232 supports a maximum of 4 jacks as VPS ports.
- SLOT 2 of the KX-TVS125 is not available for installing the KX-TVS204 card.

Connection Example (KX-TVS204×1, KX-TVS102×1, DPT Integration Mode)

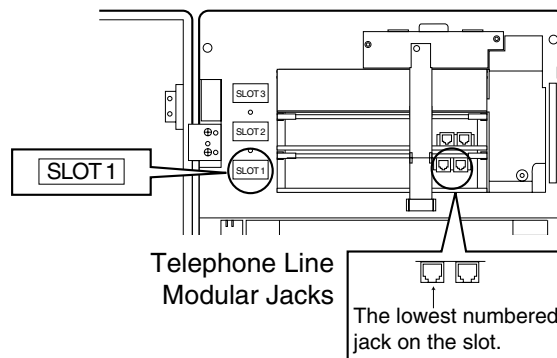
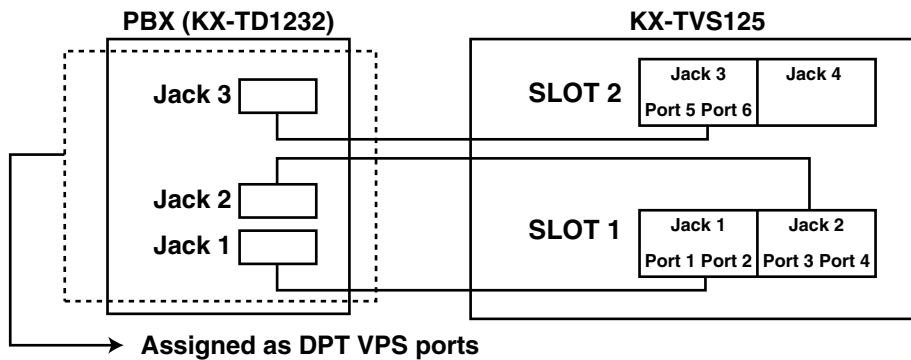

Connect the odd-numbered jack on the KX-TVS102 card to your PBX (see the diagram above). The VPS will support 2 ports for the KX-TVS102 card, with only one jack connected.

Note

Do not connect the even-numbered jacks on the KX-TVS102 card.

Inband/None Integration

Connection Example (KX-TVS102 × 2, Inband/None Integration Mode)

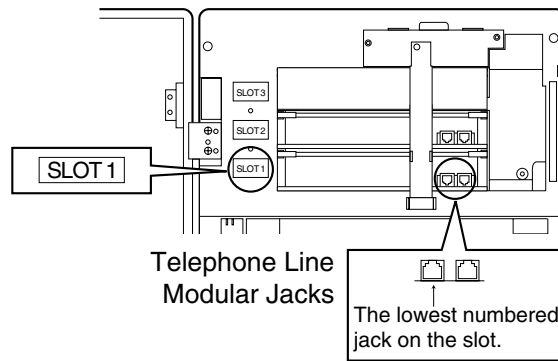
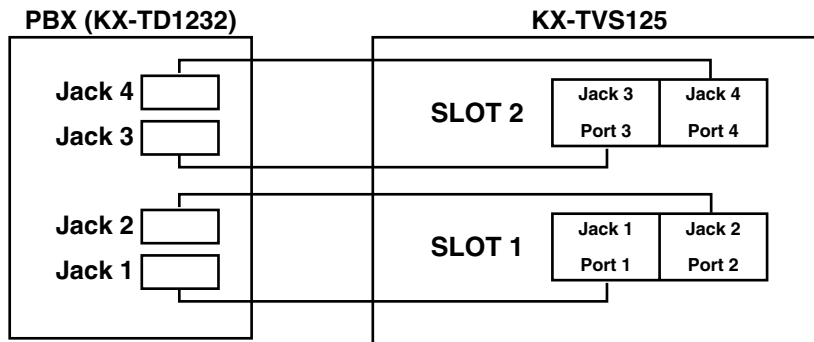

Connect both jacks on each KX-TVS102 card to your PBX (see the diagram above). The VPS will support 2 ports for each KX-TVS102 card, with both jacks connected.

1.4.3 Connection Examples—KX-TVS225

DPT Integration

For example, when you mount 3 KX-TVS204 cards, you can use 12 VPS ports in total by connecting 6 jacks of the KX-TD/KX-TDA/KX-TAW series or KX-TA1232 PBX to 6 jacks of the KX-TVS225.

Note

The KX-TA1232 supports a maximum of 4 jacks as VPS ports.

Connection Example (KX-TVS204×3)

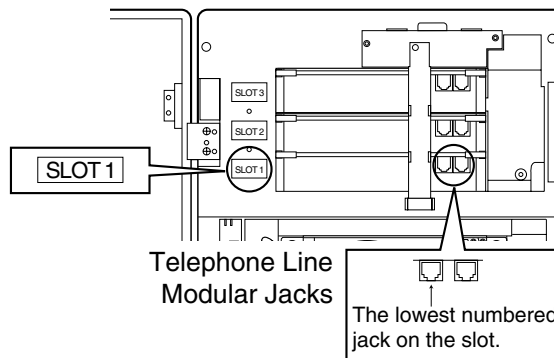
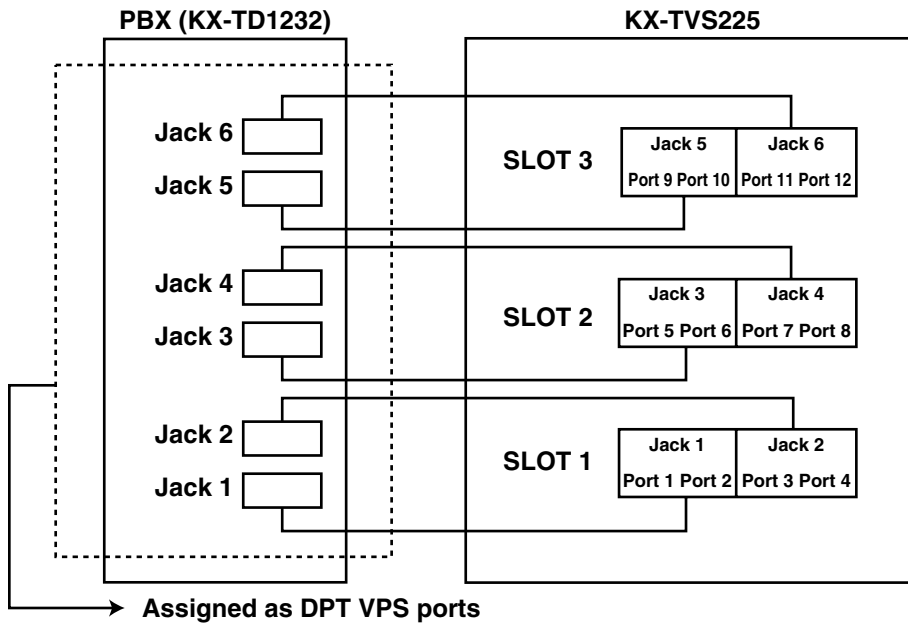

Connection Example (KX-TVS102 ×3, DPT Integration Mode)

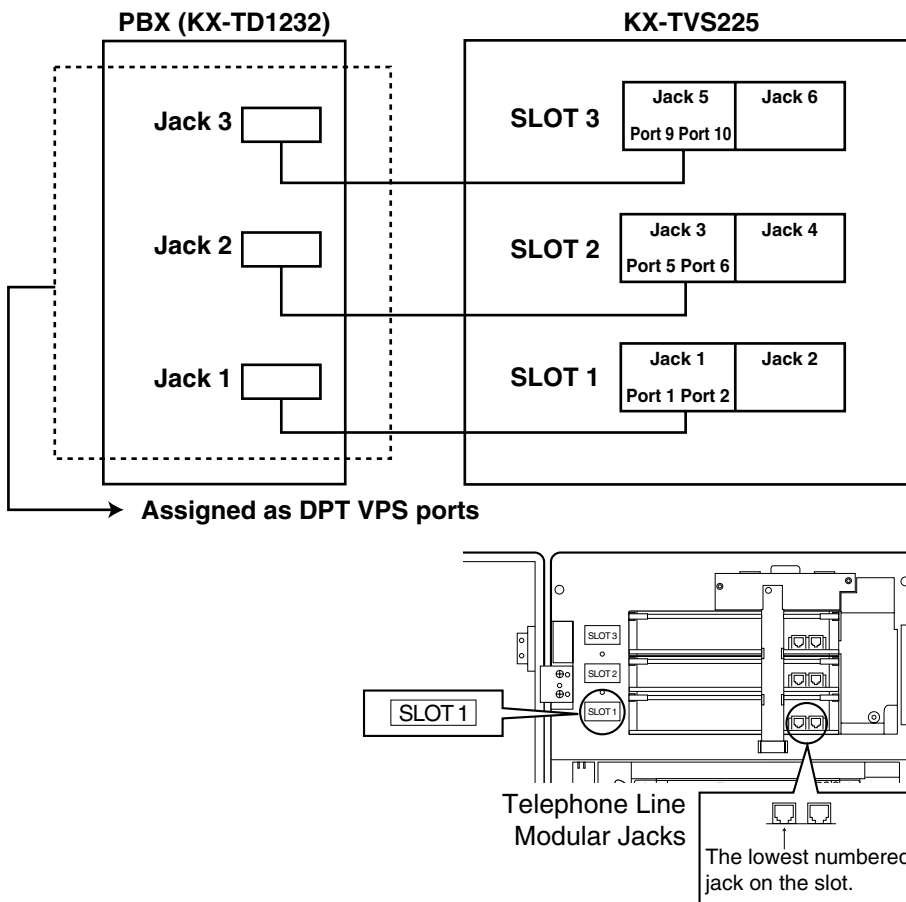

Connect the odd-numbered jack on each KX-TVS102 card to your PBX (see the diagram above). The VPS will support 2 ports for each KX-TVS102 card, with only one jack connected.

Note

Do not connect the even-numbered jacks on the KX-TVS102 card.

Inband/None Integration

Connection Example (KX-TVS102×3, Inband/None Integration Mode)

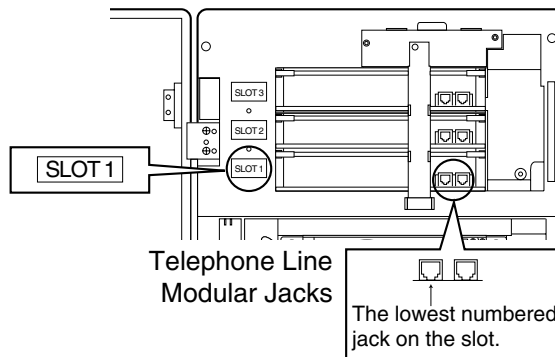
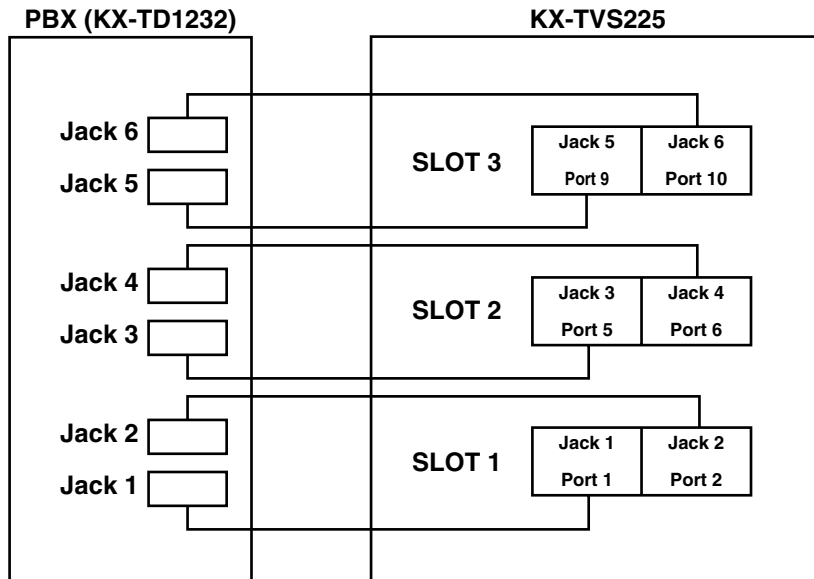

Connect both jacks on each KX-TVS102 card to your PBX (see the diagram above). The VPS will support 2 ports for each KX-TVS102 card, with both jacks connected.

1.4.4 Connection Examples—KX-TVS325

DPT Integration

For example, when you mount 6 KX-TVS204 cards, you can use 24 VPS ports in total by connecting 12 jacks of the KX-TD/KX-TDA/KX-TAW series or KX-TA1232 PBX to 12 jacks of the VPS.

Note

The KX-TA1232 supports a maximum of 4 jacks as VPS ports.

Connection Example (KX-TVS204 × 6)

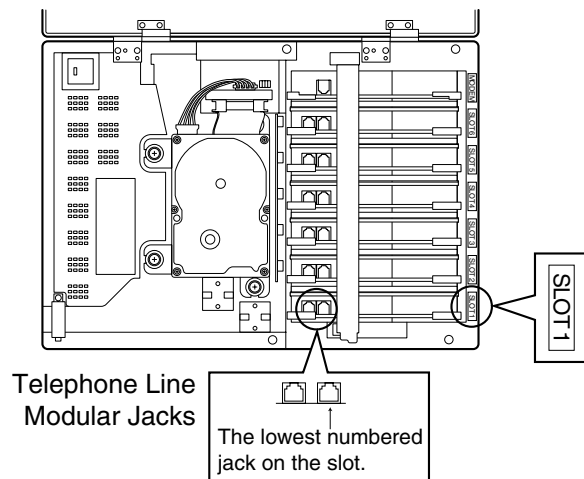
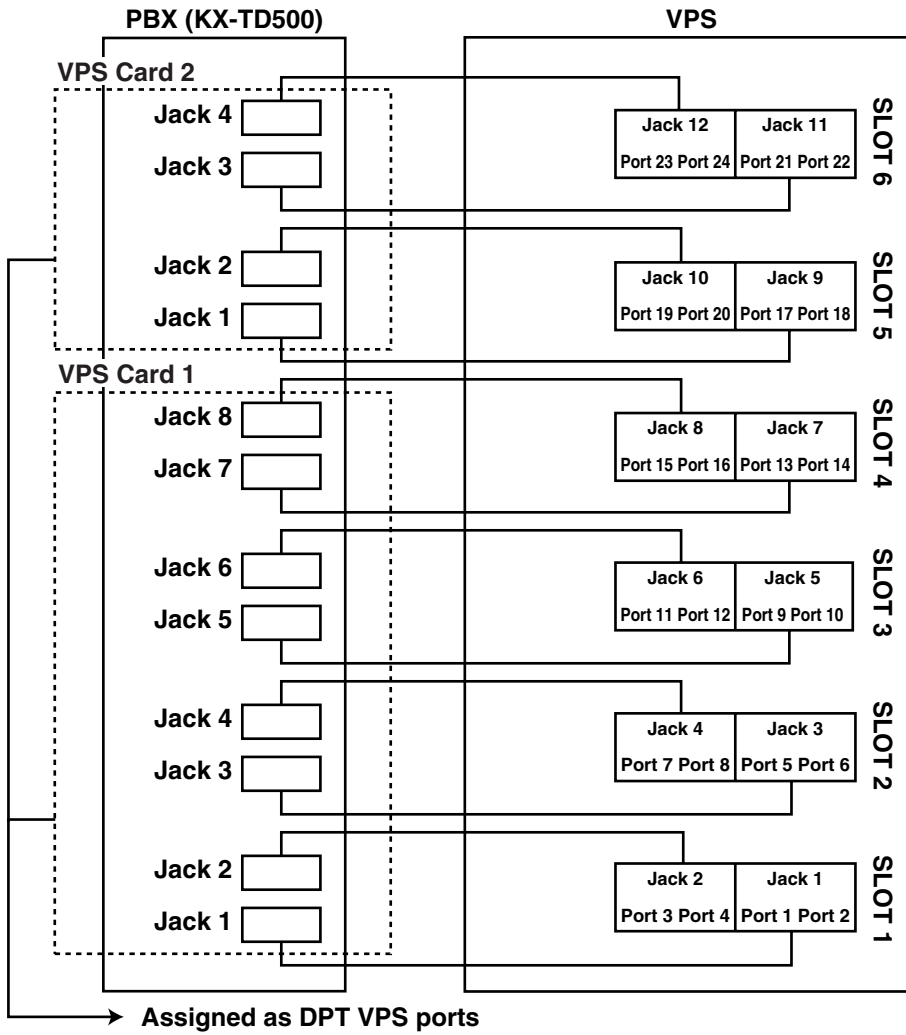

Connection Example (KX-TVS102×6, DPT Integration Mode)

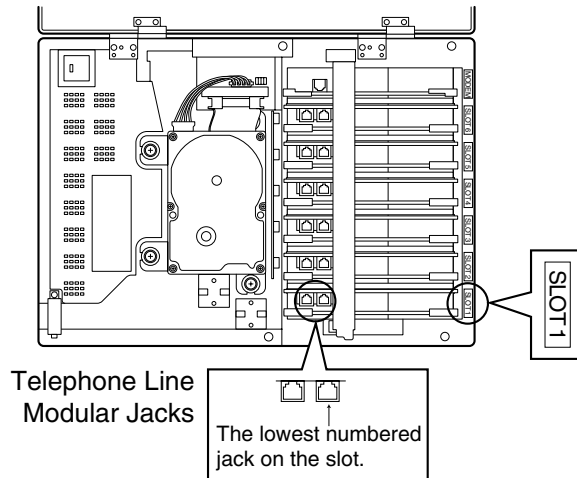
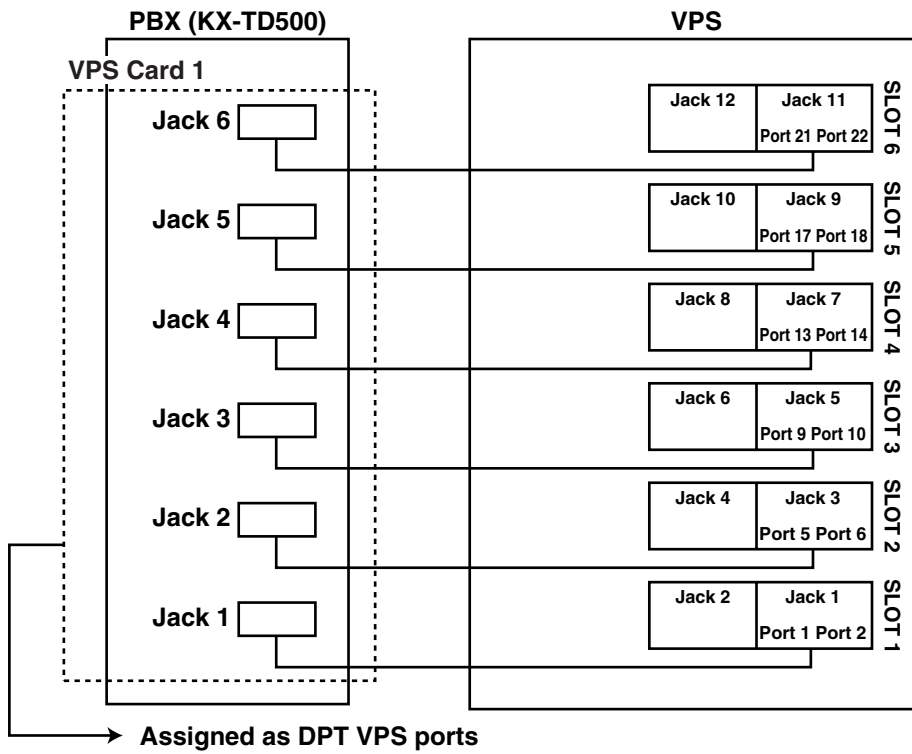

Connect the odd-numbered jack on each KX-TVS102 card to your PBX (see the diagram above). The VPS will support 2 ports for each KX-TVS102 card, with only one jack connected.

Note

Do not connect the even-numbered jacks on the KX-TVS102 card.

Inband/None Integration

Connection Example (KX-TVS102×6, Inband/None Integration Mode)

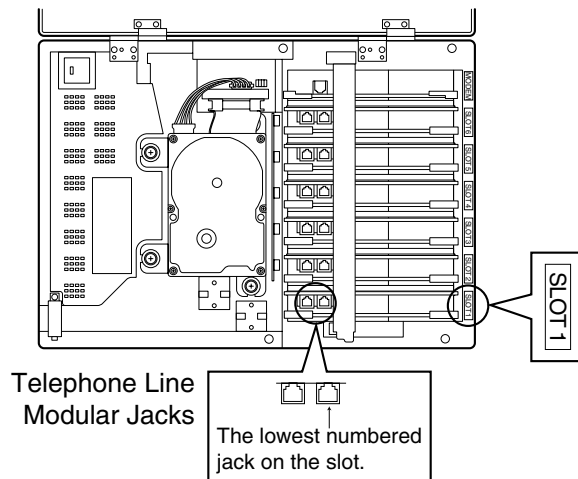
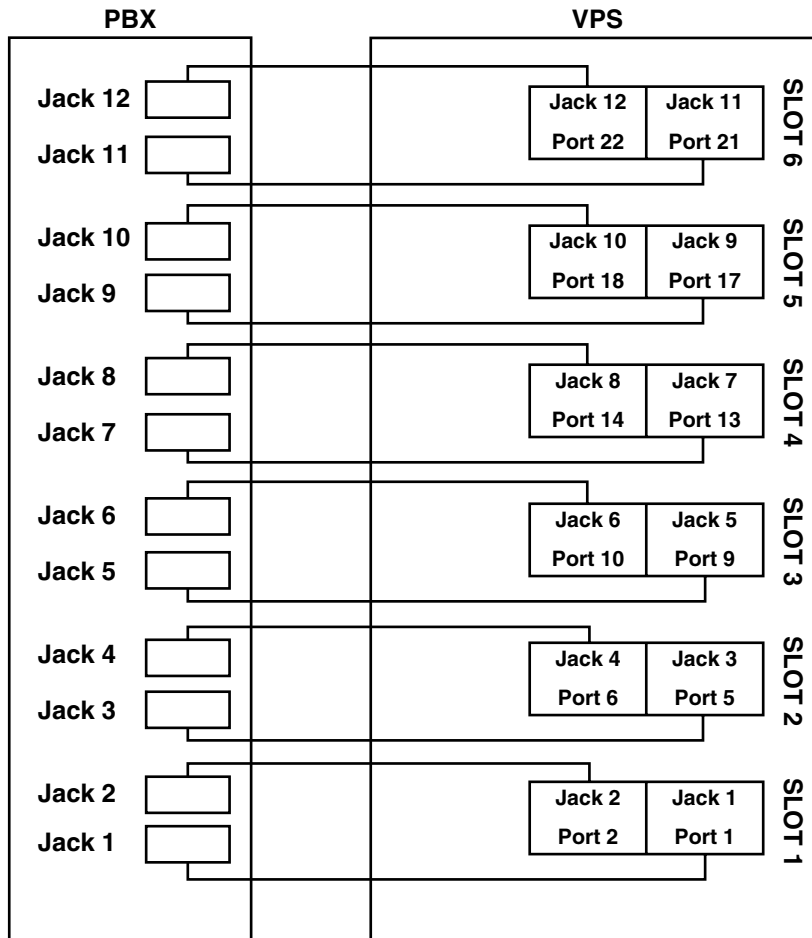

Connect both jacks on each KX-TVS102 card to your PBX (see the diagram above). The VPS will support 2 ports for each KX-TVS102 card, with both jacks connected.

Section 2
INSTALLATION

2.1 SAFETY PRECAUTIONS

Please read the following precautions before installing the VPS.

2.1.1 Installation

The VPS needs to be mounted on a wall. Improper placement of the system may result in malfunction, noise, or discoloration. Avoid installing the VPS in the following places:

- *in direct sunlight; in hot, cold, or humid places*
- *in new areas where there are thermal springs, etc. (where sulfuric gas may damage the equipment or contacts).*
- *where shocks or vibrations are frequent or strong.*
- *in dusty places or places where water or oil may come in contact with the unit.*
- *near high frequency generating devices such as sewing machines, elevators or electric welders.*
- *on or near computers, telexes, or other office equipment; near microwave ovens or air conditioners. (Ideally, the VPS should not be in the room with these items and should be at least 1.8 m {6 feet} away from televisions.)*

Do not obstruct the areas around the PBX and the VPS. Both require space above for cooling and space on the sides for maintenance and inspection.

2.1.2 Wiring

- *To assure good quality telephone connection, it is recommended new and modifications to existing installation of customer premise wiring shall use solid twisted pair copper conductors with minimum 24 gauge that comply with the electrical specifications for Category 3 wiring as detailed in ANSI/EIA/TIA-570A Building Wiring Standards.*
- *Do not wire the telephone cable parallel to an AC power source, computer, etc. If cables are run near those wires, shield them with metal tubing or use shielded cables and ground the shields.*
- *Use protectors if running cables on the floor. Avoid running cables under carpets.*
- *Avoid sharing a 120 V AC power supply for computers, telexes, and other office equipment with the VPS. Induction noise from such equipment may interrupt the VPS operation.*

When making any connections or removing the cover, be sure the power switch is turned off.

When installing telephone wiring, basic safety precautions should always be followed to reduce the risk of fire, electric shock and injury to persons, including the following:

- Never install telephone wiring during a lightning storm.
- Never install telephone jacks in wet locations unless the jack is specifically designed for wet locations.
- Never touch uninsulated telephone wires or terminals unless the telephone line has been disconnected at the network interface.
- Use caution when installing or modifying telephone lines.

Note

If you live in an area that can have frequent power failures, we strongly recommend that you purchase a suitable UPS (uninterruptible power supply) for your VPS (and PBX if needed). The power rating of your VPS may be found in the specifications.

2.1.3 Environmental Requirements

The hard disk is sensitive to cold, heat, dryness, humidity, shock, vibration, and magnetic fields. Please observe the conditions specified below.

Table 2-1 Hard Disk Drive Usage Environment

Operating Temperature:	5 °C to 40 °C {41 °F to 104 °F}
Operating Humidity:	See Graph 1 below.
Shock:	Under 5 G
Vibration:	5 Hz to 22 Hz : 0.0042 cm {0.020 inch} displacement; double amplitude, 1 octave per minute. 23 Hz to 350 Hz : Under 0.5 G
Magnetic Field:	DC : 0.6 mT to 700 kHz : 0.7 μT 700 kHz to 1.5 MHz : 3 μT

Graph 1: Allowable Relative Humidity vs. Temperature

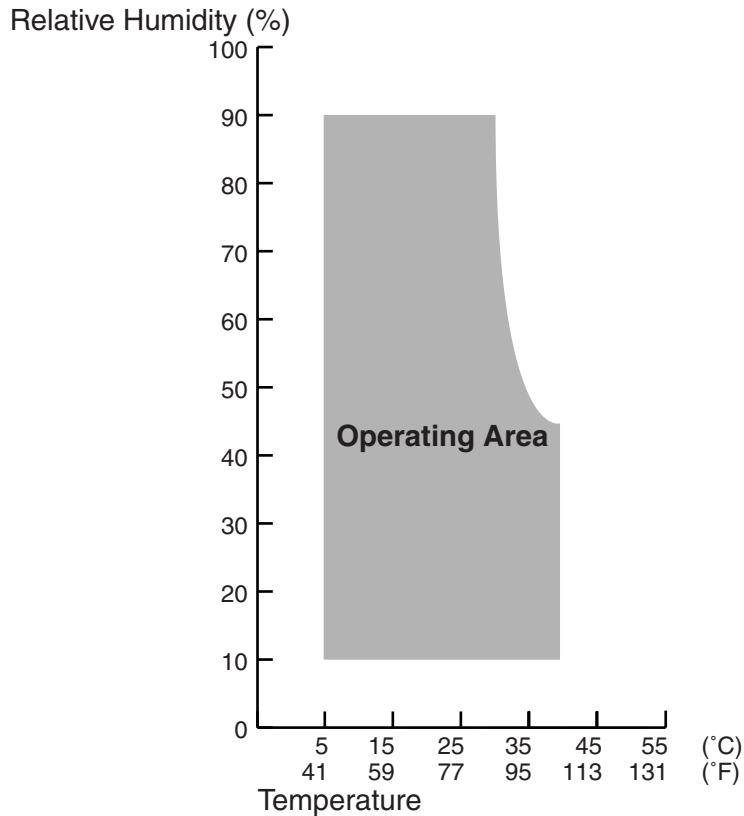

2.2 UNPACKING

Unpack the box and check the items below.

Table 2-2

Main Unit	1
AC Cord	1
Screws (Wall Mounting)	3
Anchor Plugs (Wall Mounting)	3

2.3 MOUNTING THE VPS ON THE WALL

The wall where the VPS is to be mounted must be able to support the weight of the VPS. If screws other than the ones supplied are used, use the same-sized diameter screws as the enclosed ones.

To Mount on a Wooden Wall:

1. Place the template (included) on the wall to mark the 3 screw positions.

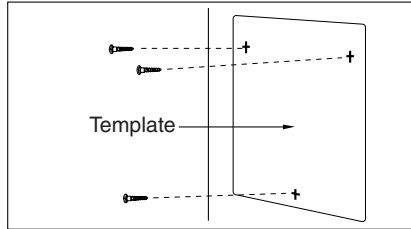

2. Install the 3 screws (included accessories) into the wall.

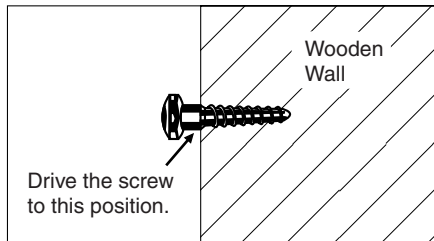

3. Hook the unit on the screw heads.

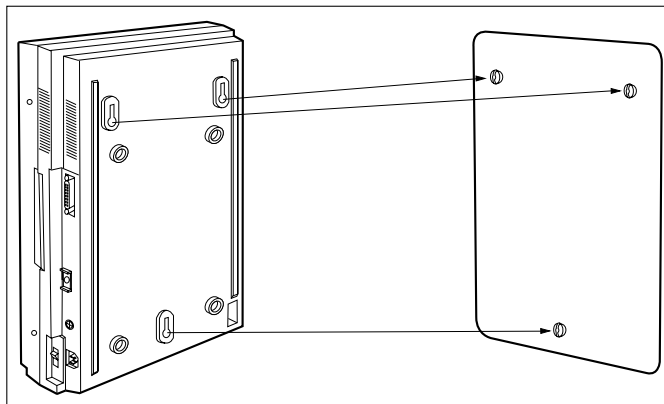

To Mount on a Concrete or Mortar Wall:

1. Place the template on the wall to mark the 3 screw positions.

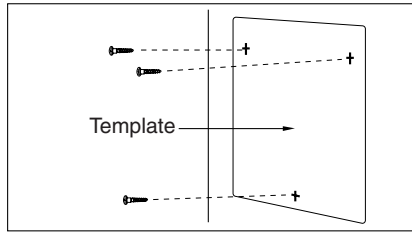

2. Drill 3 holes and drive the anchor plugs (included) with a hammer, flush with the wall.

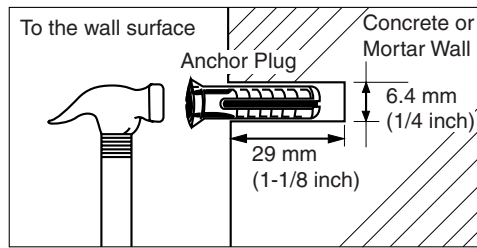

3. Install the 3 screws into the anchor plugs.

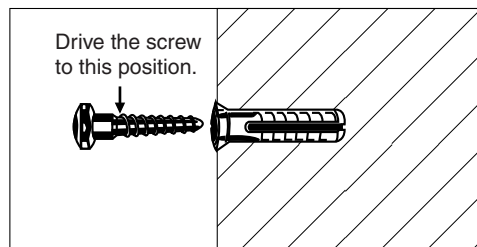

4. Hook the unit on the screw heads.

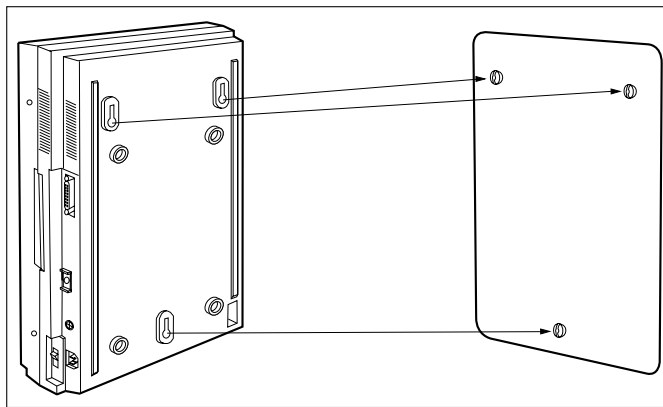

2.4 FRAME GROUND CONNECTION

IMPORTANT!!!

Connect the frame of the main unit to the ground.

1. Loosen the screw.
2. Insert the grounding wire.
3. Tighten the screw.
4. Connect the grounding wire to the ground.

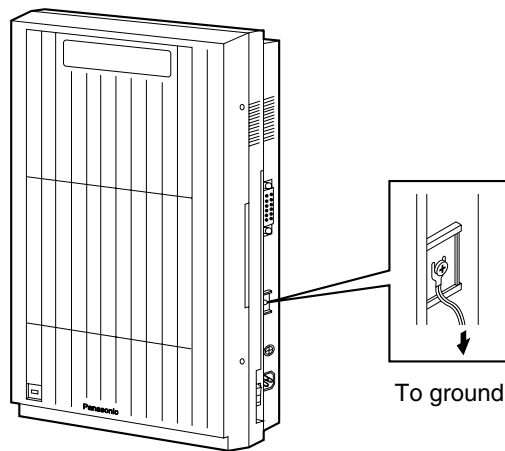

In most of the continental United States, the ground provided by the "Third wire ground" at the commercial power outlet will be satisfactory. However, in a small percentage this ground may be installed incorrectly. Therefore, the following test procedure should be performed.

Test Procedure

1. Obtain a suitable voltmeter and set it for a possible reading of up to 250 V AC.
2. Connect the meter probes between the 2 main AC voltage points on the wall outlet. The reading obtained should be 108 V AC-132 V AC.
3. Move one of the meter probes to the third prong terminal (GND). Either the same reading or a reading of 0 V should be obtained.
4. If a reading of 0 V at 1 terminal and a reading of 108 V AC-132 V AC at the other terminal is not obtained, the outlet is not properly grounded. This condition should be corrected by a qualified electrician (per article 250 of the National Electrical Code).
5. If a reading of 0 V at 1 terminal and a reading of 108 V AC-132 V AC at the other terminal is obtained, then set the meter to the "OHMS/RX1" scale, place 1 probe at the GND Terminal and the other probe at the terminal which gave a reading of 0 V. A reading of less than 1 Ω should be obtained. If the reading is not obtained, the outlet is not adequately grounded. See a qualified electrician.

2.5 INSTALLATION STEPS

The following is an overview of the standard installation process using DPT Integration. When necessary, other sections in this manual have been referenced for more detailed descriptions or instructions.

1. Obtain a list of current users, their extension numbers, their departments, and the type of systems they use (mailbox, no mailbox, beeper, car phone, etc.).
2. Assess your customers' needs before setting up the system. You will save yourself time later by giving customers what they need up front. Ask the office manager how the VPS will be used. Give examples.
Recommend that your customer use a word processor to log the greetings. You will find these files much more easily than the worksheet pages if you need to make changes down the road.
3. Connect the power cord to the VPS, then turn power switch on.

CAUTION

The power supply cord is used as the main disconnect device. Ensure that the socket-outlet is located/installed near the equipment and is easily accessible.

4. If necessary, install optional port expansion cards (see 2.6 INSTALLING PORT EXPANSION CARDS: KX-TVS102 OR KX-TVS204).
5. Standard Initialization (For DPT Integration Connection)
 - a) Program the ports of the PBX for voice processing (see Section 4 INTEGRATING THE VPS WITH THE PANASONIC KX-T DIGITAL PBX).
Program the KX-TD500, the KX-TD1232, the KX-TA1232, the KX-TD816, the KX-TD308, the KX-TDA series, or the KX-TAW series for Voice Mail integration.
 - KX-TD500, KX-TD816, KX-TD1232, KX-TA1232, KX-TD308, KX-TDA series, KX-TAW series

Program may be performed on-site or at the office.

All memory is stored and will be retained when the unit is powered up as long as the DIP/Rotary Switch has been reset to position [0] prior to turning the unit off.

- b) Turn the power switch off at the VPS.
- c) Plug station wire(s) from the PBX into VPS (see 2.7 CONNECTIONS).
- d) Connect the personal computer to the VPS with a Null Modem Cable (see 2.8.2 Connecting the RS-232C Cable).
- e) Set the DIP/Rotary Switch to position 5.
- f) Turn the power switch back on at the VPS.
- g) Wait until the "warning" appears on the screen.
- h) Set the DIP/Rotary Switch back to position 0.

CAUTION

If the DIP/Rotary Switch is not reset to position 0 after initialization, all programming will be lost when the voice processor loses power!

6. Perform Quick Setup (see Section 5 CUSTOMIZING THE SYSTEM).
7. Check Quick Setup:
 - The Power Indicator on the Voice Processor should be solid.
 - The screen output should be: [On Line].

If you do not see the "On Line" message, check the following:

- The line cord to the Voice Processor has 4 conductors.
 - The programming on the KX-TD816, KX-TD1232, KX-TA1232 or KX-TD308 is correctly set in System Program [117].
 - The programming on the KX-TD500 is correctly set in the "1-4 VPS (DPT) Port Assignment" screen.
 - The programming on the KX-TDA/KX-TAW series is correctly set in the "3.Groups-7.VM(DPT) Group-2.Unit Setting" and "1.Configuration-8.Extension Port" screens.
8. Set up Class of Service (COS) for each user. Customize voice prompts if necessary (see Appendix B SYSTEM ADMINISTRATOR'S GUIDE).
 9. Perform Administrative Program through a personal computer (see Appendix B SYSTEM ADMINISTRATOR'S GUIDE).

CAUTION

Do not turn the power off while the VPS is activated so as not to cause malfunction. To turn the power off after installing the VPS, unplug the power cord from the VPS a few minutes after disconnecting station wire(s).

2.6 INSTALLING PORT EXPANSION CARDS: KX-TVS102 OR KX-TVS204

2.6.1 General

Port Expansion Cards

- The KX-TVS102 card can be installed in the KX-TVS125, KX-TVS225, and KX-TVS325. One KX-TVS102 card can support 2 VPS ports, under either Inband or DPT Integration.
- The KX-TVS204 card can be installed in the KX-TVS125, KX-TVS225, and KX-TVS325 (but SLOT 2 of the KX-TVS125 is not available for installing the KX-TVS204 card). One KX-TVS204 card can support 4 VPS ports, under DPT Integration.

Expansion Capabilities of the VPS

- The KX-TVS125 can handle up to 6 ports simultaneously when 1 KX-TVS204 port card and 1 KX-TVS102 port card are installed.
- The KX-TVS225 can handle up to 12 ports simultaneously when 3 KX-TVS204 port cards are installed.
- The KX-TVS325 can handle up to 24 ports simultaneously when 6 KX-TVS204 port cards are installed.

The KX-TVS125, KX-TVS225, and KX-TVS325 have one port expansion card (KX-TVS204) installed prior to factory shipment.

CAUTION

Before installing an optional port card, it is very important that the power to the unit be turned off. Before beginning the actual installation and touching the card or any circuitry within the unit, discharge any static electricity from your body by touching the grounding strap. This is a critical step that must be performed to protect the printed circuit board and any other electronic components from static electricity. Refer to the manual accompanying the optional card concerning the precautions that must be taken and the steps for completing the installation.

2.6.2 Installing the KX-TVS102 or KX-TVS204 Port Card

1. Remove the adhesive tape from the card.

KX-TVS102 Card

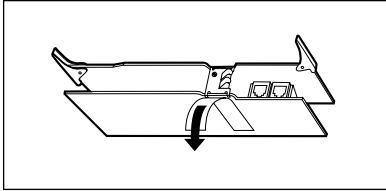

KX-TVS204 Card

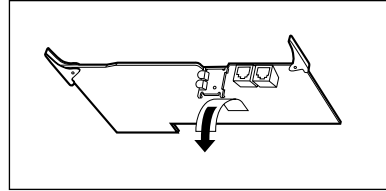

2. (KX-TVS102 only) Loosen, remove and discard the screw under the tape with a screwdriver.

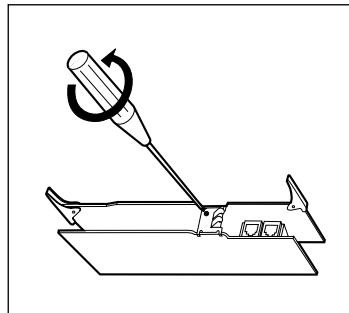

3. Loosen two screws on the right side of the main unit, then open the front cover in the direction of arrow (A).

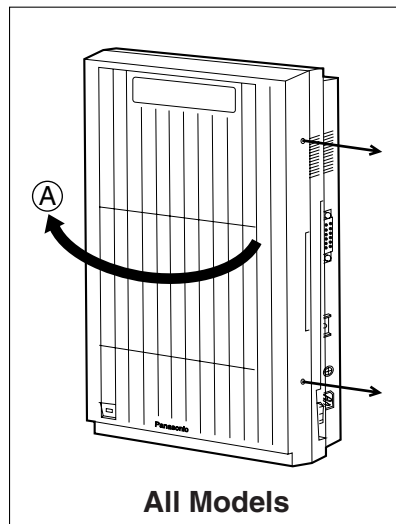

- Loosen the screw on the grounding strap, then remove the strap from the unit.

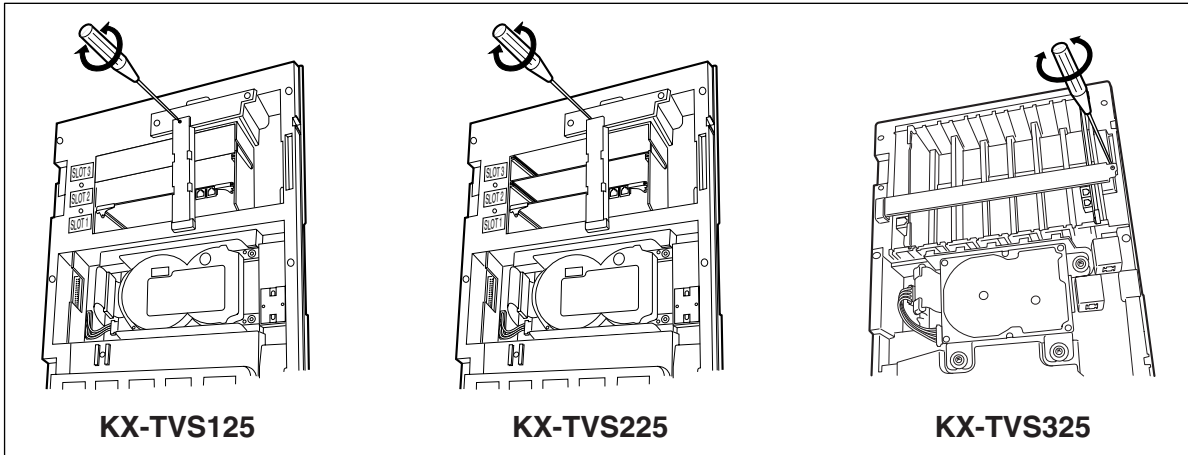

- Insert the optional port card into SLOT 2 using the guide rails.

KX-TVS102 Card

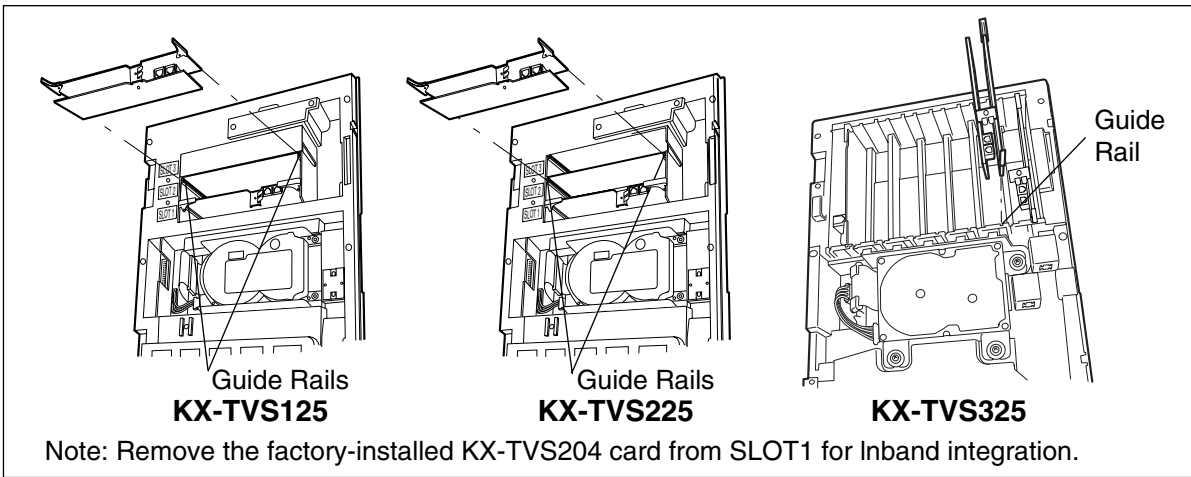

Note: Remove the factory-installed KX-TVS204 card from SLOT1 for Inband integration.

KX-TVS204 Card

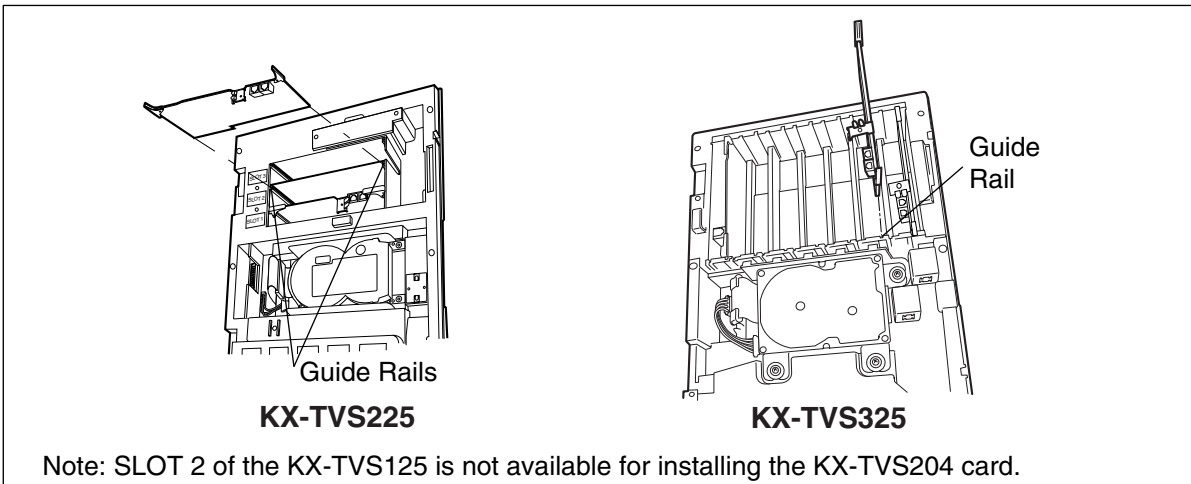

Note: SLOT 2 of the KX-TVS125 is not available for installing the KX-TVS204 card.

6. Press the latches at both ends of the card firmly, then fix the grounding strap to the unit with a screwdriver.

KX-TVS102 Card

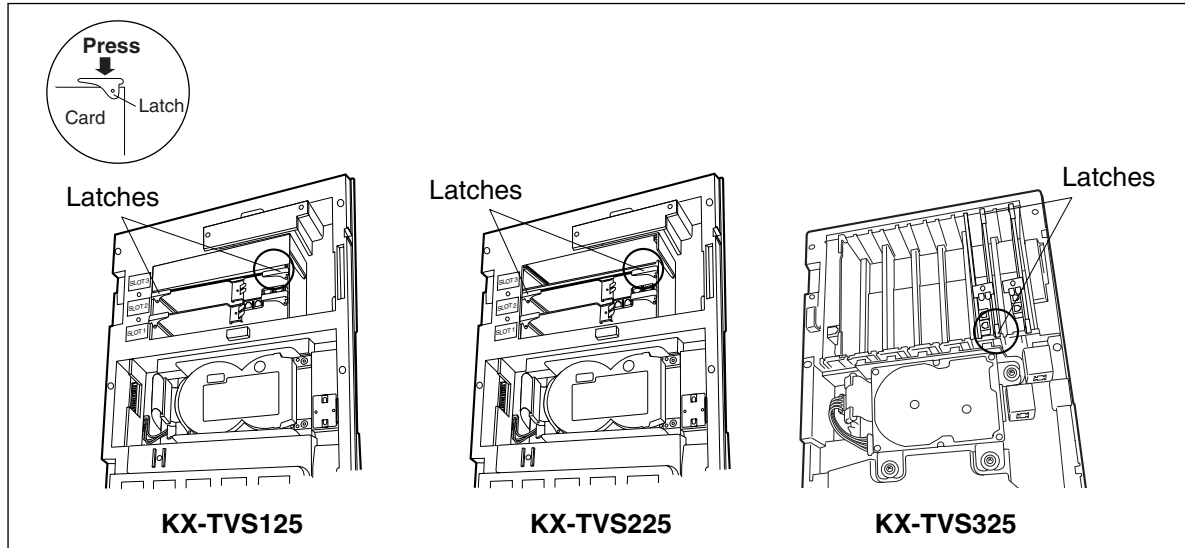

KX-TVS204 Card

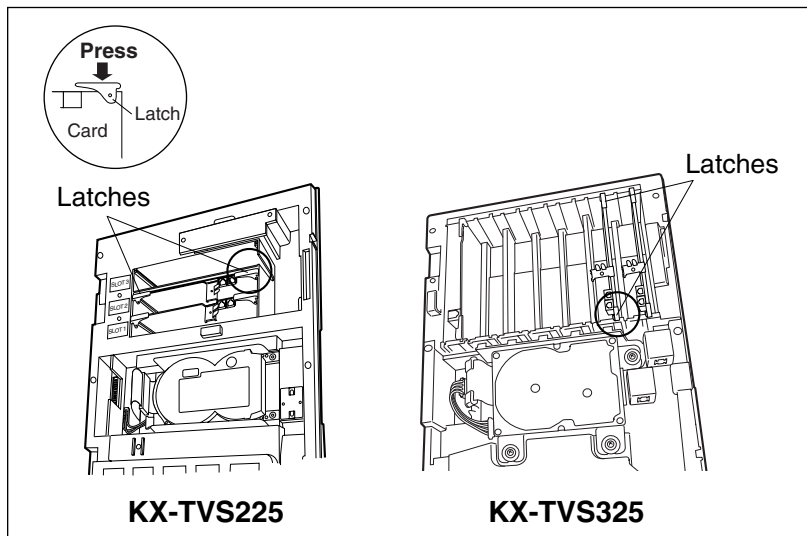

2.7 CONNECTIONS

2.7.1 Connecting to the PBX

One jack of the VPS can be connected to 1 jack of the PBX. Use a 4-conductor cable for connection with KX-T systems that use DPT Integration. Use a 2-conductor (T and R) cable for connection to all other PBXs.

4-Conductor Cable



Modular Connection

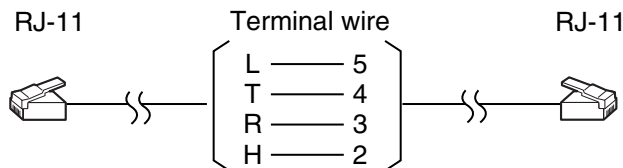
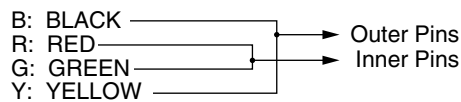

2.7.2 Opening the Ferrite Core and Cable Clip

Ferrite Core

Insert your finger into the opening of either one of the two ferrite cores and open it as shown below:

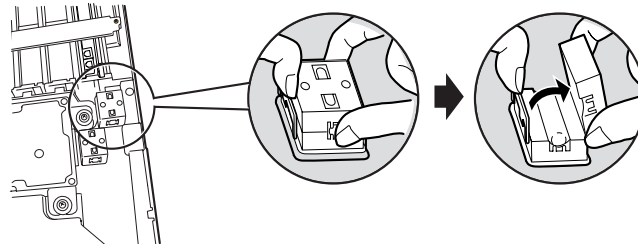

Notes

The illustration above is for the KX-TVS325 as an example; please refer to it for the KX-TVS125 and KX-TVS225.

- The KX-TVS125 and KX-TVS225 are equipped with only one ferrite core.
- The ferrite core for the KX-TVS125 and KX-TVS225 has the lock on the right side.

Cable Clip (KX-TVS325 only)

Lift the right end of the cable clip with your finger as shown below:

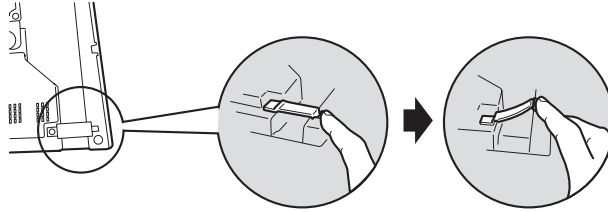

Connect a 4-conductor cable or 2-conductor cable to the VPS and run the cable through the ferrite core and under the cable clip (see the following sections). Close the ferrite core and the cable clip.

2.7.3 Modular Plug Connection

Insert the modular plug of the telephone cord into the modular jack on the port card. Guide the telephone cord through a ferrite core and under the cable clip. Close the ferrite core and the cable clip.

Telephone Line Modular Jacks

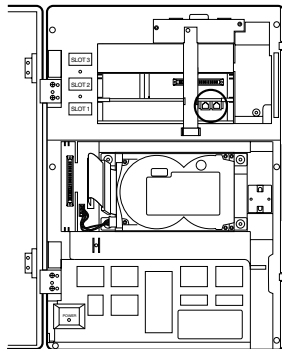

KX-TVS125

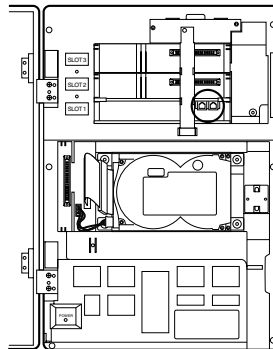

KX-TVS225

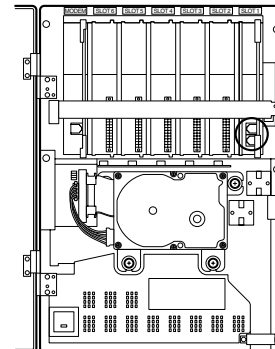

KX-TVS325

2.7.4 Port Cards

There are 2 types of port expansion cards (see 2.6 INSTALLING PORT EXPANSION CARDS: KX-TVS102 OR KX-TVS204).

- Four Digital ports expansion card (KX-TVS204)
- Two Digital/Analog ports expansion card (KX-TVS102)

One KX-TVS204 card (2 jacks) can support 4 VPS ports using the DPT Integration mode. The KX-TVS204 card does not function with any other integration mode (Inband Integration, None).

Note

The KX-TVS204 card can not be installed in SLOT 2 of the KX-TVS125.

One KX-TVS102 (2 jacks) can support 2 VPS ports under either Inband or DPT Integration.

Table 2-3 The Number of Ports VPS Cards Can Support

Card Type	Integration Mode	
	DPT	Inband/None
KX-TVS204	4	Not available
KX-TVS102	2	2

Note

Only 1 integration mode among DPT, Inband and None can be used at a time.

Expansion Capabilities for the KX-TVS125

One KX-TVS204 card is installed in SLOT 1 of the KX-TVS125 prior to factory shipment. You can install an additional KX-TVS102 card in SLOT 2 for expansion. (Only the KX-TVS102 can be installed in SLOT 2 of the KX-TVS125.) The KX-TVS125 can support a maximum of 6 VPS ports.

When using a KX-TVS102 card, only the first 2 ports of the 4 available ports can be used. For example, when you mount the KX-TVS204 in SLOT 1, the VPS supports ports 1-4. When the KX-TVS102 is installed in SLOT 1, the VPS is only able to support ports 1 and 2.

When installing, ensure that the proper number of VPS ports have been set up and correspond to the port parameters established by the System Administrator.

See Table 2-4 Card Configuration Examples (DPT Integration)—KX-TVS125 for card configuration examples, and the available number of ports in each case.

Table 2-4 Card Configuration Examples (DPT Integration)—KX-TVS125

Example No.	SLOT 2 (Port 5, 6)	SLOT 1 (Port 1-4)	Total Number of Ports
1	TVS102 (Port 5, 6)	TVS102 (Port 1, 2)	4
2		TVS102 (Port 1, 2)	2
3	TVS102 (Port 5, 6)	TVS204 (Port 1-4)	6
4		TVS204 (Port 1-4)	4

Expansion Capabilities for the KX-TVS225 and KX-TVS325

There are 3 SLOTS available in the KX-TVS225, and 6 SLOTS available in the KX-TVS325. Four VPS ports are assigned to each SLOT. The KX-TVS225 can support a maximum of 12 VPS ports; the KX-TVS325, 24.

When using a KX-TVS102 card, only the first 2 ports of the 4 available ports can be used. For example, when you mount the KX-TVS204 in SLOT 1, the VPS supports ports 1-4. When the KX-TVS102 is installed in SLOT 1, the VPS is only able to support ports 1 and 2. When installing, ensure that the proper number of VPS ports have been set up and correspond to the port parameters established by the System Administrator.

See Table 2-5 Card Configuration Examples (DPT Integration)—KX-TVS225 or Table 2-6 Card Configuration Examples (DPT Integration)—KX-TVS325 for card configuration examples, and the available number of ports in each case.

Table 2-5 Card Configuration Examples (DPT Integration)—KX-TVS225

Example No.	SLOT 3 (Port 9-12)	SLOT 2 (Port 5-8)	SLOT 1 (Port 1-4)	Total Number of Ports
1	TVS204 (Port 9-12)	TVS204 (Port 5-8)	TVS204 (Port 1-4)	12
2	TVS102 (Port 9, 10)	TVS102 (Port 5, 6)	TVS102 (Port 1, 2)	6
3		TVS102 (Port 5, 6)	TVS204 (Port 1-4)	6
4	TVS102 (Port 9, 10)	TVS102 (Port 5, 6)	TVS204 (Port 1-4)	8

Table 2-6 Card Configuration Examples (DPT Integration)—KX-TVS325

Example No.	SLOT 6 (Port 21-24)	SLOT 5 (Port 17-20)	SLOT 4 (Port 13-16)	SLOT 3 (Port 9-12)	SLOT 2 (Port 5-8)	SLOT 1 (Port 1-4)	Total Number of Ports
1	TVS204 (Port 21-24)	TVS204 (Port 17-20)	TVS204 (Port 13-16)	TVS204 (Port 9-12)	TVS204 (Port 5-8)	TVS204 (Port 1-4)	24
2	TVS102 (Port 21, 22)	TVS102 (Port 17, 18)	TVS102 (Port 13, 14)	TVS102 (Port 9, 10)	TVS102 (Port 5, 6)	TVS102 (Port 1, 2)	12
3					TVS102 (Port 5, 6)	TVS204 (Port 1-4)	6
4				TVS102 (Port 9, 10)	TVS102 (Port 5, 6)	TVS204 (Port 1-4)	8

2.7.5 Internal Modem Card (KX-TV325 only)

The Internal Modem Card allows programming and maintenance of the KX-TV325 from a remote location.

Insert the telephone line from the Central Office into the modular jack on the internal modem card. Guide the telephone cord through either one of the two ferrite cores and under the cable clip. Close the ferrite core and the cable clip.

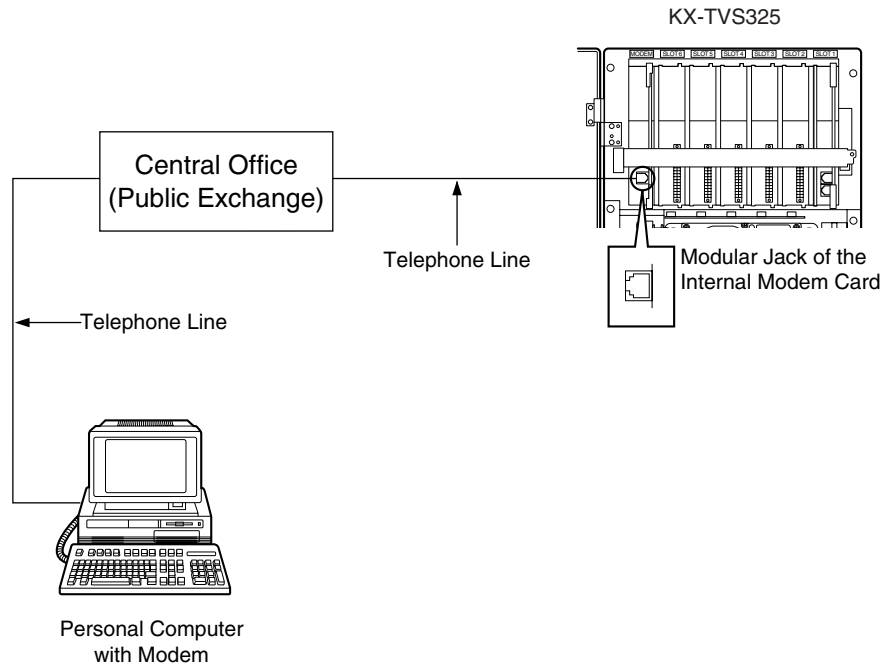

Notes

- The internal modem can also be connected to the Central Office via your PBX. This will save you a CO line. However, the actual data transfer rate of the internal modem (maximum 33600 bps) will be subject to the throughput limitations of the PBX.
- If you start the VPS with the internal modem card properly installed, the following message will appear on the screen: "Modem Card Initialization Completed". If "Modem Card Initialization Failed" appears instead, retry after ensuring that the modem card has been properly installed.

2.8 TERMINAL CONNECTION

2.8.1 Requirements for Connecting Programming Terminal

The programming terminal must be connected with a serial cable with an RS-232C connector at the RS-232C port. This must be a null modem cable. This enables system administration (system setup, mailbox setup, and system diagnosis) to be performed.

Communication parameters of the VPS have been set to the following values at the factory:

Table 2-7 COMMUNICATION PARAMETERS

Baud Rate:	9600 bps
Word Bit Length:	8 Bits
Parity:	None
Stop Bit Length:	1 Bit

2.8.2 Connecting the RS-232C Cable

RECOMMENDED:

Before connecting the cable, switch off the power on both the data terminal and the VPS.

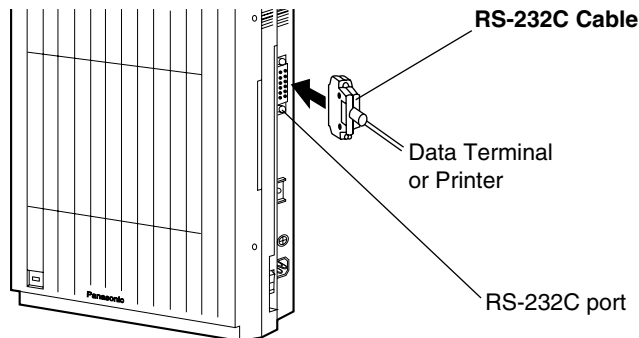

Insert the RS-232C cable into the VPS with the connector indicating the same direction.

The cable must be shielded and no longer than 2 m {6.5 feet}.

Standard IBM® 25-Pin Connection

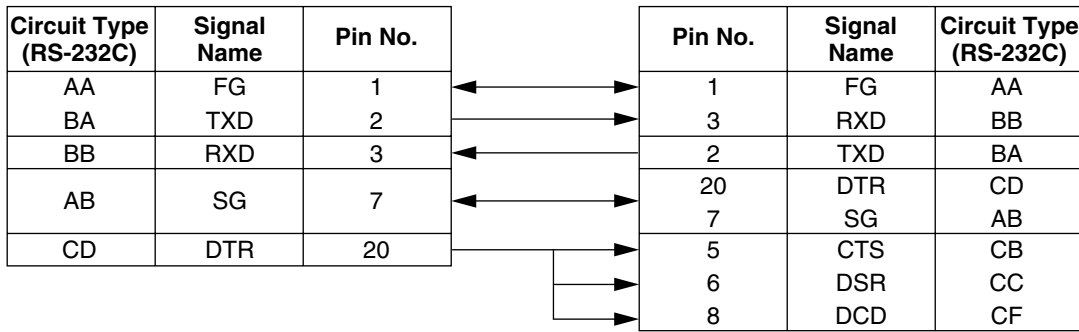

Table 2-8 Pin Configuration of the RS-232C

Pin Number	Signal Name		Circuit Type	
			RS-232C	CCITT
1	FG	Frame Ground	AA	101
2	TXD	Transmitted Data	BA	103
3	RXD	Received Data	BB	104
4	RTS	Request To Send	CA	105
6	DSR	Data Set Ready	CC	107
7	SG	Signal Ground	AB	102
8	DCD	Data Carrier Detect	CF	109
20	DTR	Data Terminal Ready	CD	108.2

2.8.3 RS-232C Signals

Frame Ground (FG)

Connects an external ground to the unit frame, usually the ground pin of the AC power cord.

Transmitted Data (TXD)—output

Conveys signals from the unit to the terminal/printer. A "mark" condition is held unless data or BREAK signals are being transmitted.

Received Data (RXD)—input

Conveys signals from the terminal/printer to the unit.

Request To Send (RTS)—output

This lead is held on whenever DSR is on.

Signal Ground (SG)

Connects to the DC ground of the unit for all interface signals.

Data Terminal Ready (DTR)—output

This signal line is turned on by the unit to indicate that it is RS-232C on-line. Circuit DTR ON does not indicate that communication has been established with the terminal/printer. It is switched off when the unit is RS-232C off-line.

Section 3

***INTEGRATING THE VPS WITH PANASONIC
KX-T PHONE SYSTEMS***

3.1 GUIDELINES FOR INTEGRATION

3.1.1 DPT or Inband Signaling?

There are 2 types of integration available on the VPS: Inband Signaling and DPT. The VPS used with any other brand of telephone equipment requires inband equipment.

KX-TD/KX-TDA/KX-TAW series PBXs that can use DPT Integration are:

- KX-TD500 Version Q171AA or higher
- KX-TD308 Version P871F or higher
- KX-TD816 Version P301O or higher
- KX-TD1232 Version P231U or higher
- KX-TDA series Version 1.0 or higher
- KX-TAW series Version 1.0 or higher

Likewise, the KX-TA1232 can also use DPT Integration:

- KX-TA1232 Version P831AA or higher (all versions)

Notes

- To the VPS, the KX-TA1232 looks identical to the KX-TD1232.
- Depending on the model and/or the software version of the connected PBX, you may not be able to utilize some of the features available only with DPT Integration (see 4.1.1 Why DPT Integration is Important). For more information, call National Parts Center at 1-800-833-9626.

3.1.2 Why Integration is Important

The VPS works well with most PBXs because its connections are made through a standard single-line (tip/ring) telephone interface. However, the VPS operation depends on the capabilities and features provided by the PBX; its performance will vary when connected with different PBX systems. For example, Follow-on (or Called Party) ID is a feature of the PBX. If the PBX does not have this feature, the VPS cannot transfer calls directly to the correct mailbox and play the Busy or No Answer greeting for that mailbox.

3.1.3 How the VPS and the PBX Communicate

To the PBX, the VPS looks like SLT sets. The PBX thinks that the VPS is an SLT, and the VPS mimics all actions a live attendant would carry out from an SLT.

For the VPS and the PBX to communicate, proper signaling is important. Like an attendant, the VPS places calls by going off-hook and dialing numbers. It starts call transfers with a hookswitch flash to put callers on hold and then dials the extension number. By recognizing call progress tones from the PBX, the VPS decides how calls should be handled. Inband Integration allows the PBX to send certain digits (touchtone) to the VPS, allowing it to recognize the status of the extension and take the appropriate action.

Table 3-1 VPS/PBX COMMUNICATION

<u>PBX to VPS</u>	<u>VPS to PBX</u>
Call Progress Tones	SLT Signals
<ul style="list-style-type: none"> • ringback • busy • reorder 	<ul style="list-style-type: none"> • on/off hook • hookswitch flash • touchtones
Touchtones	

The VPS must also have access to certain PBX features. For example, if the VPS takes a message, one way it can notify the mailbox owner is by dialing the PBX’s Message-Waiting-Lamp-On code. Once new messages are retrieved, the VPS dials the Message-Waiting-Lamp-Off code for that same mailbox owner.

3.1.4 PBX Requirements for Integration

The PBX must have certain capabilities and features to work with the VPS. (Although this section includes tests to help you evaluate the PBX, it may be necessary to refer to the PBX’s documentation for detailed capability and feature descriptions.)

Single Line (Tip/Ring) Port Circuits

The VPS can only be connected to a PBX that supports SLT sets. Some PBXs need an OPX card to provide this connection. **However, some OPX cards do not provide all the capabilities listed in this section.**

Following are the minimum current and voltages that the PBX must supply:

Table 3-2

Minimum Loop Current	20 mA
Minimum Line Voltage	7 V DC
Minimum Ringing Voltage	40 V AC

Station to Station Touchtone Signaling

For system users to access VPS services and features, they must be able to send touchtones from their telephones to the VPS port. As a general rule, SLT sets can perform station-to-station touchtone signaling; however, many proprietary telephones cannot. Some PBXs need to be programmed to make proprietary sets use touchtone signaling.

If the PBX does not provide station-to-station touchtone signaling, VPS services and features will be limited.

TEST: Call an SLT extension from the telephone in question. When the call is answered, see if the person receiving the call hears touchtones when numbers are dialed.

Message Waiting Notification from an SLT

The PBX extensions should light a lamp or receive stutter dial tone when the Message-Waiting-Lamp-On code is dialed by the VPS. The VPS functions best when the extension number of the voice mailbox owner follows the Light-On or Light-Off code. On some PBXs, however, the extension number is dialed first, followed by a hookswitch flash and then the On code. This presents a problem if the extension is answered before the VPS sends the hook-switch flash.

If the PBX does not provide message waiting notification from an SLT, the VPS can only notify mailbox owners by dialing a beeper number or user-assigned extension.

This process slows down VPS performance as it dials the beeper or extension number and waits to confirm notification. The beeper or user-assigned extension notification is meant to be used for necessity, usually for mailbox owners who are often out of the office (e.g., sales people or field representatives). The only other option, without message waiting notification, is for mailbox owners to periodically call the VPS to check for messages.

TEST: See if dialing the On code from an SLT can turn on an extension's message waiting indicator.

Screened Transfer from an SLT

The PBX must provide a screened transfer from an SLT for the VPS to function properly.

A screened transfer:

1. *Puts the caller on hold, usually with a hookswitch flash.*
2. *Dials the extension.*
3. *Checks to see if the called subscriber is in, out, or on another line, and whether or not that subscriber accepts the transfer.*
4. *Completes the transfer (by going on-hook) or returns to the caller to say that the party is busy or not available. It then gives the caller an opportunity to leave a message.*

If the PBX does not provide screened transfer from an SLT, the VPS cannot give callers the option to leave a message in a subscriber's mailbox.

TEST: Place an outside call from an SLT. See if you can set up a screened transfer to another extension. Next, try the same test with an internal call. (The VPS may have to transfer both types of calls.)

Follow-on ID or Called Party ID

When forwarding or transferring a call to the VPS, a PBX with Follow-on ID sends the mailbox number of the called subscriber to the VPS before connecting the caller. The VPS responds by playing that subscriber's personal greeting. This operation is sometimes called Call Forward to Mailbox. Without this feature, the VPS cannot immediately play the greeting when the line is busy or there is no answer and allow the caller to leave a message.

3.2 PBX PARAMETERS AND PORT SETTINGS

3.2.1 General Guidelines and Definitions

Optimal performance of the VPS/PBX system relies on proper VPS programming. There are 3 categories of hardware settings: RS-232C, Port Settings, and PBX Interface Parameters. Entering a number sets some of the parameters, while others use sequence codes.

3.2.2 RS-232C Settings

- **Baud Rate (300-38400):** Specifies the speed at which the data is transferred in bits-per-second.
- **Word Bit Length (7-8):** Defines the number of bits in each byte or character.
- **Parity (N, O, E):** Specifies the parity used for error detection.
- **Stop Bit Length (1-2):** Specifies the number of bits used to signify the end of the byte.
- **Default:** 9600, 8, N, 1

3.2.3 Port Settings

There is no need to change these in a typical installation. Only change these parameters when connecting the VPS to a PBX other than a KX-T series PBX. Each port on the VPS should match the type of signaling the PBX expects. If you need to change these settings, refer to the PBX manual or customer support office to get the correct values for these settings.

- **Flash Time—100 ms, 300 ms, 600 ms, 900 ms:**
The minimum length of time that the PBX requires to recognize a hookswitch flash. Choose the amount that is equal to or greater than the PBX's setting.
- **CPC Signal (Calling Party Control Signal)—NONE, 6.5 ms, 150 ms, 300 ms, 450 ms, 600 ms:**
The length of time allowed for the short break in loop current that is used to indicate that the caller has hung up; usually set to NONE, since most PBXs do not provide this signal to single line ports. If choosing a setting other than NONE, use an amount equal to or less than the PBX or telephone company provided CPC signal.
- **Disconnect Time—1 s-8 s:**
The length of time that the line is temporarily unavailable after a call has ended.
- **Dial Mode—Touchtone, Pulse 10 pps, Pulse 20 pps:**
The type of signaling the PBX single line port expects to receive (pps = pulses per second).

3.2.4 PBX Interface Parameters

Dialing Parameters

- **PBX Type:**
Specifies the type of PBX which is connected to the VPS.
- **Integration Mode:**
Specifies the method of integration to be used between the VPS and PBX. If PBX type is set to the Panasonic KX-T series, the Inband Signaling parameters are set automatically and should not be altered. DPT Integration is only available when a KX-TD/KX-TDA/KX-TAW series or KX-TA1232 PBX is connected and the software is upgraded.

Table 3-3 SEQUENCE CODES

D	Disconnect
F	Hookswitch Flash
R	Ring Detection
S	Silence Detection
T	Dial Tone Detection
W	Wait for 1 Second
X	Dial Extension
A	Answer
0-9, *, #	Touchtone Digits

- **Operator Transfer Sequence:**
Tells the VPS how to transfer a call to the operator.
Example: FTX [hookswitch flash—dial tone—dial (operator) extn.]
- **Extension Transfer Sequence:**
Tells the VPS how to transfer a call to an extension.
Example: FTX [hookswitch flash—dial tone—dial extn.]
- **Alternate Extension (Transfer Sequence):**
Tells the VPS how to transfer a call to an extension that belongs to the "Alternate Extension Group". This is useful for extensions that need a special transfer procedure (i.e., blind transfer) such as modem extensions.
Example: FTXD [hookswitch flash—dial tone—dial extn.—hang up]
- **Reconnect Sequence on Busy:**
Tells the VPS how to return to the caller if the called extension is busy. PBXs differ in how they handle this function. Test from an SLT to determine the sequence.
- **Reconnect Sequence on No Answer:**
Tells the VPS how to return to the caller if the called extension does not answer. PBXs differ in how they handle this function. Test from an SLT to determine the sequence.
- **Reconnect Sequence on Refused Call:**
Tells the VPS how to return to the caller if the called extension's owner has enabled Call Screening to not take the call. PBXs differ in how they handle this function. Test from an SLT to determine the sequence.

- **Light On Sequence for Message Waiting Lamp:**
This is the dialing sequence that the VPS must use to turn on a message waiting lamp at an extension.
- **Light Off Sequence for Message Waiting Lamp:**
This is the dialing sequence that the VPS must use to turn off a message waiting lamp at an extension.
- **Call Waiting Sequence:**
This sequence is carried out by the VPS to perform call waiting when the called extension is busy. PBXs differ in how they handle this function. Test from an SLT to determine the sequence.
- **Release Sequence for Call Waiting:**
This sequence is carried out by the VPS to release call waiting. PBXs differ in how they handle this function. Test from an SLT to determine the sequence.

Inband Signaling

These parameters are used when the Integration Mode is set to Inband. If the PBX type is set to a KX-T series system, these parameters will be automatically set. If another type PBX is used, check that system's installation manual for settings.

Table 3-4

Code (default)	Call State	Sent to the Voice Mail Port When...
1	Ringback Tone	The extension dialed is ringing.
2	Busy Tone	The extension dialed is busy.
3	Reorder Tone	An invalid extension number is dialed or the call is inadvertently connected to another Voice Mail port (also heard when no touchtone receiver is available to the Voice Mail extension).
4	DND	The extension dialed has set DND feature (Do Not Disturb).
5	Answer	The extension dialed is answered.
6	Forwarded to Voice Mail (Ringing)	The extension dialed is forwarded to Voice Mail and another Voice Mail port is able to answer. (This lets the first Voice Mail port, usually an Auto Attendant, send the call to the other Voice Mail port.)
7	Forwarded to Voice Mail (Busy)	The extension dialed is forwarded to Voice Mail and no other Voice Mail ports are available to accept the call. (This signals the Voice Mail port [usually Auto-Attendant] to let the caller to leave a message.)
8	Forwarded to Extn.	The extension dialed is forwarded to another non-Voice Mail extension.
9	Confirmation Tone	The Message Waiting Lamp On or Message Waiting Lamp Off code is dialed successfully.
#9	Disconnect	The caller disconnects. The central office must set a CPC signal to the PBX line for this signal to work for outside calls.

Digit Translation Table Parameters

These parameters allow PBXs that have a fixed Follow-on ID sequence to be used with the VPS. For example, a Follow-on ID sequence of [* * * 1001] can be changed to [#61001] by using these parameters.

- **Inter-Digit Time-Out:**
This parameter defines the interval of incoming signals (Follow-on ID) from the PBX to the VPS. The Digit Translation Table applies the digits received within this time to translation.
- **Input-Output (up to 8 alphanumeric characters):**
When the system receives digits within the inter-digit time, it checks them against the input table. If they are found, the system utilizes the output digits in their place.

Transfer to Outside Parameters

These parameters specify how the VPS will transfer calls to outside lines from the following services: Custom Service, Call Transfer Service, Personal Custom Service, Caller ID Callback.

[Outside Transfer Sequence]

- **Call Transfer to Outside Sequence:**
This parameter specifies the sequence the VPS uses to transfer calls to outside lines.
- **Call Transfer to Outside Reconnect Sequence on Busy:**
This parameter specifies the sequence the VPS uses to reconnect the line when the transferred party is busy.
- **Call Transfer to Outside Reconnect Sequence on No Answer:**
This parameter specifies the sequence the VPS uses to reconnect the line when the transferred party does not answer.
- **EFA Transfer Sequence:**
This parameter specifies the sequence the VPS uses to transfer calls to outside lines using EFA (External Feature Access).
- **EFA Transfer Reconnect Sequence on Busy:**
This parameter specifies the sequence the VPS uses to reconnect the line when the party transferred with EFA (External Feature Access) is busy.
- **EFA Transfer Reconnect Sequence on No Answer:**
This parameter specifies the sequence the VPS uses to reconnect the line when the party transferred with EFA (External Feature Access) does not answer.
- **Outside Transfer Answer Mode:**
This parameter specifies the answering method the VPS uses to recognize whether the destination party has answered the transferred outside call.

[Trunk Group]

- **EFA Transfer:**
This parameter specifies whether or not the VPS uses EFA (External Feature Access) when transferring an incoming outside call to an outside line.
- **Caller ID Callback:**
This parameter specifies whether or not the VPS allows a subscriber to call back the party who left a message in his mailbox with the Caller ID number sent from the PBX.
- **Outside Line Access Sequence for Caller ID Callback:**
This parameter specifies the sequence of outside line access codes for Caller ID Callback.
This parameter is available when the VPS executes Caller ID Callback without using EFA.

- **Caller ID Modify Table (1-4):**
This parameter specifies the number of the Caller ID Modify Table that is used when the VPS converts the Caller ID Number sent from the PBX to the VPS.

[Caller ID Modify Table]

- **Local Area Code/International Code:**
This parameter specifies the local area/international codes that are used when the VPS converts the Caller ID Number sent from the PBX to the VPS.
- **Remove Digits (0-9):**
This parameter specifies the number of digits to be deleted from the telephone number (sent from the PBX) to make up a telephone number for a local area/international/long distance call. Digits are removed from the beginning of the received digits.
- **Additional Dial:**
This parameter specifies the number to be added to the telephone number (sent from the PBX) to make up a telephone number for a local area/international/long distance call. The number is added to the beginning of the received digits.

VPS Port Parameters

These parameters specify the extension numbers of VPS ports.

- **Extension Number of VPS Port 1-24:**
This parameter specifies the extension number of each VPS port. The maximum number of ports depends on the VPS model.

Note

Extension numbers of the VPS ports will automatically be assigned when: (1) Auto Configuration is executed, or (2) PBX type has been changed.

The remainder of this section consists of step-by-step guides for software verification and programming of the recommended Panasonic PBX systems. If you (the dealer) have any problem as you go through this section, please call 1-800-211-PANA(7262).

3.3 CONNECTING THE VPS WITH PANASONIC KX-T SERIES PBXs

3.3.1 VPS Programming for Inband Integration

Set parameters from the System Administration Terminal. The table below lists recommended parameters for Panasonic KX-T series PBXs.

Table 3-5

PBX Type	Other Manufacturers	T308/ T616	T1232/ TA624	T96	T336	TD816/ TD1232/ TA1232/ TD308	TD500	TDA/ TAW series
Integration Mode	None	None	None	None	None	None	None	None
	Inband		Inband	Inband	Inband	Inband	Inband	Inband
Operator Transfer Sequence	FX (A)	FTX (A)	FTX (A)	FTX (A)	FTX (A)	FTX (A)	FTX (A)	FTX (A)
Extension Transfer Sequence	FX (A)	FTX (A)	FTX (A)	FTX (A)	FTX (A)	FTX (A)	FTX (A)	FTX (A)
Alternate Extension Transfer Sequence	FX (A)	FTX (A)	FTX (A)	FTX (A)	FTX (A)	FTX (A)	FTX (A)	FTX (A)
Reconnect Sequence on Busy	FWW	FWW	FWW	FWW	FWW	FWW	FWW	FWW
Reconnect Sequence on No Answer	FWW	FWW	FWW	FWW	FWW	FWW	FWW	FWW
Reconnect Sequence on Refuse Call	FWW	FWW	FWW	FWW	FWW	FWW	FWW	FWW
Light-On Sequence for Message Waiting Lamp	*	N/A	T701X#	T#91X	T*9X	T701X	T701X	T*701X
Light-Off Sequence for Message Waiting Lamp	*	N/A	T702X#	T#90X	T#9X	T700X	T700X	T*700X
Call Waiting Sequence	*	N/A	1	N/A	N/A	1	1	1

Table 3-5

PBX Type	Other Manufacturers	T308/ T616	T1232/ TA624	T96	T336	TD816/ TD1232/ TA1232/ TD308	TD500	TDA/ TAW series
Release Sequence for Call Waiting	*	N/A	F	N/A	N/A	F	F	F

* Check with manufacturer.

N/A Not Available

(A) Adding "A" for "answer" to the operator and extension transfer eliminates the message: "You have a call" when the AA transfers a call. The VPS disconnects after line is answered. Adding "D" for "disconnect" creates a blind transfer.

3.3.2 KX-TA624 Programming for Inband Integration via the Manager's Extension

Note

If your PBX is the KX-TA1232, please refer to the procedure described in 3.3.4 KX-TD816, KX-TD1232, KX-TA1232 and KX-TD308 Programming for Inband Integration via the Manager's Extension or 3.3.5 KX-TD816, KX-TD1232, and KX-TA1232 Programming for Inband Integration via the Operating and Maintenance Tool for programming.

1. Enable System Program [102] for each extension connected to the VPS. Jack 07, or jacks 07 and 08 can be assigned for the VPS as the Voice Mail port.

This parameter is used to tell the KX-TA624 which extensions are connected to the VPS. Ports with this parameter enabled can receive Follow-on ID and touchtone call status Signaling (busy, answered, disconnect, etc.) if the Voice Mail integration and Touchtone Integration features are also enabled.

2. Enable System Program [103] to turn on Touchtone Integration. On extensions with the Voice Mail port parameter enabled, the KX-TA624 can send codes (touchtones) to indicate call states; this increases VPS efficiency. Codes apply to all transferred calls; outside calls only indicate disconnect (provided the KX-TA624 is programmed for CPC Detection, and the Central Office sends the CPC signal). Refer to the Table 3-3 SEQUENCE CODES in Section 3.2.4 PBX Interface Parameters.
3. Put all extensions connected to the VPS into 1 extension group using System Program [600].

Reserve this extension group for these extensions! Do not mix other extensions into this group.

4. Enable hunting for the VPS extension groups using System Program [100].

5. Set the hunting type for the VPS extension groups to circular using System Program [101].
6. At every VPS extension, temporarily connect an SLT or butt set, go off-hook and dial 7301# to turn on Data Line Security. This prevents the KX-TA624 from sending Executive Override or Call Waiting tones to these extensions. We recommend that all Voice Mail port extensions have this feature enabled to avoid interruption of recording.
7. Select the appropriate outside (CO) line feature settings depending on how your customer plans to use the VPS: A) to answer all incoming calls, B) as an operator backup, or C) to only answer calls not answered by user extensions.

Recommended outside (CO) line feature settings:

- a) If the VPS is answering all incoming calls:
 - Outside (CO) Line Mode**—Use System Programs [414] (Day Mode), [415] (Night Mode), [416] (Lunch Mode) to set this parameter. Program all lines DIL to the first extension of the Voice Mail hunt group. The KX-TA624 will allow incoming outside calls to hunt only if the outside (CO) lines are DIL to the first port of the hunt group. Lines programmed as "Normal" do not hunt.
- b) If the VPS is only answering calls not answered by the operator (Operator Backup):
 - Flexible Ringing Assignment**—For each outside (CO) line, use System Programs [408] (Day Mode), [409] (Night Mode) and [410] (Lunch Mode) to enable ringing at the operator's extension (jack).
 - Delayed Ringing Assignment**—To give the operator time to answer the call before the VPS picks up, we recommend setting the delay to a few seconds for each extension connected to the VPS. Use System Programs [411] (Day Mode), [412] (Night Mode) and [413] (Lunch Mode).
 - Outside (CO) Line Mode**—Set the mode for each outside (CO) line to "Normal". Use System Programs [414] (Day Mode), [415] (Night Mode) and [416] (Lunch Mode) to set this parameter.
- c) If the VPS is only answering calls not answered by user extensions:
 - Flexible Ringing Assignment**—For each outside (CO) line, use System Programs [408] (Day Mode), [409] (Night Mode) and [410] (Lunch Mode) to enable ringing on every extension (jack) that you want to have ring.
 - Delayed Ringing Assignment**—To give users time to answer the call before the VPS picks up, we recommend setting the delay to a few seconds for each extension connected to the VPS. Use System Programs [411] (Day Mode), [412] (Night Mode) and [413] (Lunch Mode).
 - Outside (CO) Line Mode**—Set the mode for each outside (CO) line to "Normal". Use System Programs [414] (Day Mode), [415] (Night Mode) and [416] (Lunch Mode) to set this parameter.

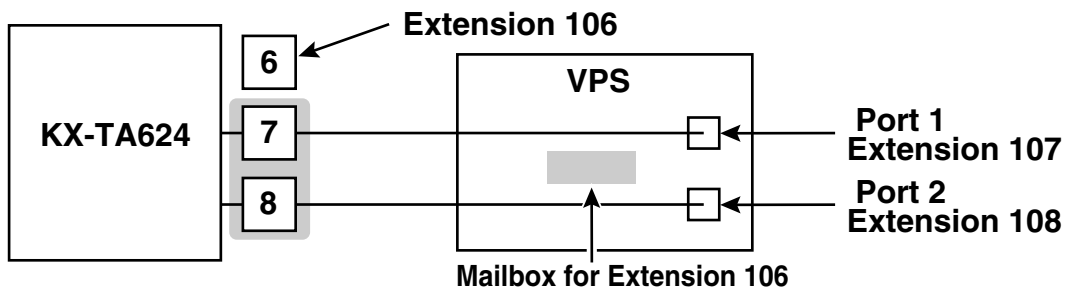

3.3.3 KX-TD500 Programming for Inband Integration

Whenever possible, we recommend that you use DPT Integration. However, in some cases, this is not possible. In the following situations, you need to use Inband Integration:

- Your PBX is a third-party telephone system.
- You have a KX-TD500, but all the extension cards are analog types.
- You have a KX-TD500, but the DHLC/DLC cards are ancient versions (therefore, cannot support DPT Integration).

1. Assignment of the extension card to be connected to the VPS
 - a) Go to the "1-1 Slot Assignment" screen.
 - b) Assign the slot card type to be installed to "DHLC", "HLC", "SLC", "ESLC", or "SLC-M" SLT interface supports.
 - c) Click "Apply" to save the slot card type assignment.
 - d) Set "Card Status" to "INS".

Screen output:

The screenshot shows the '1-1 Slot Assignment' window with three columns: Basic Shelf, Expansion Shelf 1, and Expansion Shelf 2. Each column has a table with Slot No., Card Type, and Status.

Basic Shelf			Expansion Shelf 1			Expansion Shelf 2		
Slot No.	Card Type	Status	Card Type	Status	Card Type	Status	Card Type	Status
1	DHLC	INS						
2								
3								
4	DHLC	INS						
5								
6	ELCOT	INS						
7	DLC	INS						
8								
9								
10								
11								
12								
13	CPU							
14	TSW							

At the bottom of the window, there is a dropdown menu labeled '1-1 Slot Assignment', and 'Close' and 'Help' buttons.

2. Assignment of the extension ports to be connected to the VPS
 - a) Go to the "1-3 Extension Port Assignment" screen.
 - b) Assign "Attribute" of the port to be connected to "TEL" (default).
 - c) Assign "DN" for the port (click "DN Refer" to check the available directory numbers).

Note

This program allows you to assign an extension number to each Voice Mail port. To reach the Voice Mail system, users dial these extension numbers.

- d) Assign "Extension Group No." for the port.

Note

Specify the extension group number (126 or 127 by default) to which VM or AA extension groups have been assigned. Group numbers 1 to 128 are available to the VPS through additional programming.

- e) Click "Apply" to save the changed data.
- f) Set "Port Status" to "INS".

Screen output:

Port No.	Attribute	Tel. Type	DN	Group No.	Parallel / XDP	Status
1	TEL	T7235	1001	128	Parallel	INS
2	TEL	T7420	1002	1	Parallel	INS
3	TEL	T7235	1003	1	Parallel	INS
4	TEL	T7436	1004	1	Parallel	INS
5	TEL	Unknown	1005	126	Parallel	INS
6	TEL	Unknown	1006	126	Parallel	INS
7	TEL	Unknown	1007	126	Parallel	INS
8	TEL	T7230	1008	1	Parallel	INS

Card No. 101:DHLC

1-3 Extension Port Assignment

OK Apply Cancel Help

3. Assignment of the extension line to be connected to the VPS
 - a) Go to the "4-2 Extension Line" screen.
 - b) Set "Data Line Mode" to "Yes".
 - c) Click "Apply" to save the changed data.

Note

This program prevents the VM port from being interrupted by "Call Waiting", "Hold Recall", and "Executive Busy Override" features during a call.

Screen output:

The screenshot shows the '4-2 Extension Line' configuration window with the following settings:

- Card No.: 101:DHLC
- Port No.: 5
- DN: 1005
- Group No.: 126
- Mailbox No.: 1005
- Initial Display Selection: Caller ID
- COS No. Primary: 1, Secondary: 1
- Preferred Line: Outgoing: Prime Line-ICM/PDN, Incoming: Ringing Line
- LCS Setting: Status: Inactive, Operation Mode: Hands-free, Recording Mode: Stop Rec
- JOG Dial Speed: Normal
- CLIP Number: Public, Private
- Data Line Mode: Yes
- Call Waiting Tone Type: Tone 1
- Language: English
- Call Log Incoming: Overwrite Mode: Yes

4. Settings for the trunk (CO line) features

Select the appropriate trunk (CO line) feature settings depending on how your customer plans to use the VPS.

- The VPS answers all incoming outside calls promptly.
Go to [Recommended Settings (1)].
- The VPS answers when the operator does not take the call after a specified number of rings.
Go to [Recommended Settings (2)].
- The VPS answers when an extension user does not take the call after a specified number of rings.
Go to [Recommended Settings (3)].

[Recommended Settings (1)]

If the VPS is answering all incoming outside calls:

a) Assignment of DIL 1:1 line

- 1) Go to the "4-1 Trunk Line" screen.
- 2) Assign "Destination Day/Night/Lunch/Break" for each trunk (CO line) to a specific extension number (VPS port).
- 3) Click "Apply" to save the changed data.

Note

Specify the FDN for the extension group to which VM or AA has been assigned. In order to utilize the Caller ID features, you must Set "Caller ID" to "Enable".

Screen output:

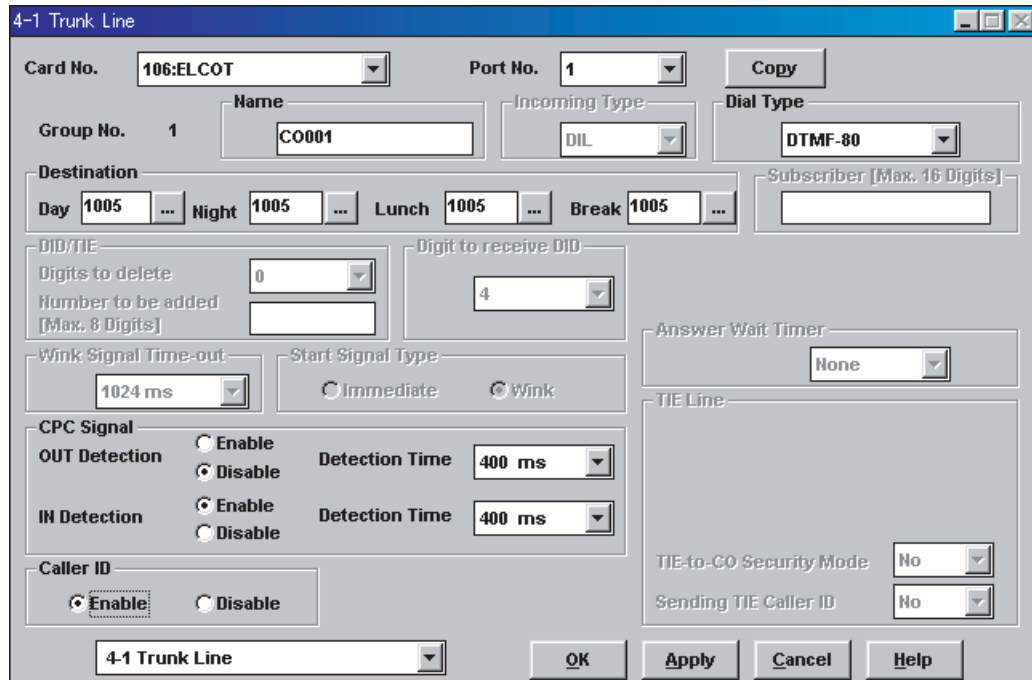

[Recommended Settings (2)]

If the VPS is only answering incoming outside calls not answered by the Operator (Operator backup):

- a) Assignment of DIL 1:1 line
 - 1) Go to the "4-1 Trunk Line" screen.
 - 2) Assign "Destination Day/Night/Lunch/Break" for each trunk (CO line) to a specific extension number.
 - 3) Click "Apply" to save the changed data.

Note

Specify the FDN for the extension group to which Operator has been assigned.

Screen output:

The screenshot displays the '4-1 Trunk Line' configuration interface. Key fields include:

- Card No.:** 106:ELCOT
- Port No.:** 1
- Group No.:** 1
- Name:** CO001
- Incoming Type:** DIL
- Dial Type:** DTMF-80
- Destination:** Day, Night, Lunch, and Break are all set to 1001.
- DID/TIE:** Digits to delete: 0; Digit to receive DID: 4.
- Wink Signal Time-out:** 1024 ms
- Start Signal Type:** Wink (selected)
- CPC Signal:** OUT Detection: Disable (400 ms); IN Detection: Enable (400 ms)
- Caller ID:** Enable (selected)
- TIE Line:** TIE-to-CO Security Mode: No; Sending TIE Caller ID: No

- b) Assignment of IRNA (Intercept Routing No Answer) destination:
- 1) Go to the "3-1 Trunk Group" screen.
 - 2) Assign "Intercept Destination Day/Night" for the trunk (CO line) group.
 - 3) Click "Apply" to save the changed data.

Note

Specify the FDN for the extension group to which VM or AA has been assigned.

Screen output:

The screenshot shows a configuration window titled "3-1 Trunk Group". At the top left, "Group No." is set to "1" with a "Copy" button next to it. The "Intercept Destination" section has "Day" and "Night" both set to "1005". "Pause Time before Flash Signal" is "512 ms" and "Max. Dial No. after EFA Signal" is "0". "Line Hunting Order" is "Normal", "Tenant No." is "1", and "Flash Time" is "600 ms". "Disconnecting Time" and "Pause Time" are both "1.5 s". "PBX Access Code" has four empty input fields. "Numbering Plan ID" has "Public" and "Private" columns with "Outgoing" and "Incoming" rows, all set to "Default". "PBX Dial Tone" and "PBX Ringback Tone" are both set to "Disable". "Type of Number" also has "Public" and "Private" columns with "Outgoing" and "Incoming" rows, all set to "Default". At the bottom right, there are checkboxes for "Cyclic Signal Detection", "Continuous Signal Detection", and "Silence Detection", all of which are checked. At the bottom, there are buttons for "OK", "Apply", "Cancel", and "Help".

- c) Assignment of IRNA (Intercept Routing No Answer) timer:
- 1) Go to the "2-4 System Timer 1/2" screen.
 - 2) Assign "Intercept Time" parameter.
 - 3) Click "Apply" to save the changed data.

Note

This parameter tells the KX-TD500 how long to let a call ring at an extension before forwarding (redirecting).

Screen output:

The screenshot shows a configuration window titled "2-4 System Timer 1/2". It contains several input fields for different timer parameters:

Parameter	Value	Unit
Hold Recall Time (0-240 s)	30	s
Transfer Recall Time (0-48 rings)	12	ring(s)
Pickup Dial Waiting Time (1-5 s)	1	s
Call Duration Count Start Time (0-60 s)	0	s
First Digit Time (5-120 s)	10	s
Inter-digit Time (1-30 s)	5	s
Intercept Time (1-48 rings)	12	ring(s)
Call Forwarding - No Answer Time (1-12 rings)	3	ring(s)
Extension-to-CO line Call Duration Time (1-64 min)	10	min
CO-to-CO Line Call Duration Time (1-64 min)	10	min
Door Opener Timer (0-10 s)	5	s

At the bottom of the window, there is a dropdown menu showing "2-4 System Timer 1/2" and four buttons: "OK", "Apply", "Cancel", and "Help".

[Recommended Settings (3)]

If the VPS is only answering incoming outside calls not answered by user extensions:

- a) Assignment of DIL 1:1 line
 - 1) Go to the "4-1 Trunk Line" screen.
 - 2) Assign "Destination Day/Night/Lunch/Break" for each trunk (CO line) to a specific extension number.
 - 3) Click "Apply" to save the changed data.

Screen output:

The screenshot shows the '4-1 Trunk Line' configuration window. The fields are as follows:

- Card No.: 106:ELCOT
- Port No.: 1
- Group No.: 1
- Name: CO001
- Incoming Type: DIL
- Dial Type: DTMF-80
- Destination: Day 1002, Night 1002, Lunch 1002, Break 1002
- DID/TIE: Digits to delete: 0, Digit to receive DID: 4
- Wink Signal Time-out: 1024 ms
- Start Signal Type: Wink
- CPC Signal:
 - OUT Detection: Disable (400 ms)
 - IN Detection: Disable (400 ms)
- Caller ID: Enable
- Answer Wait Timer: None
- TIE Line: (Empty)
- TIE-to-CO Security Mode: No
- Sending TIE Caller ID: No

- b) Assignment of IRNA (Intercept Routing No Answer) destination:
- 1) Go to the "3-1 Trunk Group" screen.
 - 2) Assign "Intercept Destination Day/Night" for the trunk (CO line) group.
 - 3) Click "Apply" to save the changed data.

Note

Specify the FDN for the extension group to which VM or AA has been assigned.

Screen output:

The screenshot shows the '3-1 Trunk Group' configuration window. The window title is '3-1 Trunk Group'. The interface includes the following fields and controls:

- Group No.:** 1 (dropdown)
- Copy:** button
- Intercept Destination:** Day: 1005 (dropdown), Night: 1005 (dropdown)
- Pause Time before Flash:** Signal: 512 ms (dropdown)
- Max. Dial No. after EFA Signal:** 0 (dropdown)
- Line Hunting Order:** Normal (dropdown)
- Tenant No.:** 1 (dropdown)
- Flash Time:** 600 ms (dropdown)
- Disconnecting Time:** 1.5 s (dropdown)
- Pause Time:** 1.5 s (dropdown)
- PBX Access Code:** four empty text boxes
- Numbering Plan ID:** Public/Private columns with Default/Private dropdowns for Outgoing and Incoming.
- PBX Dial Tone:** Enable, Disable
- PBX Ringback Tone:** Enable, Disable
- Type of Number:** Public/Private columns with Default dropdowns for Outgoing and Incoming.
- Checkboxes:** Cyclic Signal Detection, Continuous Signal Detection, Silence Detection
- Buttons:** OK, Apply, Cancel, Help
- Dropdown:** 3-1 Trunk Group

- c) Assignment of IRNA (Intercept Routing No Answer) timer:
- 1) Go to the "2-4 System Timer 1/2" screen.
 - 2) Assign "Intercept Time" parameter.
 - 3) Click "Apply" to save the changed data.

Note

This parameter tells the KX-TD500 how long to let a call ring at an extension before forwarding (redirecting).

Screen output:

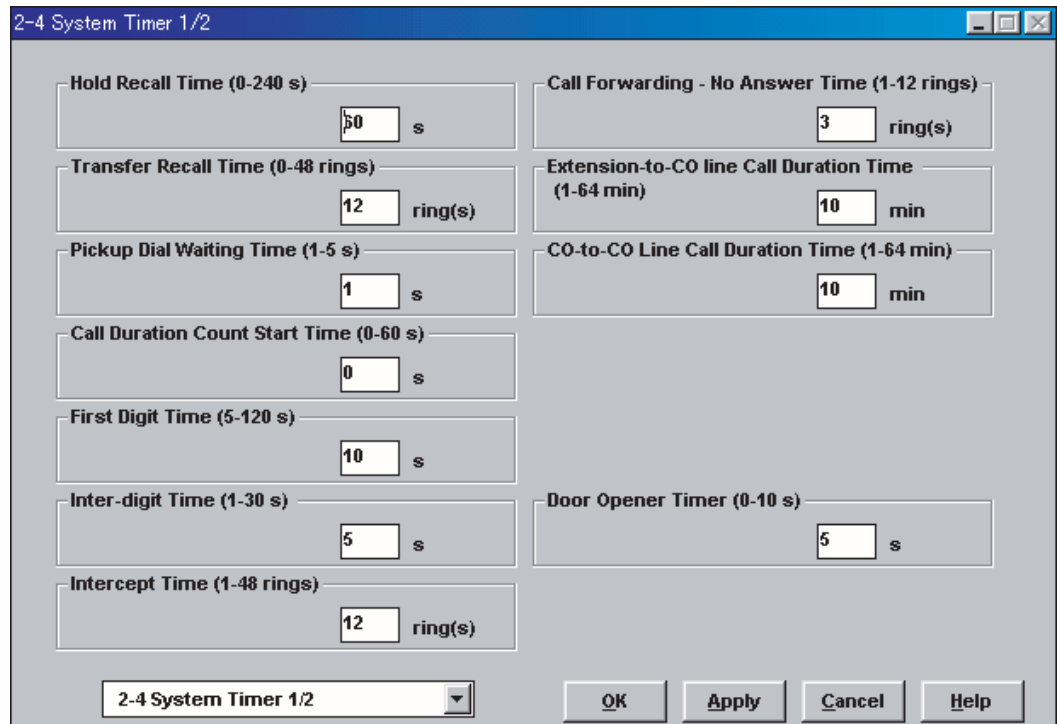

3.3.4 KX-TD816, KX-TD1232, KX-TA1232 and KX-TD308 Programming for Inband Integration via the Manager's Extension

Select a maximum of 2 station ports to be connected to the VPS. Plug each station into a Voice Mail port.

Go into System Program [602] and assign the Voice Mail stations to a different extension group. By default, all stations are in Extension Group 1.

Go into System Program [106] and assign the new Extension Group to Auto Attendant (AA).

3.3.5 KX-TD816, KX-TD1232, and KX-TA1232 Programming for Inband Integration via the Operating and Maintenance Tool

1. Go to the *Main Menu*. Choose "**System Data Programming**". (BATCH [1] or INTERACTIVE [2]).
 - Before choosing *Batch Programming*, you must open a file in the *Disk File Management Menu* (Item 3).
 - Before choosing *Interactive Programming*, you must connect with the system in the *DSHS Connect/Disconnect menu*.

Main Menu

1. System Data Programming (BATCH)
 2. System Data Programming (INTERACTIVE)
 3. Disk File Management
 4. DSHS Management
 5. DSHS Connect/Disconnect
 6. Quit
- Select the number : []

2. Choose "**Station**" from the *System Data Programming Main Menu*.

System Data Programming Main Menu

1. Line
 - 2. Station**
 3. System
 4. Toll Restriction
 5. ARS
 6. Aux. Ports
 7. Additional Function
 8. Caller ID
- Select the number: [2]

3. Choose "**Station Setting**" from the *Station Menu*.

Station Menu

- 1. Station Setting**
 2. COS & Mailbox ID
 3. CO line Outgoing
 4. DIL 1:N
 5. ISDN Extension Setting
 6. SDN Extension CO outgoing
 7. Flexible CO Keys
 8. Flexible PF Keys
 9. DSS
 10. Lunch/Break Group
 11. FWD/DND Setting
 12. FWD/DND Setting (OPX)
- Select the number: [1]

4. Enable XDP ports. Place Voice Mail extensions in Extension Group 8.

Station Setting

Jack	EXT	Name	X D P	E X G	Doorphone								LCS Mode	FWD N/A Time	Cordless PITS
					Day				Night						
01-1	[101]	[]	N	[1]	Y	Y	Y	Y	Y	Y	Y	Y	Stop Rec	[00]	N
01-2	[201]	[]	-	[1]	N	N	N	N	N	N	N	N		[00]	-
02-1	[102]	[]	N	[1]	N	N	N	N	N	N	N	N	Stop Rec	[00]	N
02-2	[202]	[]	-	[1]	N	N	N	N	N	N	N	N		[00]	-
03-1	[103]	[]	N	[1]	N	N	N	N	N	N	N	N	Stop Rec	[00]	N
03-2	[203]	[]	-	[1]	N	N	N	N	N	N	N	N		[00]	-
04-1	[104]	[]	N	[1]	N	N	N	N	N	N	N	N	Stop Rec	[00]	N
04-2	[204]	[]	-	[1]	N	N	N	N	N	N	N	N		[00]	-
05-1	[105]	[]	<u>Y</u>	[1]	N	N	N	N	N	N	N	N	Stop Rec	[00]	N
05-2	[205]	[]	-	[8]	N	N	N	N	N	N	N	N		[00]	-
06-1	[106]	[]	<u>Y</u>	[1]	N	N	N	N	N	N	N	N	Stop Rec	[00]	N
06-2	[206]	[]	-	[8]	N	N	N	N	N	N	N	N		[00]	-
07-1	[107]	[]	N	[1]	N	N	N	N	N	N	N	N	Stop Rec	[00]	N
07-2	[207]	[]	-	[1]	N	N	N	N	N	N	N	N		[00]	-
08-1	[108]	[]	N	[1]	N	N	N	N	N	N	N	N	Stop Rec	[00]	N
08-2	[208]	[]	-	[1]	N	N	N	N	N	N	N	N		[00]	-

5. Return to the System Data Programming Main Menu. Select "System".

6. Choose "Miscellaneous" from the System Menu.

System Menu

- | | |
|----------------------------|-----------------------------|
| 01. Day/Night | 14. Opera/Manager/EXT Group |
| 02. Class of Service | 15. Miscellaneous |
| 03. Emergency/Quick Dial | 16. Caller ID Modification |
| 04. Speed Dial | 17. Switch Type |
| 05. Absent Message | 18. DID |
| 06. Flexible Numbering | 19. Lunch/Break Time |
| 07. Account Code | 20. System Time |
| 08. Special Carrier | 21. Version |
| 09. Timer | 22. ISDN Card |
| 10. Voice Mail | 23. T1 Card |
| 11. Voice Mail Integration | 24. T1 Minor Error |
| 12. UCD | |
| 13. Phantom | |

Select the number: **[15]**

7. Choose the "Call Hunting" extension group. Set the last extension group to [A] for Automated Attendant.

Miscellaneous

Expansion Card Type (Master)	=> EXP1 COT	EXP2 EXT1	EXP3 EXT2				
(Slave)	=> COT	EXT1	EXT2				
Local Access => Priority = 1	2	3	4	5	6	7	8
TRG No. = [1]	[2]	[3]	[4]	[5]	[6]	[7]	[8]
Call Hunting => EXG No. = 1	2	3	4	5	6	7	8
	D	D	D	D	D	D	A
SPD TRS Override	=> Disable	HOTEL FEATURE		=> Off			
CO Auto-Hold by Push DSS-Key	=> Enable	DID SELECT		=> EXT Number			
CO-Key	=> Disable	Off-Hook Monitor		=> Enable			
Adjust Time	=> [01:00] AM						
PBX Code	=> []	Caller ID Extension					
		EXP 1	Not Stored				
		EXP 2	Not Stored				
		EXP 3	Not Stored				
		EXP 4	Not Stored				

8. Return to the System Data Programming Main Menu. Select "Line" and then select "CO Line Setting 1". Program all lines DIL to the first extension of the Voice Mail hunt group.

CO Line Setting

CO No	C	T	D	D	P	C	CPC		DIL 1:1		R	DIL 1:1	
	O	R	I	T	P	I	Detection	Out	EXT No	EXT No	E	Lunch Group	Break Group
	N	G	A	M	S	D	Mode		Day	Night	V		
			L	F									
01	Y	[1]	D	80	10	N	Disable	Disable	<u>EXT[205]</u>	<u>EXT[205]</u>	Reg.	[]	[]
02	Y	[2]	D	80	10	N	Disable	Disable	<u>EXT[205]</u>	<u>EXT[205]</u>	Reg.	[]	[]
03	Y	[3]	D	80	10	N	Disable	Disable	<u>EXT[205]</u>	<u>EXT[205]</u>	Reg.	[]	[]
04	Y	[4]	D	80	10	N	Disable	Disable	<u>EXT[205]</u>	<u>EXT[205]</u>	Reg.	[]	[]
05	Y	[5]	D	80	10	N	Disable	Disable	<u>EXT[205]</u>	<u>EXT[205]</u>	Reg.	[]	[]
06	Y	[6]	D	80	10	N	Disable	Disable	<u>EXT[205]</u>	<u>EXT[205]</u>	Reg.	[]	[]
07	Y	[7]	D	80	10	N	Disable	Disable	<u>EXT[205]</u>	<u>EXT[205]</u>	Reg.	[]	[]
08	Y	[8]	D	80	10	N	Disable	Disable	<u>EXT[205]</u>	<u>EXT[205]</u>	Reg.	[]	[]
09	Y	[8]	D	80	10	N	Disable	Disable	<u>EXT[205]</u>	<u>EXT[205]</u>	Reg.	[]	[]
10	Y	[8]	D	80	10	N	Disable	Disable	<u>EXT[205]</u>	<u>EXT[205]</u>	Reg.	[]	[]
11	Y	[8]	D	80	10	N	Disable	Disable	<u>EXT[205]</u>	<u>EXT[205]</u>	Reg.	[]	[]
12	Y	[8]	D	80	10	N	Disable	Disable	<u>EXT[205]</u>	<u>EXT[205]</u>	Reg.	[]	[]

3.3.6 KX-TD308 Programming for Inband Integration via the Operating and Maintenance Tool

1. Go to the *Main Menu*. Choose "**System Data Programming**".
(BATCH [1] or INTERACTIVE [2])

- Before choosing Batch Programming, you must open a file in the Disk File Management Menu (Item 3).
- Before choosing Interactive Programming, you must connect with the system in the DSHS Connect/Disconnect menu.

Main Menu

1. System Date Programming (BATCH)
 2. System Date Programming (INTERACTIVE)
 3. Disk File Management
 4. DSHS Management
 5. DSHS Connect/Disconnect
 6. Quit
- Select menu Number:[]

2. Choose "**Station (ALT-S)**" from the *System Data Programming Main Menu*.

System Data Programming Main Menu

- AuxPorts (ALT-U)
- Manager (ALT-M)
- System (ALT-Y)
- CO-Line (ALT-L)
- Station (ALT-S)**
- TRS (ALT-T)
- ARS (ALT-A)

3. Choose "**Settings (1)**" in the *Sub Menu*.

Sub Menu

- | | |
|--------------------------|----------|
| Settings (1) | 1 |
| Settings (2) | 2 |
| CO Line (O)utgoing | O |
| (D)il Line 1:N | D |
| Flex (C)o Keys :1-24 | C |
| Flex (P) F Buttons :1-12 | P |

4. Choose which single line extensions will be attached to Voice Mail.
If using XDP ports, **enable "XDP"** for the connect jacks.
Place Voice Mail extensions in Extension Group "**8**".

Station Setting 1

Jack	Ext.	Name	XDP	EXG	DoorPhone		LCS Mode	
					Day	Night		
1-1	[11]]	[[N]	[1]	[Y]	[Y]	[STOP REC]
1-2	[21]]	[[1]	[N]	[N]	
2-1	[12]]	[[N]	[1]	[N]	[N]	[STOP REC]
2-2	[22]]	[[1]	[N]	[N]	
3-1	[13]]	[[N]	[1]	[N]	[N]	[STOP REC]
3-2	[23]]	[[1]	[N]	[N]	
4-1	[14]]	[[N]	[1]	[N]	[N]	[STOP REC]
4-2	[24]]	[[1]	[N]	[N]	
5-1	[15]]	[[Y]	[1]	[N]	[N]	[STOP REC]
5-2	[25]]	[[8]	[N]	[N]	
6-1	[16]]	[[N]	[1]	[N]	[N]	[STOP REC]
6-2	[26]]	[[1]	[N]	[N]	
7-1	[17]]	[[N]	[1]	[N]	[N]	[STOP REC]
7-2	[27]]	[[1]	[N]	[N]	
8-1	[18]]	[[N]	[1]	[N]	[N]	[STOP REC]
8-2	[28]]	[[1]	[N]	[N]	

5. Select "SAVE(F7)". Return to the *System Data Programming Main Menu*. Select "System".

6. Choose "System (ALT-Y)" from the *System Data Programming Main Menu*.

System Data Programming Main Menu

- Auxports (ALT-U)
- Manager (ALT-M)
- System (ALT-Y)**
- CO-Line (ALT-L)
- Station (ALT-S)
- TRS (ALT-T)
- ARS (ALT-A)

7. Choose "Miscellaneous" from the *System Menu*.

System Menu

(A)ccount Codes	A
Caller (I)D	I
Class of Se(R)vice	R
(D)ay/Night	D
(E)mergency/Quick Dial	E
(F)loating Extensions	F
Fle(X)ible Numbers	X
(M)iscellaneous	M
P(H)antom Extensions	H
Seria(L) Interface	L
S(P)ecial Carrier	P
(T)imers	T
Add. F(U)ctions - SYSTEM	U
Add. Functions - (C)OS	C
(V)M Status/Command DTMF Set	V
Voice Mail Inte(G)ration	G

8. Choose the "Call Hunting" extension group. **Set** the last extension group to "[AA]" for Automated Attendant.

Miscellaneous

Automatic Access => Priority	=> 1	2	3						
CO No.	=> [1]	[2]	[3]						
Call Hunting => EXG No.	=> 1	2	3	4	5	6	7	8	
	[DIS]	[DIS]	[DIS]	[DIS]	[DIS]	[DIS]	[DIS]	<u>[AA]</u>	
Automatic Hold By CO Button	=> [Disable]								
Automatic Hold By DSS Button	=> [Enable]								
SPD TRS Override	=> [Disable]								
FAX Transfer Extension	=> []								
Caller ID Extension	=> []								
Caller ID Modification									
Area Code	=> []								
Local Call Del,Add	=> [3] []								
Long Distance Call Del,Add	=> [0] [1]								

9. Select "SAVE(F7)". Return to the *System Data Programming Menu*.

10. Choose "CO-Line (ALT-L)" from the *System Data Programming Main Menu*.

System Data Programming Main Menu

- AuxPorts (ALT-U)
- Manager (ALT-M)
- System (ALT-Y)
- CO-Line (ALT-L)**
- Station (ALT-S)
- TRS(ALT-T)
- ARS(ALT-A)

11. Choose "Settings (2)" in the *Sub Menu*, and program all lines DIL to the first extension of the Voice Mail hunt group.

Sub Menu

- Settings (1) 1
- Settings (2) 2**
- (I)ntercept/Timers/PBX Access Code I

CO Line Setting

CO	CPC		DIL 1:1 EXT NO.	
	Signal Detection Incoming	Signal Detection Outgoing	DAY	NIGHT
1	[400 ms]	[Disable]	[25]	[25]
2	[400 ms]	[Disable]	[25]	[25]
3	[400 ms]	[Disable]	[25]	[25]

3.3.7 KX-TDA/KX-TAW series Programming for Inband Integration

Whenever possible, we recommend that you use DPT Integration. However, in some cases, this is not possible. In the following situations, you need to use Inband Integration:

- Your PBX is a third-party telephone system.
- You have a KX-TDA/KX-TAW series PBX, but all the extension cards are analogue types.

1. Assignment of VM (DTMF) Group

- Go to the "3.Groups-8.VM(DTMF) Group-2.Group Setting" screen.
- Assign a floating extension number to the desired VM (DTMF) group.
- Assign extension numbers to "Extension Number of the SLT Port connected to VM". Incoming calls will hunt starting at the lowest VM Port number.
- Click "Apply" to save the changed data.

Screen output:

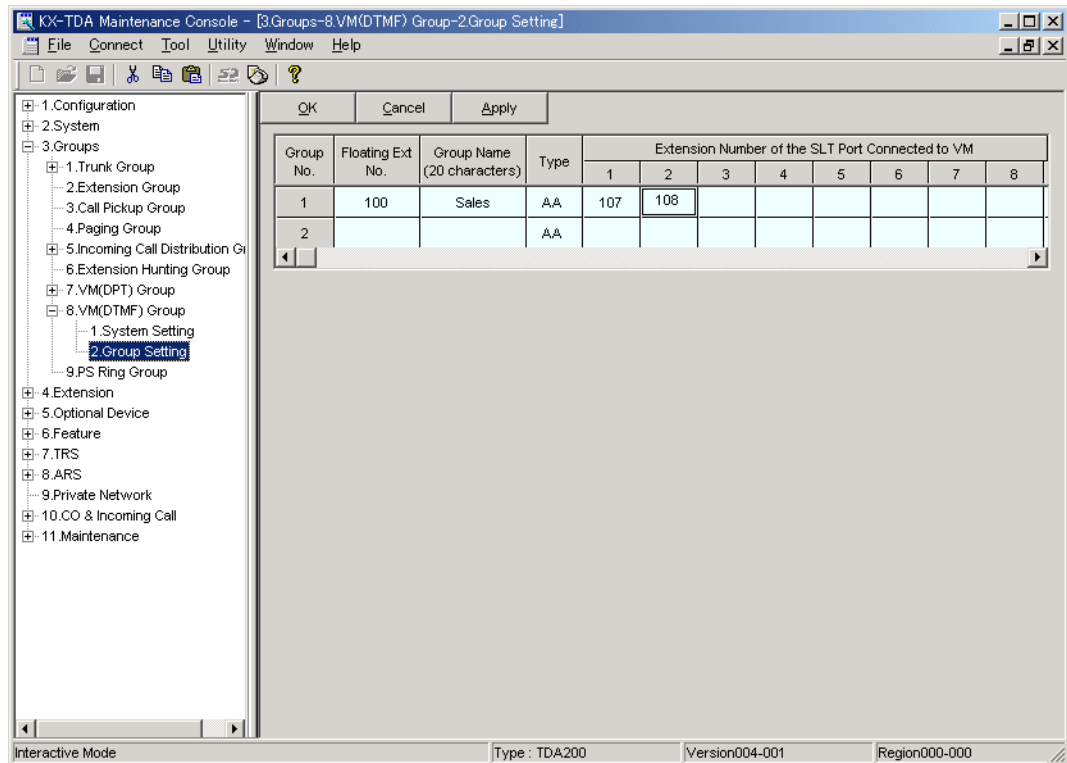

Note

The above screen output is an example of the KX-TDA200.

2. Settings for the trunk (outside line) features

Select the appropriate trunk (outside line) feature settings depending on how your customer plans to use the VPS.

- The VPS answers all incoming outside calls promptly.
Go to [Recommended Settings (1)].
- The VPS answers when the operator does not take the call after a specified time.
Go to [Recommended Settings (2)].
- The VPS answers when an Incoming Call Distribution Group does not take the call after a specified time.
Go to [Recommended Settings (3)].

[Recommended Settings (1)]

If the VPS is answering all incoming outside calls:

a) Assignment of DIL 1:1 line

- 1) Go to the "10.CO & Incoming Call-2.DIL Table & Port Setting" screen.
- 2) Assign "DIL Destination Day/Night/Lunch/Break" for each trunk (outside line) to a floating extension number (VPS Port).
- 3) Click "Apply" to save the changed data.

Screen output:

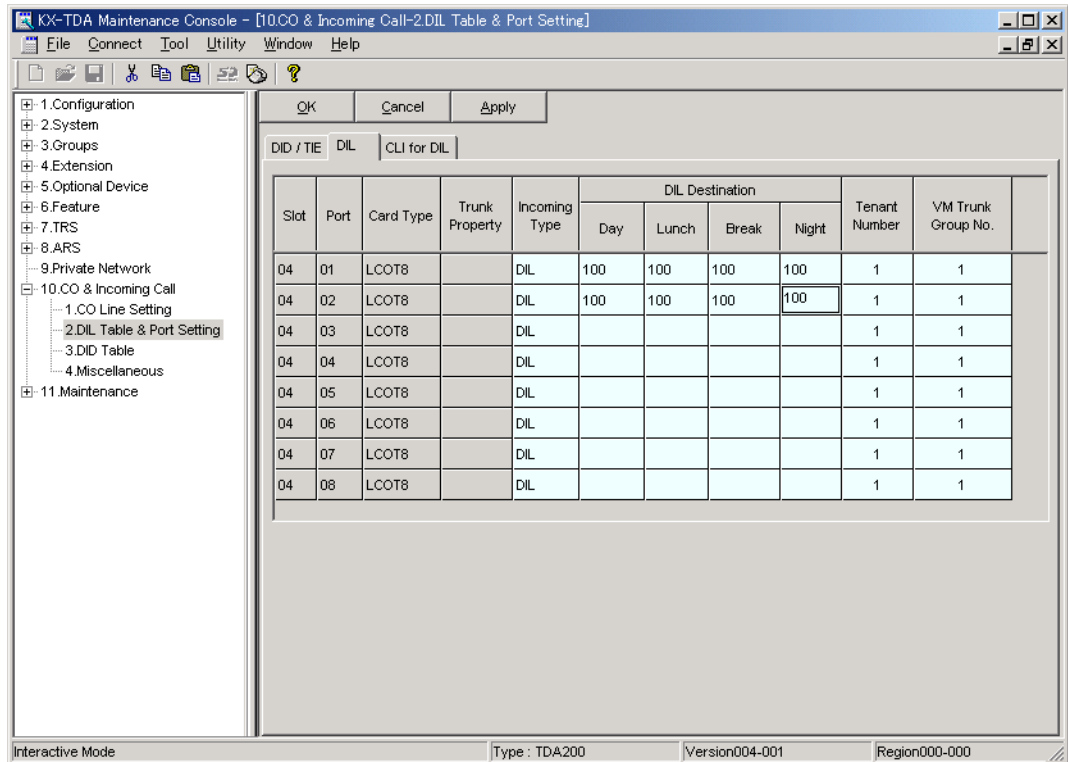

Notes

- The above screen output is an example of the KX-TDA200.
- The above screen output appears only when all the trunk cards mounted on your PBX are LCOT8 cards.

[Recommended Settings (2)]

If the VPS answers when the operator does not take the call after a specified time:

a) Assignment of DIL 1:1 line

If the VPS is answering all incoming outside calls:

- 1) Go to the "10.CO & Incoming Call-2.DIL Table & Port Setting" screen.**
- 2) Assign "DIL Destination Day/Night/Lunch/Break" for each trunk (outside line) to a specific extension number (operator extension).**
- 3) Click "Apply" to save the changed data.**

Screen output:

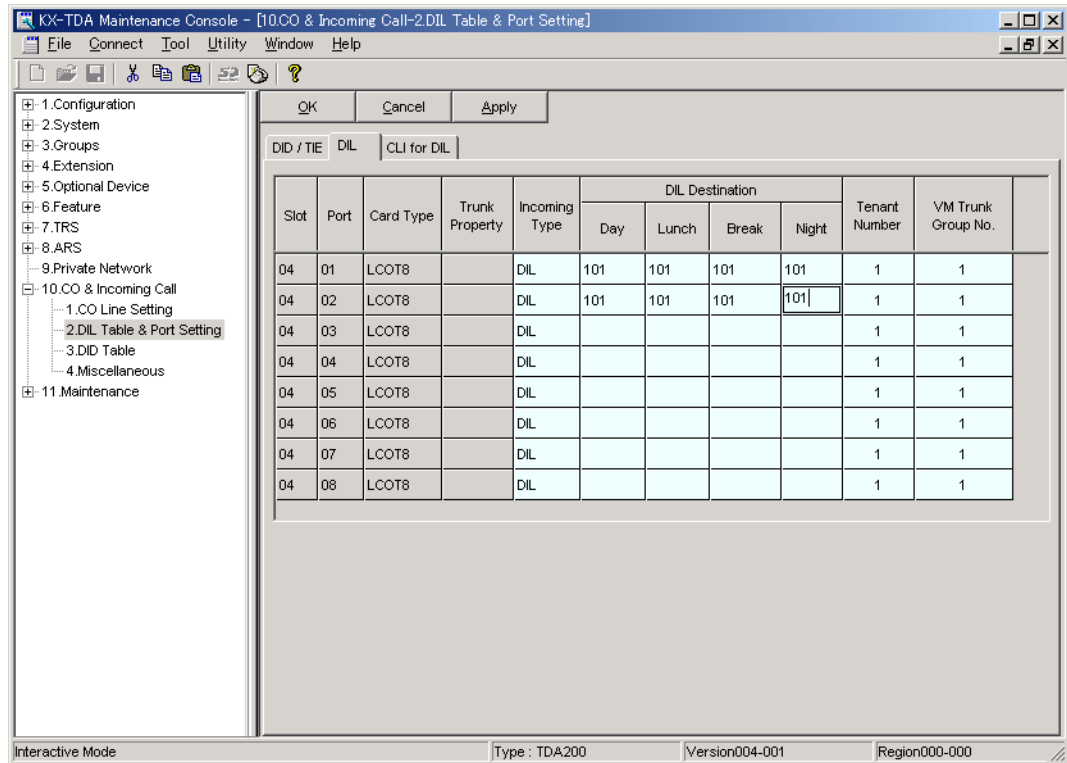

Note

The above screen output is an example of the KX-TDA200.

- b) Assignment of IRNA (Intercept Routing No Answer) destination:
 - 1) Go to the "4.Extension-1.Wired Extension-1.Extension Settings" screen.
 - 2) Assign "Intercept Destination Day/Night/Lunch/Break" for the operator's extension to a floating extension number (VPS Port).
 - 3) Click "Apply" to save the changed data.

Screen output:

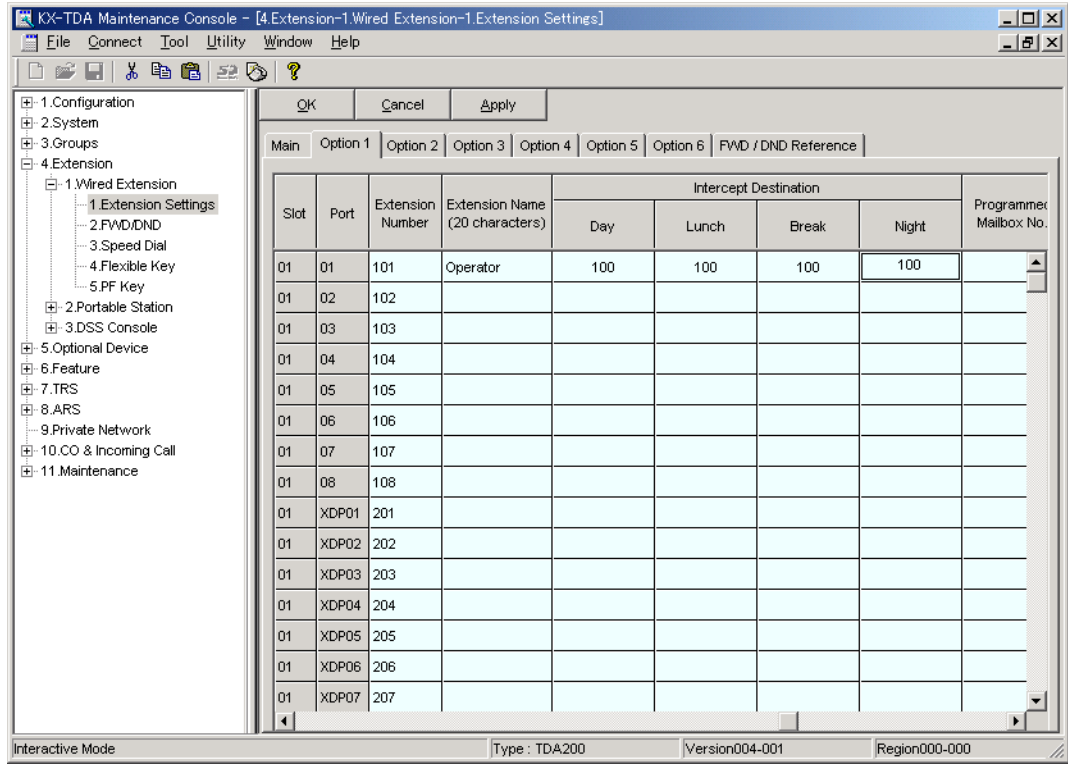

Note

The above screen output is an example of the KX-TDA200.

- c) Assignment of IRNA (Intercept Routing No Answer) timer:
- 1) Go to the "2.System-4.Timers & Counters-1.CO / Extension" screen.
 - 2) Assign "Intercept Timer" parameter.
 - 3) Click "Apply" to save the changed data.

Note

This parameter tells the KX-TDA/KX-TAW series how long to let a call ring at an extension before forwarding (redirecting).

Screen output:

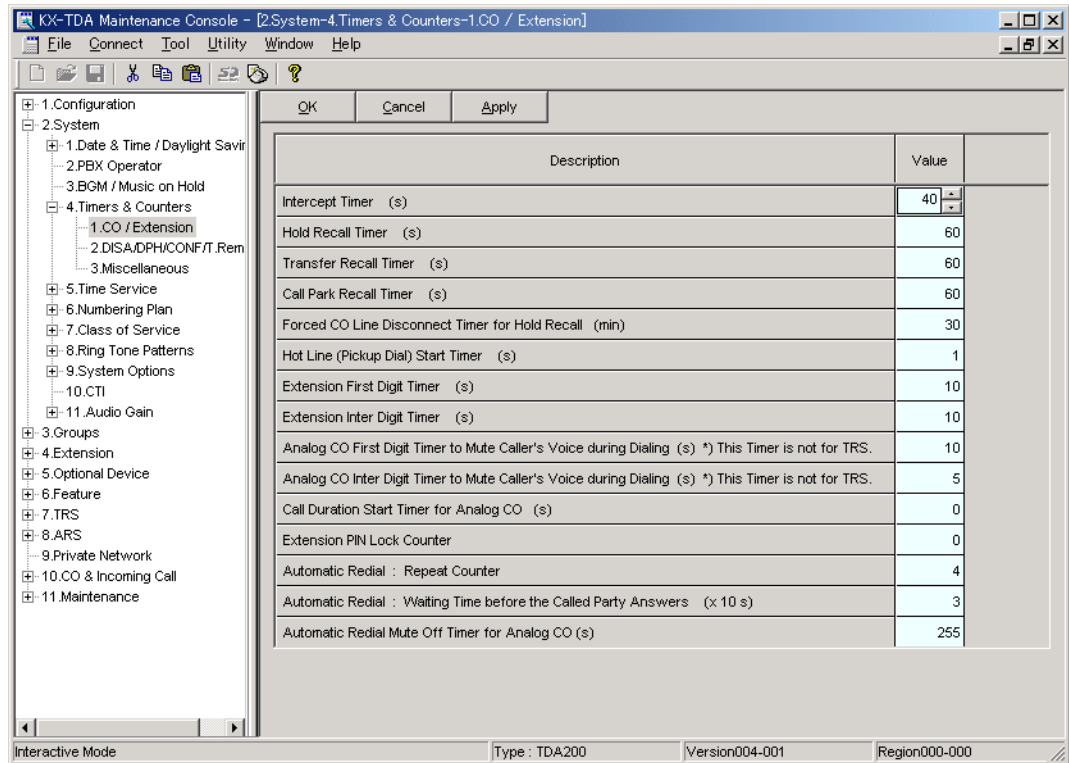

Note

The above screen output is an example of the KX-TDA200.

[Recommended Settings (3)]

If the VPS answers when an Incoming Call Distribution Group does not take the call after a specified time:

- a) Assignment of DIL 1:1 line
 - 1) Go to the "10.CO & Incoming Call-2.DIL Table & Port Setting" screen.
 - 2) Assign "DIL Destination Day/Night/Lunch/Break" for each trunk (outside line) to a specific extension number (floating extension number of the Incoming Call Distribution Group).
 - 3) Click "Apply" to save the changed data.

Screen output:

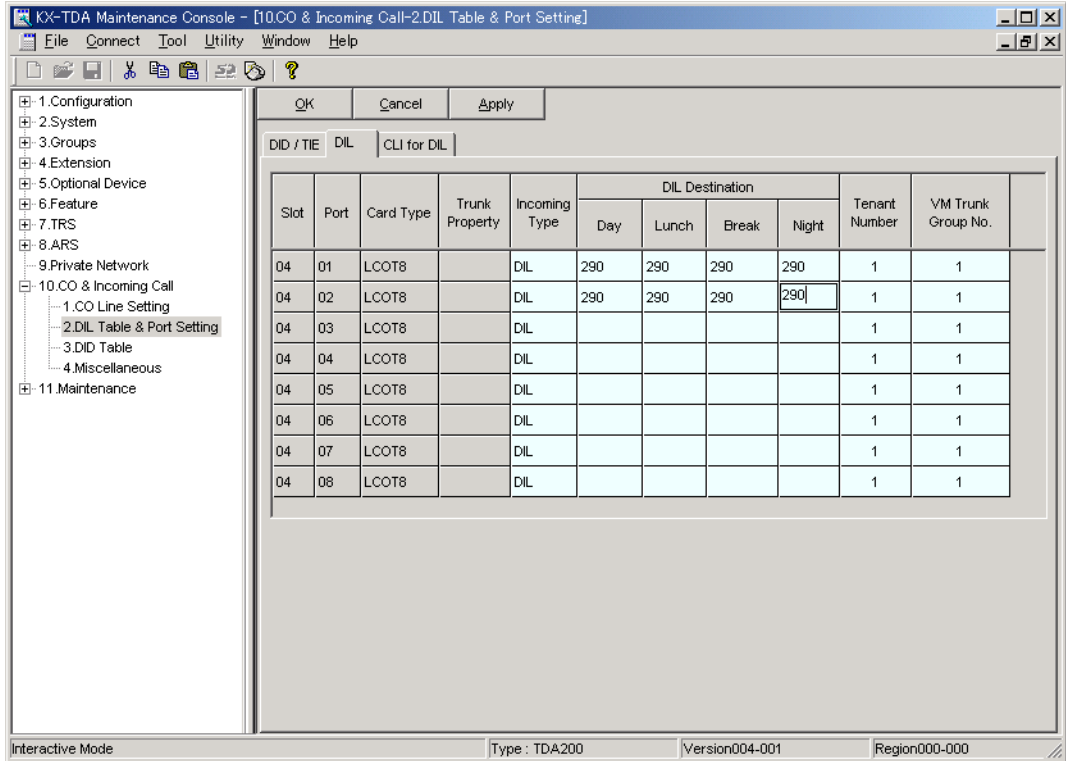

Notes

- The above screen output is an example of the KX-TDA200.
- For more information on programming the Incoming Call Distribution Group (e.g., VM Group Assignment, Incoming Call Distribution Group Member Assignment), refer to the KX-TDA/KX-TAW series manuals. For example, if the "DIL Destination" for the Incoming Call Distribution Group is assigned to floating extension number 290, the above screen will be displayed.

- b) Assignment of overflow destination:
 - 1) Go to the "3.Group-5.Incoming Call Distribution Group-1.Group Setting" screen.
 - 2) Assign "Time out & Manual Queue Redirection-Destination" for the Incoming Call Distribution Group to a floating extension number (VPS Port).
 - 3) Assign "Overflow Time" parameter.
 - 4) Click "Apply" to save the changed data.

Screen output:

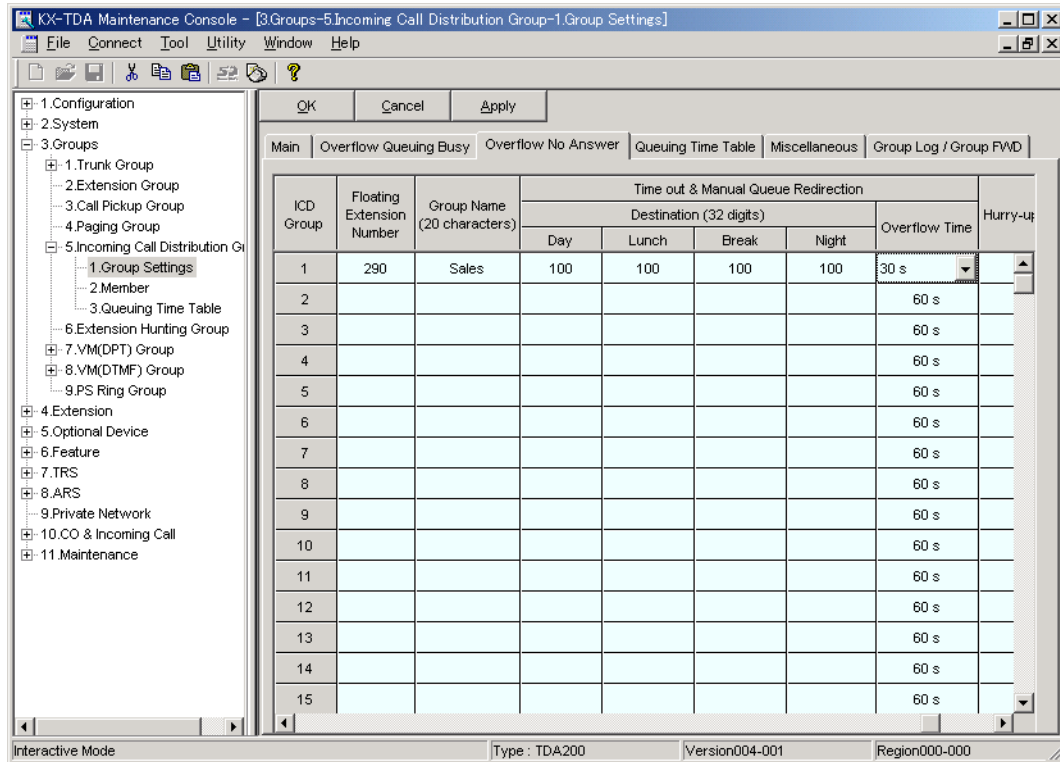

Note

The above screen output is an example of the KX-TDA200.

3. Setting for Intercept Routing to a Mailbox of the VPS.

Callers' messages can be recorded as soon as calls (intercom calls and incoming calls for an Incoming Call Distribution Group) are intercepted by the VPS, by following the steps below:

- a) Go to the "3.Groups-8.VM(DTMF) Group-1.System Setting" screen.
- b) Assign "Intercept Routing to the VPS Sequence" to "Answer by Mailbox".
- c) Click "Apply" to save the changed data.

Screen output:

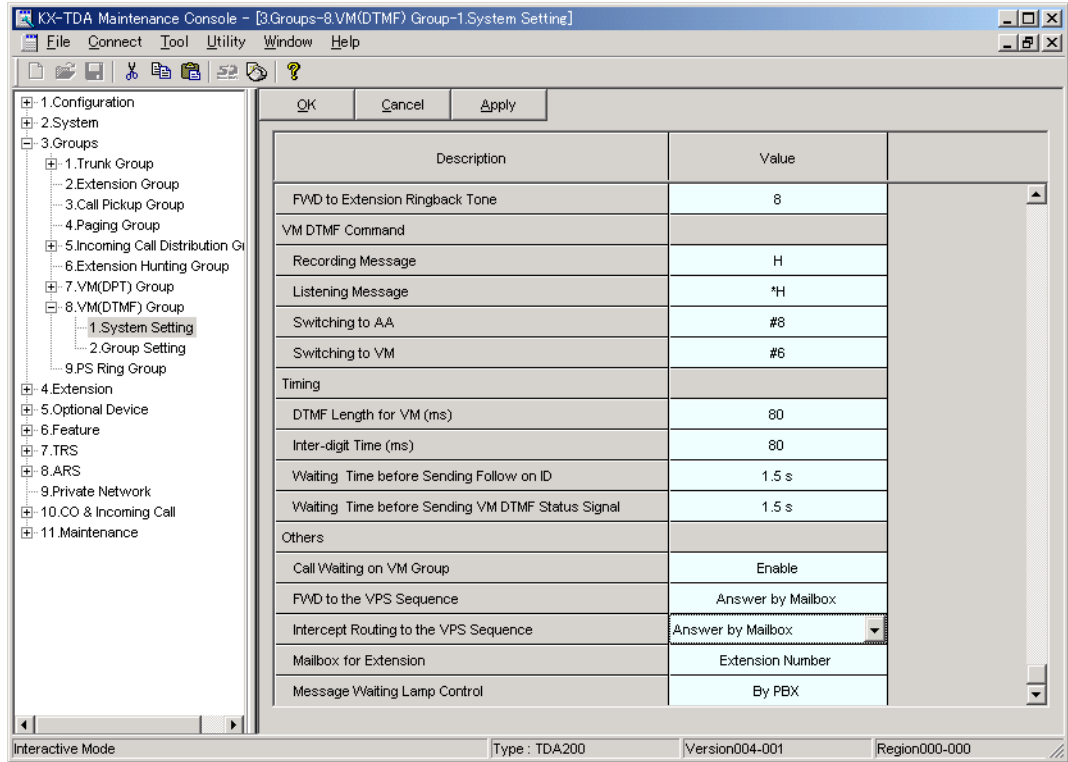

Note

The above screen output is an example of the KX-TDA200.

Section 4

***INTEGRATING THE VPS WITH THE
PANASONIC KX-T DIGITAL PBX***

4.1 GUIDELINES FOR DPT INTEGRATION

4.1.1 Why DPT Integration is Important

The VPS works well with most PBXs because its connections are made through a standard single line (tip/ring) telephone interface. However, the communication between the PBX and VPS is best when DPT Integration is used; the VPS is already set up to communicate through DPT Integration.

Once DPT Integration is established, the PBX sends information to the VPS through the data link. This information enables the VPS to identify the extension that is calling, know where from and why a call is forwarded, and recognize what the caller wants to do. This communication allows features that are only available with DPT Integration—several of which are described below:

Table 4-1 DPT INTEGRATION FEATURES

Remote Call Forwarding Set	The subscribers and the Message Manager can program their extensions from a remote location to forward various types of calls to a desired extension or an outside telephone.
Auto Configuration	The VPS knows what extension names/numbers exist on the PBX and creates mailboxes for each extension automatically. Also sets the VPS clock with data from the PBX clock.
Live Call Screening	Extension users can monitor messages as they are being left in the mailbox or intercept if required.
Two-Way Recording	Extension users can record conversations into their own mailboxes by pressing one button.
Two-Way Transfer	Extension users can record conversations into another person's mailbox by pressing a button and dialing an extension number.
One-Touch Two-Way Transfer	An extension user can record his conversation in another person's mailbox by just pressing one button. Available only with KX-TDA/KX-TAW series.
Direct Mailbox Access	The subscriber can directly enter his mailbox when he calls the VPS. He does not have to dial his mailbox number.
Trunk Service (Universal Port)	Each PBX trunk (CO line) group can be assigned one of 4 incoming call services: Voice Mail Service, Automated Attendant Service, Interview Service and Custom Service.
Intercom Paging*¹	Callers can page subscribers through built-in speakers and external paging equipment. For a Caller ID Caller, if his name has been recorded for the Caller Name Announcement feature, the name will be announced at the end of the page.

Table 4-1 DPT INTEGRATION FEATURES

Caller Name Announcement (System/Personal)*¹	The VPS announces the prerecorded Caller ID callers' names when: (1) extension users listen to messages from assigned numbers left in their mailboxes, (2) the VPS transfers calls from assigned numbers to the users, and (3) the VPS pages the users by intercom. If the same Caller ID number is programmed for both system and personal caller name announcements, the VPS will use the personal caller name.
Caller ID Call Routing*¹	The VPS automatically sends calls from pre-assigned Caller ID numbers to the specified extension, mailbox or Custom Service.
DID Call Routing*²	The VPS automatically sends calls from pre-assigned DID numbers to the specified extension, mailbox or Custom Service.
Personal Greeting for Caller ID*¹	Each subscriber can record up to 4 personal greeting messages for special callers.
Time Synchronization	Whenever the PBX sets a new date and time or when DPT Integration is established, the data is automatically registered in the VPS.
Toll Saver*²	Subscribers can check their mailboxes from pre-assigned Caller ID numbers or by dialing a pre-assigned DID number without telephone charges.

*¹ When an incoming outside call reaches the VPS via the PBX, the VPS will wait about 2 rings before answering the call to receive the Caller ID information properly from the PBX.

This waiting time can be changed by using the WCID command (see 7.2.20 Wait for Caller ID (WCID) in 7.2 UTILITY COMMANDS).

*² DID Call Routing and Toll Saver using DID numbers are only available when the VPS is connected to the following PBXs with DPT Integration.

- KX-TD816 (P311Q or higher)
- KX-TD1232 (P211Q or higher)
- KX-TD500 (V4M or higher)

Note

Depending on the model and/or the software version of the connected PBX (see 3.1.1 DPT or Inband Signaling?), you may not be able to utilize some of the features listed above. For more information, call National Parts Center at 1-800-833-9626.

4.2 KX-TD500 PROGRAMMING FOR DIGITAL INTEGRATION

A maximum of 2 VPS cards for the VPS can be installed at the KX-TD500. Follow the procedure below to program the VPS card(s) for DPT Integration.

Note

The following procedure is for when connecting the KX-TVS325; please refer to it when connecting the KX-TVS125 or KX-TVS225.

1. Assignment of the VPS card to be connected to the VPS

Note

If the VPS card to which the VPS will be assigned is already installed in the KX-TD500, skip the steps a through d. If a new VPS card is installed in the KX-TD500, follow the steps below.

- a) Go to the "1-1 Slot Assignment" screen.
- b) Assign the slot "Card Type" to be installed to "DLC" or "DHLC" card.
- c) Click "Apply" to save the card type assignment.
- d) Set "Status" to "INS".

Screen output:

Basic Shelf			Expansion Shelf 1			Expansion Shelf 2		
Slot No.	Card Type	Status	Card Type	Status	Card Type	Status	Card Type	Status
1	DHLC	INS						
2								
3								
4	DHLC	INS						
5								
6	ELCOT	INS						
7	DLC	INS						
8								
9								
10								
11								
12								
13	CPU							
14	TSW							

- e) Check the information of "Card Properties" and confirm the **LPR version** of the card.

Note

The LPR Version must be "2" or higher for the first VPS card (101: DLC/DHLC) to which the control channel will be assigned, or "1" or higher for the second VPS card (201: DLC/DHLC).

Screen output:

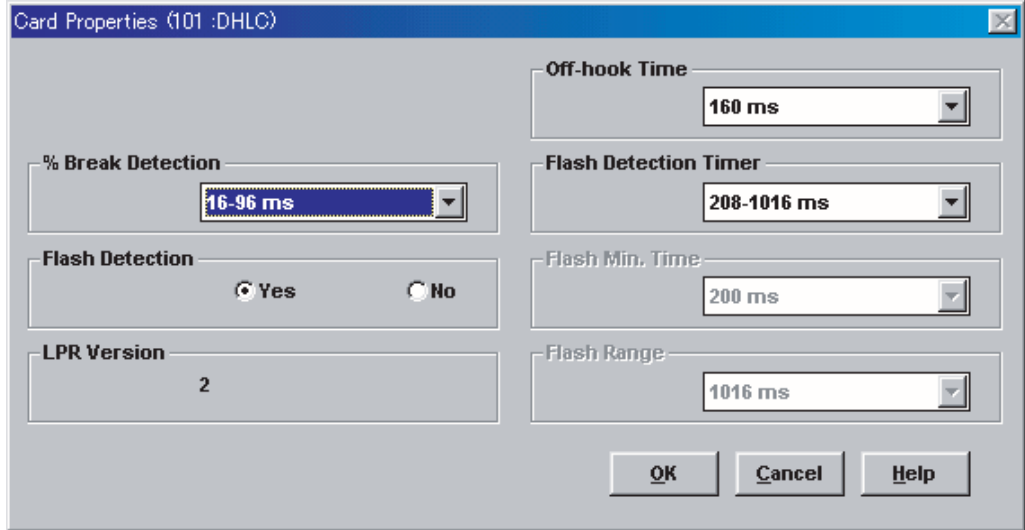

- f) Check the information of "CPU Card Information" and confirm the **Software Version** of the KX-TD500. The software version must be Q171A or higher for DPT Integration to be utilized.

Notes

- If the software version of the KX-TD500 is lower than this, you may not be able to utilize some of the features available only with DPT Integration. For more information, call National Parts Center at 1-800-833-9626.
- In the example below, Q171AB represents the software version and 010427A represents the software production date code (year, month, day).

Screen output:

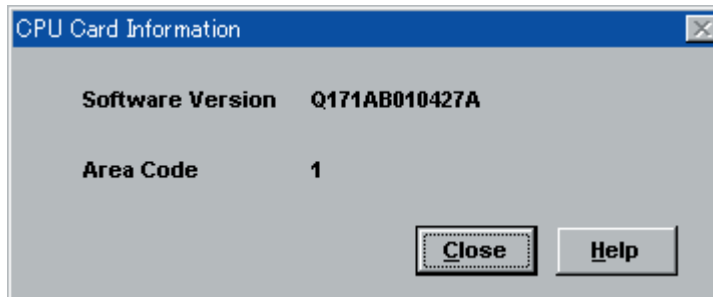

2. Assignment of the ports to be connected to the VPS
 - a) Go to the "1-3 Extension Port Assignment" screen.
 - b) Select the appropriate VPS card (101: DLC/DHLC or 201: DLC/DHLC) in the "Card No." menu.
 - c) Set the attribute of the valid ports to be connected to the VPS to "VPS (DPT)".
 - d) Click "Apply" to save the changed data.

Note

The parameters except for "Attribute" will disappear and the DN (Directory Number) will be cleared.

Screen output:

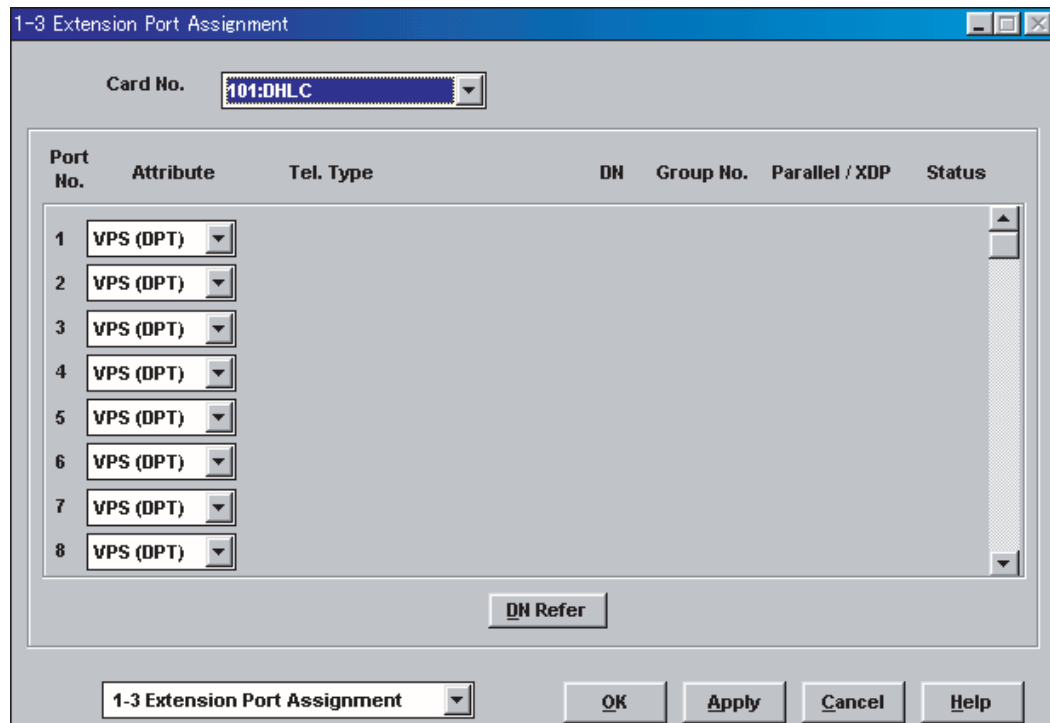

3. Assignment of VPS card and its model

- a) Go to the "1-4 VPS (DPT) Port Assignment" screen.
- b) Select the corresponding equipment number in the "TVS No." menu.
- c) Select your VPS model in the "Type" menu.
 - When connecting the KX-TVS125 or KX-TVS225, select "TVS80/110/200-1/200-2".

Note

Depending on the version of the KX-TD500, the selection might be "TVS200-1". In this case, select "TVS200-1" to connect the KX-TVS125 or KX-TVS225.

- When connecting the KX-TVS325, select "TVS300".

- d) Select the card (101: DLC/DHLC for jacks 1-8; 201: DLC/DHLC for jacks 9-12) which connects with the VPS in the "VPS Card" menu.

Screen output:

Jack No.	Port No.	Ext No. 1		Ext No. 2		Status
		DN	Group No.	DN	Group No.	
1						
2						
3						
4						
5						
6						
7						
8						
9						
10						
11						
12						

4. Assignment of the extension ports connected to the VPS
 - a) Continue the programming in the "1-4 VPS (DPT) Port Assignment" screen.
 - b) **Select** the extension port number of the card (DLC/DHLC) to which the VPS (DPT) jack is to be connected in the "**Port No.**" menu.

Notes

- You can assign a maximum of 12 jacks (24 ports) with the KX-TD500.
 - This menu is displayed only when the attribute of the ports is assigned to "VPS (DPT)" in step 2.
 - This program tells the KX-TD500 which extension ports are connected to the VPS. This allows the KX-TD500 to send the proper Digital Integration information to these ports.
 - Jack No.1 must be assigned, because its port is used as the channel to control the VPS.
- c) **Assign "DN"** for the port (click "**DN Refer**" to check the available directory numbers).

Note

This program allows you to assign an extension number to each Voice Mail port. Since each port connected to the VPS provides two extensions, this enables you to assign extension numbers to each port. To reach the Voice Mail system, users dial these extension numbers.

- d) **Assign "Extension Group No."** for the port.

Note

Specify the extension group number (126 or 127 by default) to which VM or AA is assigned. Group numbers 1 to 128 are available to the VPS through additional programming.
(Selecting VM has the same effect as selecting AA, regardless of how the VPS is programmed.)

- e) **Click "Apply"** to save the changed data.
- f) **Set "Status"** to "**INS**".

Screen output:

1-4 VPS (DPT) Port Assignment

TVS No.  VPS Card (Jack 1 - 8) 101:DHLC Type TVS300
 VPS Card (Jack 9 - 12) 104:DHLC

Jack No.	Port No.	Ext No. 1		Ext No. 2		Status
		DN	Group No.	DN	Group No.	
1	1	1065	126	1066	126	INS
2	2	1067	126	1068	126	INS
3	3	1069	126	1070	126	INS
4	4	1071	126	1072	126	INS
5	5	1073	126	1074	126	INS
6	6	1075	126	1076	126	INS
7	7	1077	126	1078	126	INS
8	8	1079	126	1080	126	INS
9	1	2065	126	2066	126	INS
10	2	2067	126	2068	126	INS
11	3	2069	126	2070	126	INS
12	4	2071	126	2072	126	INS

1-4 VPS (DPT) Port Assignment

5. To set the trunk (CO line) features, follow the instructions in "Settings for the trunk (CO line) features" (3.3.3 KX-TD500 Programming for Inband Integration in 3.3 CONNECTING THE VPS WITH PANASONIC KX-T SERIES PBXs).
6. Set the PBX to send DID numbers to the VPS.
 - a) Go to the "2-7 System Option 6" screen.
 - b) Enable "67.Sending DID Number to VPS".

Note

This setting enables the PBX to send DID numbers to the VPS. If you want to use the features which utilize DID numbers (e.g., Toll Saver, DID Call Routing), you must enable this setting.

Screen output:

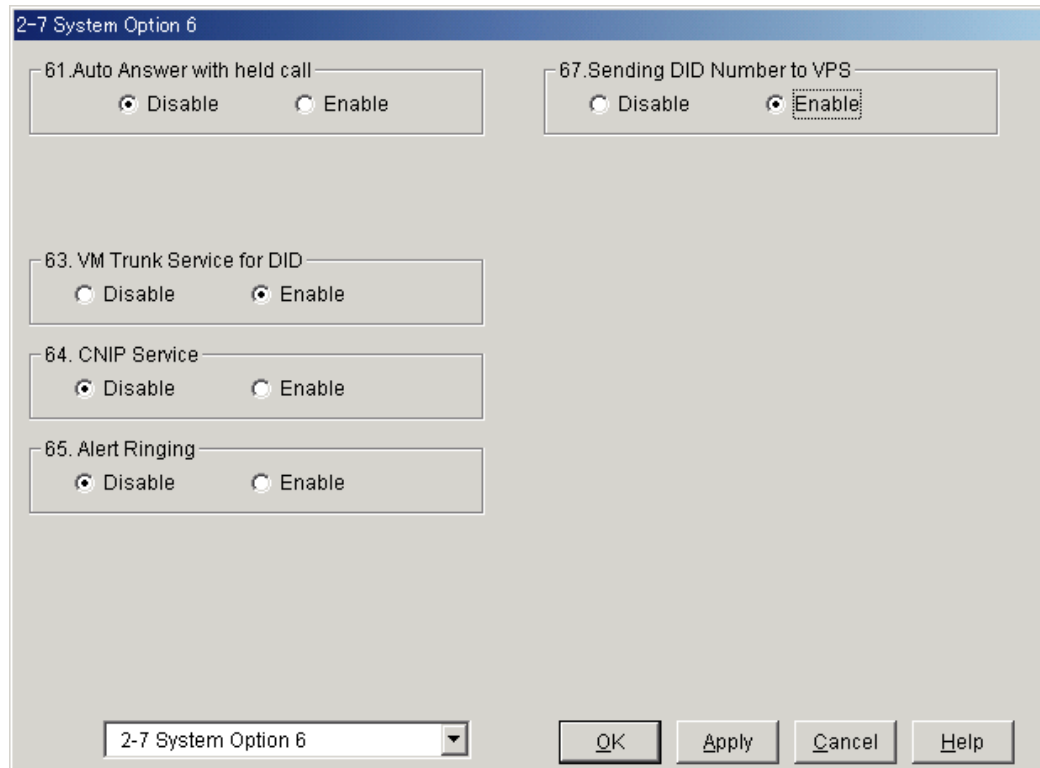

7. **Connect** the **jack** assigned in Step 4 to the VPS.
8. **Connect** your **personal computer** to the VPS and start your communication software (i.e., HyperTerminal, Procomm Plus, Smartcom...).
Communication Parameters: 9600, 8 Bit, None, 1
9. **Turn** the power switch **off** at the VPS and **set** the **DIP/Rotary Switch** to **position 5**.
Only perform this step when initially setting up the system.

CAUTION

Setting the DIP/Rotary Switch to position 5 will default the Voice Processing System, resulting in a loss of all user programming and voice messages (except User 1 and User 2 prompts).

10. **Turn** the power switch back **on** at the VPS and wait approximately 7-8 min while the system initializes.

Before starting the VPS, make sure all installation and line connections have been done as described in Section 2 INSTALLATION.

The calls to the VPS can be processed after the Power Indicator stops flashing. After turning the power on, the system starts up in the following sequence:

- *The Power Indicator light goes on.*
- *The Power Indicator light begins to flash.*
- *"CARD TEST" is displayed on the screen.*

- "SYSTEM SETUP" is displayed.

Screen output:

```

CARD TEST...
SYSTEM SETUP...
  1...  2...  3...  4...  5...  6...  7...  8...  9... 10...
11... 12... 13... 14... 15... 16... 17...
    
```

- The VPS tests the CPU board, the hard disk drive, and the CO cards as "SYSTEM SETUP..." is displayed.
- Active ports are displayed on the screen (the number of active ports depends on the VPS model).

Screen output:

```

Active COs: 1  2  3  4  5  6  7  8  9 10 11 12
          13 14 15 16 17 18 19 20 21 22 23 24
DPT Interface Connection is Established
Modem Card Initialization Completed
** ON LINE MODE **
    
```

Note

You will see "Modem Card Initialization Completed" only when connecting the KX-TVS325.

The display will alert you if System Setup is not completed successfully.

Screen output:

```

Active COs: 1  2  3  4  5  6  7  8  9 10 11 12
          13 14 15 16 17 18 19 20 21 22 23 24
DPT Interface Connection is not Established
Modem Card Initialization Completed
** OFF LINE MODE **
    
```

This message will appear when the DPT connection between the VPS and telephone system cannot be established.

Possible causes of the message: "DPT Interface Connection is not Established"

Table 4-2

Cause	Remedy
The PBX is not a KX-TD/KX-TDA/KX-TAW series or KX-TA1232 system. Since the VPS is configured to communicate with the default PBX type at the factory (KX-TD500 for the KX-TVS325; KX-TD1232 for the KX-TVS125 and KX-TVS225), this message will always appear when connecting to another type of PBX.	Connect a KX-TD/KX-TDA/KX-TAW series or KX-TA1232 PBX and set the PBX type by using Quick Setup (see Section 5 CUSTOMIZING THE SYSTEM).
The cabling between the PBX extension ports and the VPS is not 4-wire or is improperly connected.	Confirm the cabling is connected as described in Section 2 INSTALLATION.

Table 4-2

Cause	Remedy
The PBX is a KX-TD/KX-TDA/KX-TAW series or KX-TA1232 but does not have the proper level of software required to support DPT Integration.	Contact National Parts Center at 1-800-833-9626 or use Inband Integration under hardware settings.
The PBX is not programmed properly to support DPT Integration.	Do required integration programming as described in this chapter.

11. Start up completed.

- a) The Power Indicator light stops blinking when the start-up has been successful. (The delay varies according to the system's condition.)
- b) *****ON LINE MODE***** is displayed.
- c) System prompt [**>**] is displayed on the screen. To enter system administration, **Press ENTER**. All parameters can be set through the menu-driven program.

When the System Administrator starts operation, the system asks for the terminal type. By choosing VT100 [2], all parameters can be set through the menu-driven program.

Please Select Your Terminal Type.
1. ASCII TERMINAL
2. VT100
Please Enter the Number := _____

Please Enter the Number:= [2]

Select [2] because Quick Setup is only available when using a personal computer that can emulate a VT100 terminal.

- 12.** Go to the *System Administration Top Menu*. Select [5] and **Press ENTER**, or **Type [3]** then **QSET** and **Press ENTER** for Quick Setup and follow the Auto Configuration Instructions.

TEST: Press the INTERCOM button and then [1065]. If the VPS answers, you have a DPT connection.

Set the DIP/Rotary Switch to position 0 after initialization is complete.

The required programming is complete and the VPS and KX-TD500 should be able to communicate through DPT Integration.

We recommend that the KX-TD500 system has any optional extension cards installed and telephones connected before starting the VPS.

When running the Quick Setup command (Section 5 CUSTOMIZING THE SYSTEM) from the VPS, the PBX transmits the station information automatically. This saves time when programming the VPS.

4.3 KX-TDA/KX-TAW SERIES PROGRAMMING FOR DIGITAL INTEGRATION

A group of DPT ports connected to a VPS with DPT Integration is called "VM (DPT) Group" for the KX-TDA/KX-TAW series. Each VM (DPT) Group consists of a maximum of 12 ports (24 channels) of the VPS.

Only one VM (DPT) Group can be assigned for the KX-TDA50 and KX-TAW. On the other hand, up to two VM (DPT) Groups can be assigned for the KX-TDA100/TDA200; that is, two VPSs can be connected to one PBX.

It is necessary to assign the VM (DPT) Group and VM (DPT) extension ports to use DPT Integration.

1. Assignment of VM (DPT) Group
 - a) Go to the "3.Groups-7.VM(DPT) Group-2.Unit Setting" screen.
 - b) Assign a floating Extension Number for VM Unit number.
 - c) Click "Apply" to save the changed data.

Note

You can use a maximum two VM (DPT) groups (Unit No.1 and Unit No.2). All extension ports for one VM (DPT) group should be connected to only one DHLC card or only one DLC card.

Screen output:

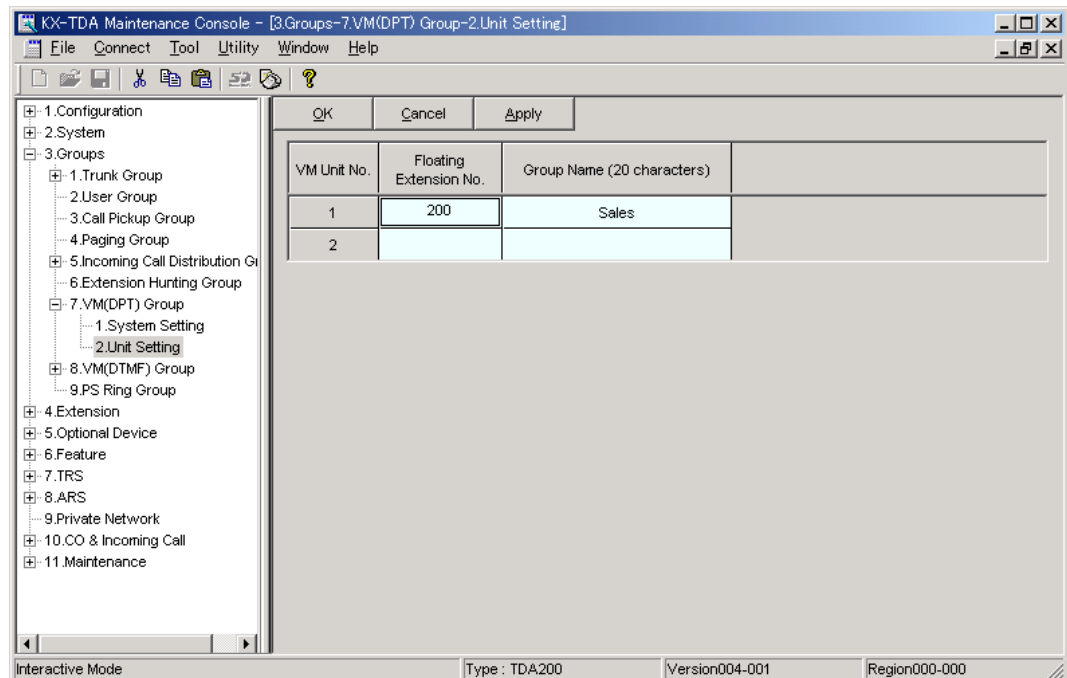

Note

The above screen output is an example of the KX-TDA200.

2. Assignment of VM (DPT) extension ports
 - a) Go to the "1.Configuration-8.Extension Port" screen. Follow the procedure below for the extension port which you want to assign as a VM port.
 - b) Select the attribute of "DPT Property-Type" to "VM (DPT)".
 - c) Assign "DPT Property-VM Unit No." and "DPT Property-VM Port No.". Incoming calls will hunt starting at the lowest VM Port number.
 - d) Click "Apply" to save the changed data.

Screen output:

Slot	Port	Telephone Type	Connection	Extension Number	Extension Name	XDP Mode	Parallel Telephone Ringing	DPT Property			
								Type	Location No.	VM Unit No.	VM Port No.
02	01	DPT	INS	109		Off	Yes	Normal	1	1	1
02	02	SLT	INS	110		Off	No	Normal	1	1	1
02	03	VM	INS	111	Voice Mail	On	No	VM (DPT)	1	1	1
02	04	DPT	INS	112		On	No	Normal	1	1	1
02	05	Connecti	OUS	113		On	No	Normal	1	1	1
02	06	DPT	INS	114		Off	Yes	Normal	1	1	1
02	07	DPT	INS	115		On	No	Normal	1	1	1
02	08	DPT	INS	116		On	No	Normal	1	1	1
02	XDP01	SLT	OUS	209							
02	XDP02	SLT	OUS	210							
02	XDP03	SLT	INS	211							
02	XDP04	SLT	INS	212							
02	XDP05	SLT	INS	213							
02	XDP06	SLT	OUS	214							

Note

The above screen output is an example of the KX-TDA200.

3. To set for the trunk features, follow the instructions in "Step 2 Settings for the trunk (outside line) features" in 3.3.7 KX-TDA/KX-TAW series Programming for Inband Integration.
4. Setting for Intercept Routing to a Mailbox of the VPS.

Callers' messages can be recorded as soon as calls (intercom calls and incoming calls for an Incoming Call Distribution Group) are intercepted by the VPS, by following the steps below:

 - a) Go to the "3.Groups-7.VM(DPT) Group-1.System Setting" screen.
 - b) Assign "Intercept to VM Sequence" to "Answer by Mailbox".
 - c) Click "Apply" to save the changed data.

Screen output:

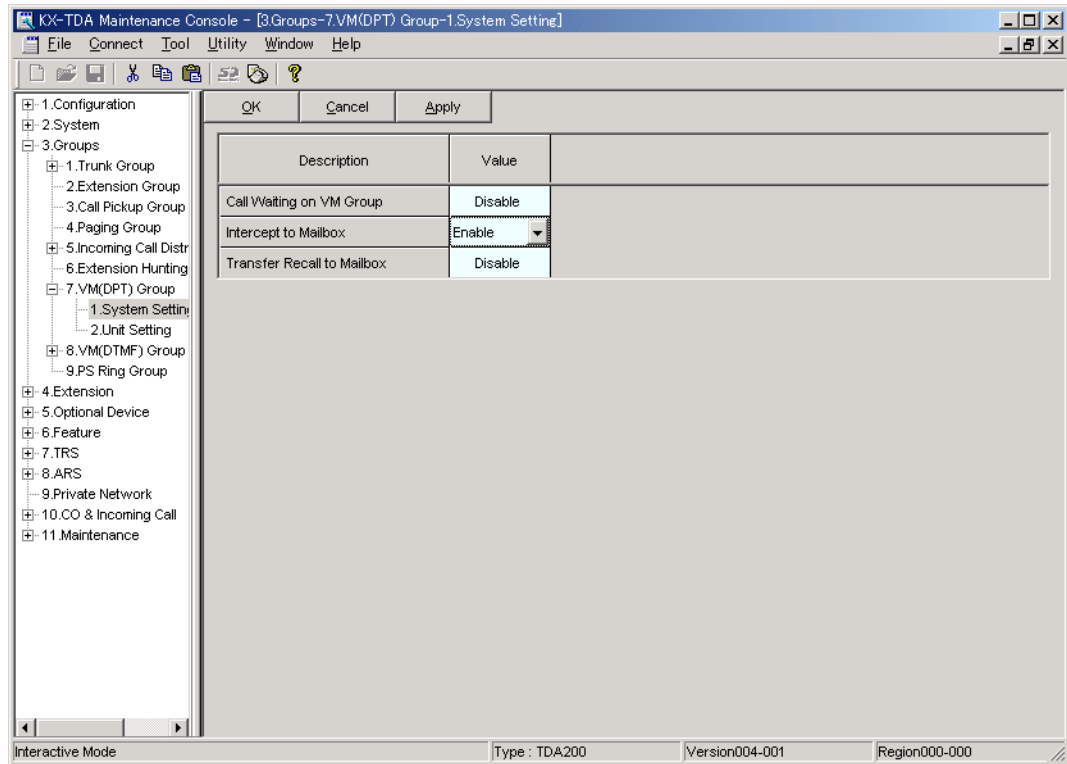

Note

The above screen output is an example of the KX-TDA200.

5. Connect the jack assigned in Step 3 to the VPS.
6. Connect your personal computer to the VPS and start your communication software (i.e., HyperTerminal, Procomm Plus, Smartcom...).
Communication Parameters: 9600, 8 Bit, None, 1
7. Disconnect the power from the VPS and set the DIP/Rotary switch on the VPS to position 5.

Only perform this step when initially setting up the system.

CAUTION

Setting the DIP/Rotary switch to position 5 will default the Voice Processing System, resulting in a loss of all user programming, and voice messages (except User 1 and User 2 prompts).

8. Plug in and power up the VPS and wait approximately 3.5 min while the system initializes.

"System Administration" Start-Up Sequence

Before starting the VPS, make sure all installation and line connections have been done as described in Section 2.

The calls to the VPS can be processed after the Power Indicator stops flashing. After turning the power on, the system starts up in the following sequence:

- *The Power Indicator light goes on.*
- *The Power Indicator light begins to flash.*
- *"CARD TEST" is displayed on the screen.*
- *"SYSTEM SETUP" is displayed.*

Screen output:

```

CARD TEST...
SYSTEM SETUP...
  1...  2...  3...  4...  5...  6...  7...  8...  9... 10...
11... 12... 13... 14... 15... 16... 17...
    
```

- *The VPS tests the CPU board, the hard disk drive, and the CO cards as "SYSTEM SETUP..." is displayed.*
- *Active ports are displayed on the screen (the number of active ports depends on the VPS model).*

Screen output:

```

Active COs: 1  2  3  4  5  6  7  8  9 10 11 12
             13 14 15 16 17 18 19 20 21 22 23 24
DPT Interface Connection is Established
Modem Card Initialization Completed
** ON LINE MODE **
    
```

Note

You will see "Modem Card Initialization Completed" only when connecting the KX-TVS325.

The display will alert you if System Setup is not completed successfully.

Screen output:

```

Active COs: 1  2  3  4  5  6  7  8  9 10 11 12
             13 14 15 16 17 18 19 20 21 22 23 24
DPT Interface Connection is not Established
Modem Card Initialization Completed
** OFF LINE MODE **
    
```

This message will appear when the DPT connection between the VPS and telephone system cannot be established.

Possible causes of the message: "DPT Interface Connection is not Established"

Table 4-3

Cause	Action
The cabling between the PBX extension ports and the VPS is not 4-wire or is improperly connected.	Confirm the cabling is connected as described in Section 2 INSTALLATION.

Table 4-3

Cause	Action
The PBX is not programmed properly to support DPT Integration.	Do required integration programming as described in this chapter.

9. Start up completed.
 - a) The Power Indicator light stops blinking when the start-up has been successful. (The delay varies according to the system's condition.)
 - b) "***ON LINE MODE**" is displayed.
 - c) System prompt [>] is displayed on the screen. To enter system administration, **Press ENTER**. All parameters can be set through the menu-driven program.

10. Go to the *System Administration Top Menu*. Type [5] and **Press ENTER**, or Type [3] then **QSET** and **Press ENTER** for Quick Setup and follow the Auto Configuration Instructions.

TEST: Press the INTERCOM button and then VM(DPT) floating group number which you assign in "1. Assignment of VM(DPT) Group". If the VPS answers, you have a DPT connection.

Set the DIP/Rotary switch to position 0 after initialization is complete.

The required programming is complete and the VPS and KX-TDA/KX-TAW should be able to communicate through Digital Integration.

When running the Quick Setup command (Section 5 CUSTOMIZING THE SYSTEM) from the VPS, the PBX transmits the station information automatically. This saves time when programming the VPS.

4.4 CONNECTING THE VPS WITH THE PANASONIC KX-TD816, KX-TD1232, KX-TA1232 AND KX-TD308

Notes

- Do not use system programs [106] or [602] for DPT Integration.
- The next 2 sections (4.4.1 KX-TD1232 Software Verification and Programming for DPT Integration via the Manager's Extension and 4.4.2 KX-TD1232 Software Verification and Programming for DPT Integration via the Operating and Maintenance Tool) are for the KX-TD1232 as examples. Please refer to them for the KX-TD816 or KX-TA1232.
- And the following Section (4.4.3 KX-TD308 Software Verification and Programming for DPT Integration via the Manager's Extension) is for the KX-TD308.

4.4.1 KX-TD1232 Software Verification and Programming for DPT Integration via the Manager's Extension

It is important that the KX-TD1232 has the proper software level to allow DPT Integration with the VPS. Follow the procedures below to confirm the software level, then complete the required programming before starting up the VPS.

Note

Two methods of programming are available on the KX-TD1232. The instructions below show how to program without the operating and maintenance tool. For instructions on programming with the operating and maintenance tool, please see 4.4.2 KX-TD1232 Software Verification and Programming for DPT Integration via the Operating and Maintenance Tool.

All of the following procedures must be done after entering system programming. Refer to the KX-TD1232 Programming Guide or Installation Manual for instructions on how to enter the system programming mode.

Software Verification

1. Verify Software—If you are configuring a 2-cabinet system, remember to check both cabinets. The software must be the same in each. Check the software version of the KX-TD1232 using System Program [116].

Example: **P231UYMMDDA**

The underlined digits represent the software production date code (year, month, day). For DPT Integration, the software version of the PBX must be P231U or higher. (For KX-TD816, the version must be P301O or higher; for KX-TA1232, the version must be P831AA or higher.)

If the software version of the PBX is lower than this, you may not be able to utilize some of the features available only with DPT Integration. For more information, call National Parts Center at 1-800-833-9626.

From the **SYS-PGM NO ?** screen:

- a) Enter [116].
- b) Press the **NEXT** button (SP-PHONE).
- c) Enter the system number ([0] or [1], master/slave). The system displays the ROM version and the date it was created.

This version must be P231U or higher for DPT Integration to be utilized (both systems if system connection is used).

2. Set the date and time using System Program [000].
3. Set PBX extension numbering using System Program [003].
4. Assign the **Voice Mail Port**. This program tells the PBX which jack will be connected to the VPS. This allows the PBX to send the proper DPT Integration information to those ports.

Notes

- You can assign a maximum of 6 jacks (12 ports) with the KX-TD1232. (6 jacks [12 ports] with the KX-TD816; 4 jacks [8 ports] with the KX-TA1232.)
- If you are configuring a 2-cabinet system, all Voice Mail Ports should be assigned to either the Master or Slave System.

From the **SYS-PGM NO ?** screen:

- a) Enter [117].
- b) Press the **NEXT** button (SP-PHONE).
Screen output: M: # # # #
- c) Enter the jack number (02-64) of the port you will use for the Voice Mail.
- d) Press **STORE**.
- e) Press **END** (HOLD) when finished.

Conditions: ***Jack 01 cannot be used as a Voice Mail port. A jack programmed as a Manager Extension (System Program [006]) cannot be used in this program.***

5. **Skip this step unless setting flexible numbering.**

System Program [118] (Voice Mail Extension Number Assignment) is automatically set. This program allows you to assign an extension number to each Voice Mail port. Since a jack connected to the VPS provides 2 extensions, this enables you to assign extension numbers to each port. You can assign any extension number that is not already assigned to another port. To reach the VPS, users dial these extension numbers. It is not necessary to change the default programming for the extensions 165 and 166.

From the **SYS-PGM NO ?** screen:

- a) Enter [118].
- b) Press the **NEXT** button (SP-PHONE).

Screen output: VM NO? →

- c) **Press** the **NEXT** button (SP-PHONE).
Screen output: VM-01:#_ _ -1: 165
(_ _ = the port number you entered in program 117)
- d) **Enter** the **Extension Number** that you want this port to have.
(The default extension number for port 1: 165; port 2: 166)
- e) **Press STORE.**
- f) Repeat steps c, d, and e until all extension numbers are entered.

Conditions: *No 2 jacks on the system can have the same extension number. If you try to enter a number that is already assigned, you will hear an error tone. Each digital extension connected provides 2 Voice Mail ports and must have 2 different extension numbers assigned.*

- 6. **Assign Bit 9 of COS 6** using System Program [991]. This program tells the PBX whether or not to send DID Information to the VPS.
 - a) **Enter [991].**
Screen output: COS Add Inf.
 - b) **Press NEXT.**
Screen output: COS NO? →
 - c) **Enter COS No. [6].**
Screen output: 111111111110000
 - d) **Move** the cursor to **Bit 9** (the 9th bit from the right), and **change [1] (default) to [0].**
Screen output: 111111011110000

Note

If Bit 9 is assigned to [1] (default), the PBX does not send DID information to VPS. If it is assigned to [0], the PBX sends DID information to VPS.

- 7. **Connect** the **jack** assigned in Step 4 to the VPS.
- 8. **Connect** your **personal computer** to the VPS and start your communication software (i.e., HyperTerminal, Procomm Plus, Smartcom...)
Communication Parameters: 9600, 8 Bit, None, 1
- 9. **Turn** the power switch **off** at the VPS and **set** the **DIP/Rotary Switch** to **position 5.**
Only perform this step when initially setting up the system.

CAUTION

Setting the DIP/Rotary Switch to position 5 will default the Voice Processing System, resulting in a loss of all user programming and voice messages (except User 1 and User 2 prompts).

- 10. **Turn** the power switch back **on** at the VPS and wait approximately 7-8 min while the system initializes.

Before starting the VPS, make sure all installation and line connections have been

done as described in Section 2 INSTALLATION.

The calls to the VPS can be processed after the Power Indicator stops flashing. After turning the power on, the system starts up in the following sequence:

- The Power Indicator light goes on.
- The Power Indicator light begins to flash.
- "CARD TEST" is displayed on the screen.
- "SYSTEM SETUP" is displayed.

Screen output:

```

CARD TEST...
SYSTEM SETUP...
  1...  2...  3...  4...  5...  6...  7...  8...  9... 10...
11... 12... 13... 14... 15... 16... 17...
    
```

- The VPS tests the CPU board, the hard disk drive, and the CO cards as "SYSTEM SETUP..." is displayed.
- Active ports are displayed on the screen (the number of active ports depends on the VPS model).

Screen output:

```

Active COs: 1  2  3  4  5  6  7  8  9 10 11 12
           13 14 15 16 17 18 19 20 21 22 23 24
DPT Interface Connection is Established
Modem Card Initialization Completed
** ON LINE MODE **
    
```

Note

You will see "Modem Card Initialization Completed" only when connecting the KX-TVS325.

The display will alert you if System Setup is not completed successfully.

Screen output:

```

Active COs: 1  2  3  4  5  6  7  8  9 10 11 12
           13 14 15 16 17 18 19 20 21 22 23 24
DPT Interface Connection is not Established
Modem Card Initialization Completed
** OFF LINE MODE **
    
```

This message will appear when the DPT connection between the VPS and telephone system cannot be established.

Possible causes of the message: "DPT Interface Connection is not Established"

Table 4-4

Cause	Remedy
The PBX is not a KX-TD series or KX-TA1232 system. Since the VPS is configured to communicate with the default PBX type at the factory (KX-TD500 for the KX-TVS325; KX-TD1232 for the KX-TVS125 and KX-TVS225), this message will always appear when connecting to another type of PBX.	Connect a KX-TD series or KX-TA1232 PBX and set the PBX type by using Quick Setup (see Section 5 CUSTOMIZING THE SYSTEM).
The cabling between the PBX extension ports and the VPS is not 4-wire or is improperly connected.	Confirm the cabling is connected as described in Section 2 INSTALLATION.
The PBX is a KX-TD series or KX-TA1232 but does not have the proper level of software required to support DPT Integration.	Contact National Parts Center at 1-800-833-9626 or use Inband Integration under hardware settings.
The PBX is not programmed properly to support DPT Integration.	Do required integration programming as described in this chapter.

11. Start up completed.

- a) The Power Indicator light stops blinking when the start-up has been successful. (The delay varies according to the system's condition.)
- b) ****ON LINE MODE**** is displayed.
- c) System prompt [**>**] is displayed on the screen. To enter system administration, **Press ENTER**. All parameters can be set through the menu-driven program.

When the System Administrator starts operation, the system asks for the terminal type. By choosing VT100 [2], all parameters can be set through the menu-driven program.

Please Select Your Terminal Type.
1. ASCII TERMINAL
2. VT100
Please Enter the Number := _____

Please Enter the Number:= [2]

Select [2] because Quick Setup is only available when using a personal computer that can emulate a VT100 terminal.

- 12. Go** to the *System Administration Top Menu*. Select **[5]** and **Press ENTER**, or **Type [3]** then **QSET** and **Press ENTER** for Quick Setup and follow the Auto Configuration Instructions.

TEST: Press the INTERCOM button and then [165]. If the VPS answers, you have a DPT connection.

Set the DIP/Rotary Switch to position 0 after initialization is complete.

The required programming is complete and the VPS and KX-TD1232 should be able to communicate through DPT Integration.

We recommend that the KX-TD1232 system has any optional extension cards installed and telephones connected before starting the VPS.

When running the Quick Setup command (Section 5 CUSTOMIZING THE SYSTEM) from the VPS, the PBX transmits the station information automatically. This saves time when programming the VPS.

4.4.2 KX-TD1232 Software Verification and Programming for DPT Integration via the Operating and Maintenance Tool

Follow these steps after communication between the KX-TD1232 and the programming software has been established. Refer to the Operating and Maintenance manual for connection information.

1. Check the software version.
 - a) Go to the *Main Menu*. Press the **ALT** key and the letter [**V**] at the same time.
 - b) Verify the Operating and Maintenance version being used.

Sample display:

```

Connect DSHS: KX-TD1232
ROM Version: [---P231UxxxxxB] CAN
DB data (PC): Empty
Version: 4.03A5 [0008301332] MUK
  
```

This version must be 4.0xA5 or higher to program the KX-TD1232 for DPT Integration.

Note

If you have an older version of the maintenance tool but have the correct ROM version in the system, you may still program the KX-TD1232 but you must program using the Manager's Extension.

- c) Verify the ROM version of the KX-TD1232.

Example: **P231UYMMDDB**

This version must be at least version P231U or higher for DPT Integration to be utilized (both systems if system connection is being used).

(For KX-TD816, the version must be P301O or higher; for KX-TA1232, the version must be P831AA or higher.)

If the software version of the PBX is lower than this, you may not be able to utilize some of the features available only with DPT Integration. For more information, call National Parts Center at 1-800-833-9626.

In the example above, the underlined digits represent the software production date code (year, month, day).

2. Go to the *Main Menu*. Choose "**System Data Programming**" (BATCH [1] or INTERACTIVE [2]).

Main Menu

1. System Data Programming (BATCH)
 2. System Data Programming (INTERACTIVE)
 3. Disk File Management
 4. DSHS Management
 5. DSHS Connect/Disconnect
 6. Quit
- Select the number : []

3. Choose "**System**" from the *System Data Programming Main Menu*.

System Data Programming Main Menu

1. Line
 2. Station
 - 3. System**
 4. Toll Restriction
 5. ARS
 6. Aux. Ports
 7. Additional Function
 8. Caller ID
- Select the number : [**3**]

4. Choose "**Voice Mail Integration**" from the *System Menu*.

System Menu

- | | |
|-----------------------------------|-----------------------------|
| 01. Day/Night | 14. Opera/Manager/EXT Group |
| 02. Class of Service | 15. Miscellaneous |
| 03. Emergency/Quick Dial | 16. Caller ID Modification |
| 04. Speed Dial | 17. Switch Type |
| 05. Absent Message | 18. DID |
| 06. Flexible Numbering | 19. Lunch/Break Time |
| 07. Account Code | 20. System Time |
| 08. Special Carrier | 21. Version |
| 09. Timer | 22. ISDN Card |
| 10. Voice Mail | 23. T1 Card |
| 11. Voice Mail Integration | 24. T1 Minor Error |
| 12. UCD | |
| 13. Phantom | |

Select the number: [**11**]

- First, **enter the port numbers** that will be connected to the VPS. If desired, change the default extension numbers of the Voice Mail ports.

Voice Mail Integration

VM Port No.		Master <u>30</u> [] [] [] [] [] [] [] []							
		Slave [] [] [] [] [] [] [] []							
VM	Jack	EXT	Name	EXG	VM	Jack	EXT	Name	EXG
01	30-1	[165]	[V.MAIL01]	[1]	13	-1	[171]	[V.MAIL13]	[1]
02	30-2	[166]	[V.MAIL02]	[1]	14	-2	[172]	[V.MAIL14]	[1]
03	-1	[167]	[V.MAIL03]	[1]	15	-1	[173]	[V.MAIL15]	[1]
04	-2	[168]	[V.MAIL04]	[1]	16	-2	[174]	[V.MAIL16]	[1]
05	-1	[169]	[V.MAIL05]	[1]	17	-1	[175]	[V.MAIL17]	[1]
06	-2	[170]	[V.MAIL06]	[1]	18	-2	[176]	[V.MAIL18]	[1]
07	-1	[177]	[V.MAIL07]	[1]	19	-1	[179]	[V.MAIL19]	[1]
08	-2	[178]	[V.MAIL08]	[1]	20	-2	[180]	[V.MAIL20]	[1]
09	-1	[181]	[V.MAIL09]	[1]	21	-1	[185]	[V.MAIL21]	[1]
10	-2	[182]	[V.MAIL10]	[1]	22	-2	[186]	[V.MAIL22]	[1]
11	-1	[183]	[V.MAIL11]	[1]	23	-1	[187]	[V.MAIL23]	[1]
12	-2	[184]	[V.MAIL12]	[1]	24	-2	[188]	[V.MAIL24]	[1]

- Step 6 should only be done if the VPS is going to answer all incoming Central Office lines directly.**

Return to the *System Data Programming Main Menu*. Select **"Line"** and then select **"CO Line Setting 1"**. Program all lines DIL to the first extension of the Voice Mail hunt group.

CO Line Setting

CO No	C O N	T R G	D I A L	D T M F	P S	C I D	CPC Detection Mode Out		DIL 1:1 EXT No Day Night		R E V	DIL 1:1 Lunch Group Break Group	
01	Y	[1]	D	80	10	N	Disable	Disable	<u>EXT[165]</u>	<u>EXT[165]</u>	Reg.	[]	[]
02	Y	[2]	D	80	10	N	Disable	Disable	<u>EXT[165]</u>	<u>EXT[165]</u>	Reg.	[]	[]
03	Y	[3]	D	80	10	N	Disable	Disable	<u>EXT[165]</u>	<u>EXT[165]</u>	Reg.	[]	[]
04	Y	[4]	D	80	10	N	Disable	Disable	<u>EXT[165]</u>	<u>EXT[165]</u>	Reg.	[]	[]
05	Y	[5]	D	80	10	N	Disable	Disable	<u>EXT[165]</u>	<u>EXT[165]</u>	Reg.	[]	[]
06	Y	[6]	D	80	10	N	Disable	Disable	<u>EXT[165]</u>	<u>EXT[165]</u>	Reg.	[]	[]
07	Y	[7]	D	80	10	N	Disable	Disable	<u>EXT[165]</u>	<u>EXT[165]</u>	Reg.	[]	[]
08	Y	[8]	D	80	10	N	Disable	Disable	<u>EXT[165]</u>	<u>EXT[165]</u>	Reg.	[]	[]
09	Y	[8]	D	80	10	N	Disable	Disable	<u>EXT[165]</u>	<u>EXT[165]</u>	Reg.	[]	[]
10	Y	[8]	D	80	10	N	Disable	Disable	<u>EXT[165]</u>	<u>EXT[165]</u>	Reg.	[]	[]
11	Y	[8]	D	80	10	N	Disable	Disable	<u>EXT[165]</u>	<u>EXT[165]</u>	Reg.	[]	[]
12	Y	[8]	D	80	10	N	Disable	Disable	<u>EXT[165]</u>	<u>EXT[165]</u>	Reg.	[]	[]

7. Follow steps 5-12 in 4.4.1 KX-TD1232 Software Verification and Programming for DPT Integration via the Manager's Extension.

The required programming is now complete and the VPS and KX-TD1232 should be able to communicate through DPT Integration.

We recommend that the KX-TD1232 system has any optional extension cards installed and telephones connected before starting the VPS.

When running the Quick Setup command (Section 5 CUSTOMIZING THE SYSTEM) from the VPS, the PBX transmits the station information automatically. This saves time when programming the VPS.

4.4.3 KX-TD308 Software Verification and Programming for DPT Integration via the Manager's Extension

It is important that the KX-TD308 has the proper software level to allow DPT Integration with the VPS. Follow the procedures below to confirm the software level, then complete the required programming before starting up the VPS.

All of the following procedures must be done after entering system programming. Refer to the KX-TD308 Programming Guide or Installation Manual for instructions on how to enter the system programming mode.

Software Verification

1. Verify Software—check the software version of the KX-TD308 using System Program [116].

Example: **P871FYMMDDA**

The underlined digits represent the software production date code (year, month, day). For DPT Integration, the software version of the PBX must be P871F or higher.

If the software version of the PBX is lower than this, you may not be able to utilize some of the features available only with DPT Integration. For more information, call National Parts Center at 1-800-833-9626.

*From the **SYS-PGM NO ?** screen:*

- a) Enter [116].
- b) Press the **NEXT** button (SP-PHONE).
- c) The system displays the ROM version and the date it was created.

This version must be P871F or higher for DPT Integration to be utilized.

2. Set the date and time using System Program [000].
3. Set PBX extension numbering using System Program [003].

4. **Assign the Voice Mail Port.** This program tells the PBX which jack will be connected to the VPS. This allows the PBX to send the proper DPT Integration information to those ports.

Note

You can assign a maximum of 2 jacks (4 ports) with the KX-TD308.

*From the **SYS-PGM NO ?** screen:*

- a) **Enter [117].**
- b) **Press the NEXT button (SP-PHONE).**
Screen output: M: # #
- c) **Enter the jack number (2-8)** of the port you will use for the Voice Mail.
- d) **Press STORE.**
- e) **Press END (HOLD)** when finished.

Conditions: *Jack 01 cannot be used as a Voice Mail port. A jack programmed as a Manager Extension (System Program [006]) cannot be used in this program.*

5. **Skip this step unless setting flexible numbering.**

System Program [118] (Voice Mail Extension Number Assignment) is automatically set. This program allows you to assign an extension number to each Voice Mail port. Since a jack connected to the VPS provides 2 extensions, this enables you to assign extension numbers to each port. You can assign any extension number that is not already assigned to another port. To reach the VPS, users dial these extension numbers. It is not necessary to change the default programming for the extensions 295 and 296.

*From the **SYS-PGM NO ?** screen:*

- a) **Enter [118].**
- b) **Press the NEXT button (SP-PHONE).**
Screen output: VM NO? →
- c) **Press the NEXT button (SP-PHONE).**
Screen output: VM-1: #__ -1: 295
(__ = the port number you entered in program 117)
- d) **Enter the extension number** that you want this port to have.
(The default extension number for port 1: 295; port 2: 296)
- e) **Press STORE.**
- f) Repeat steps c, d, and e until all extension numbers are entered.

Conditions: *No 2 jacks on the system can have the same extension number. If you try to enter a number that is already assigned, you will hear an error tone. Each digital extension connected provides 2 Voice Mail ports and must have 2 different extension numbers assigned.*

6. **Connect the jack** assigned in Step 4 to the VPS.

7. **Connect** your **personal computer** to the VPS and start your communication software (i.e., HyperTerminal, Procomm Plus, Smartcom...).
Communication Parameters: 9600, 8 Bit, None, 1
8. **Turn** the power switch **off** at the VPS and **set** the **DIP/Rotary Switch** to **position 5**.
Only perform this step when initially setting up the system.

CAUTION

Setting the DIP/Rotary Switch to position 5 will default the Voice Processing System, resulting in a loss of all user programming and voice messages (except User 1 and User 2 prompts).

9. **Turn** the power switch back **on** at the VPS and wait approximately 7-8 min while the system initializes.

Before starting the VPS, make sure all installation and line connections have been done as described in Section 2 INSTALLATION.

The calls to the VPS can be processed after the Power Indicator stops flashing.

After turning the power on, the system starts up in the following sequence:

- *The Power Indicator light goes on.*
- *The Power Indicator light begins to flash.*
- *"CARD TEST" is displayed on the screen.*
- *"SYSTEM SETUP" is displayed.*

Screen output:

```

CARD TEST...
SYSTEM SETUP...
  1...  2...  3...  4...  5...  6...  7...  8...  9... 10...
11... 12... 13... 14... 15... 16... 17...
```

- *The VPS tests the CPU board, the hard disk drive, and the CO cards as "SYSTEM SETUP" is displayed.*
- *Active ports are displayed on the screen (the number of active ports depends on the VPS model).*

Screen output:

```

Active COs: 1  2  3  4  5  6  7  8  9 10 11 12
          13 14 15 16 17 18 19 20 21 22 23 24
DPT Interface Connection is Established
Modem Card Initialization Completed
** ON LINE MODE **
```

Note

You will see "Modem Card Initialization Completed" only when connecting the KX-TVS325.

The display will alert you if System Setup is not completed successfully.

Screen output:

```
Active COs: 1  2  3  4  5  6  7  8  9 10 11 12
             13 14 15 16 17 18 19 20 21 22 23 24
DPT Interface Connection is not Established
Modem Card Initialization Completed
** OFF LINE MODE **
```

This message will appear when the DPT connection between the VPS and telephone system cannot be established.

Possible causes of the message: "DPT Interface Connection is not Established"

Table 4-5

Cause	Remedy
The PBX is not a KX-TD series or KX-TA1232 system. Since the VPS is configured to communicate with the default PBX type at the factory (KX-TD500 for the KX-TVS325; KX-TD1232 for the KX-TVS125 and KX-TVS225), this message will always appear when connecting to another type of PBX.	Connect a KX-TD series or KX-TA1232 PBX and set the PBX type by using Quick Setup (see Section 5 CUSTOMIZING THE SYSTEM).
The cabling between the PBX extension ports and the VPS is not 4-wire or is improperly connected.	Confirm the cabling is connected as described in Section 2 INSTALLATION.
The PBX is a KX-TD series or KX-TA1232 but does not have the proper level of software required to support DPT Integration.	Contact National Parts Center at 1-800-833-9626 or use Inband Integration under hardware settings.
The PBX is not programmed properly to support DPT Integration.	Do required integration programming as described in this chapter.

10. Start up completed.

- a) The Power Indicator light stops blinking when the start-up has been successful. (The delay varies according to the system's condition.)
- b) *****ON LINE MODE***** is displayed.
- c) System prompt [**>**] is displayed on the screen. To enter system administration, **Press ENTER**. All parameters can be set through the menu-driven program.

When the System Administrator starts operation, the system asks for the terminal type. By choosing VT100 [2], all parameters can be set through the menu-driven program.

Please Select Your Terminal Type.
1. ASCII TERMINAL
2. VT100
Please Enter the Number := _____

Please Enter the Number:= [2]

Select [2] because Quick Setup is only available when using a personal computer that can emulate a VT100 terminal.

- 11. Go** to the *System Administration Top Menu*. **Select [5]** and **Press ENTER**, or **Type [3]** then **QSET** and **Press ENTER** for Quick Setup and follow the Auto Configuration Instructions.

TEST: Press the INTERCOM button and then [295]. If the VPS answers, you have a DPT connection.

Set the DIP/Rotary Switch to position 0 after initialization is complete.

The required programming is complete and the VPS and KX-TD308 should be able to communicate through DPT Integration.

We recommend that the KX-TD308 system has any optional extension cards installed and telephones connected before starting the VPS.

When running the Quick Setup command (Section 5 CUSTOMIZING THE SYSTEM) from the VPS, the PBX transmits the station information automatically. This saves time when programming the VPS.

4.5 DPT INTEGRATION FEATURES AND SETUP PROCEDURES FOR THE PANASONIC KX-TA1232 AND KX-TD SERIES

The following VPS features are functional on any KX-T7xxx proprietary telephone that works when connected to your PBX.

4.5.1 Live Call Screening (LCS) Programming

LCS notifies subscribers of incoming messages to their mailboxes. The notification method is programmable for hands-free or private. Hands-free allows the user to monitor a recording through the speakerphone and, if desired, intercept the call by lifting the handset. The private mode notifies the user with an alert tone when a message is being recorded. By pressing the LCS button, the user can monitor the message and intercept the call by going off-hook. System Programming or PC Programming (only available for KX-TD500 users) also determines whether the mailbox continues to record after the user intercepts the call.

4.5.2 Live Call Screening Password Assignment

To allow the Live Call Screening feature to work at an extension, the extension must have the LCS button lit. To light this button on the telephone, press the LCS button, then enter the password. This password prevents others from activating the LCS feature and listening to the messages as they are being left. (It is not necessary to enter PITS Programming to activate this feature.)

PC programming is also available for KX-TD500 users (see 4.5.6 Live Call Screening Assignment via PC Programming).

1. **Lift** the handset or **Press** the **SP-PHONE** button.
2. **Dial** the feature number **[799]**.
3. **Enter** a 3-digit password (**[000]-[999]**) twice.
You will hear a confirmation tone, then a dial tone.
Screen output: The 3-digit password you entered is displayed.
4. **Hang up** or **Press** the **SP-PHONE** button.
5. Repeat these steps for each telephone.

4.5.3 Live Call Screening Password Canceling

To cancel the password, follow the procedure below. (It is not necessary to enter PITS Programming to activate this feature).

PC programming is also available for KX-TD500 users (see 4.5.6 Live Call Screening Assignment via PC Programming).

1. **Lift** the handset or **Press** the **SP-PHONE** button.
2. **Dial** the feature number [799].
3. **Enter** the password ([000]-[999]).
You will hear a confirmation tone, then a dial tone.
Screen output: Password Cancel
4. **Hang up** or **Press** the **SP-PHONE** button.
5. Repeat these steps for each telephone.

4.5.4 Live Call Screening Recording Mode Assignment via System Programming

This program allows the VPS to continue recording the conversation in the mailbox after the extension intercepts the call during the Live Call Screening.

PC programming is also available for KX-TD500 users (see 4.5.6 Live Call Screening Assignment via PC Programming).

1. **Enter** [610] from system program.
2. **Press** the **NEXT** button (SP-PHONE).
Screen output: Jack No.? →
3. **Enter** the **jack number**.
Screen output: # _ _ :Stop Rec
(_ _ = the jack number you entered)
4. **Press** the **SELECT** button (AUTO-ANSWER) until the desired selection is displayed.
5. **Press** **STORE**.
6. **Press** the **NEXT** button (SP-PHONE).
7. Repeat the steps 4 to 6 until all jacks are programmed.

4.5.5 Live Call Screening Private/Hands-Free Mode Assignment via Station Programming

This program assigns a VPS response for when a message is being left in a mailbox. It determines whether an alert tone is sent or whether the recorded message is played through the built-in speaker of the extension. The default mode is hands-free. (This is a station level program and should be done at each individual telephone.)

PC programming is also available for KX-TD500 users (see 4.5.6 Live Call Screening Assignment via PC Programming).

1. Enter Station Programming:
 - a. With the phone on-hook, **Press** the **PROGRAM** button.
 - b. **Dial [99]**. (Display changes to PT-PGM Mode.)
2. **Dial** the code for the mode you want this telephone to have.
Hands-Free = **71**
Private = **72**
Screen output: Hands-Free or Private
3. **Press STORE.**
4. To exit the Station Programming mode, **Press** the **PROGRAM** button or lift the handset.
5. Repeat these steps for each telephone.

Conditions: None

A single-line telephone that is connected to the same extension as a proprietary telephone can also be used to monitor an incoming message. Be sure that Live Call Screening on the connected proprietary telephone has been activated. This feature is useful when you are using a cordless telephone. The handset sounds an alert tone to let you know that a message is being recorded. To intercept the call, flash the hook.

4.5.6 Live Call Screening Assignment via PC Programming

The KX-TD500 users can program Live Call Screening features via PC programming. Follow the procedure below to assign each feature.

1. Go to "4-2 Extension Line" screen.

Screen output:

2. Select the "Card No." and "Port No." which you are going to program.
3. In "LCS Settings":
 - a) To set LCS Password, **Enter** a 3-digit number (using "0-9") in "LCS Password".

Note

To cancel the password, erase the 3-digit number

- b) To assign LCS Recording Mode, **Set** "Recording Mode" to "**Keep Rec**" or "**Stop Rec**".
- c) To assign LCS Private/Hands-free Mode, **Set** "Operation Mode" to "**Private**" or "**Hands-free**".
- d) To activate the LCS status, **Set** "Status" to "**Active**".

Note

To utilize the Live Call Screening features, it is necessary to first assign the LCS Password and LCS Button (see 4.5.12 Button Assignment via PC Programming), and then activate the LCS status.

4. Click "Apply".
5. Repeat steps 2 to 4 for each extension.

4.5.7 Live Call Screening Button Assignment via Station Programming

For the Live Call Screening feature to work at an extension, the extension must have an LCS button lit at the time of the message reception. This key must either be a DSS/BLF or CO key with a lamp. Follow the procedure below to assign an LCS button on an extension. (This is a station level program and should be done at each individual telephone.)

PC programming is also available for KX-TD500 users (see 4.5.12 Button Assignment via PC Programming).

1. Enter PITS Programming:
 - a. With the phone on-hook, **Press** the **PROGRAM** button.
 - b. **Dial [99]**. (Display changes to PT-PGM Mode.)
2. **Press** the desired **FLEXIBLE (CO or DSS/BLF)** button you want to assign as the LCS button.
3. **Dial [92]**.
Screen output: LCS
4. **Press STORE**.
5. To exit the Station Programming mode, **Press** the **PROGRAM** button or lift the handset.
6. Repeat these steps for each telephone.

4.5.8 Live Call Screening Cancel Button Assignment via Station Programming

This button assignment allows you to assign a Flexible (CO, DSS) button as a Live Call Screening Cancel button.

PC programming is also available for KX-TD500 users (see 4.5.12 Button Assignment via PC Programming).

1. Enter PITS Programming:
 - a. With the phone on-hook, **Press** the **PROGRAM** button.
 - b. **Dial [99]**. (Display changes to PT-PGM Mode.)
2. **Press** the **Flexible (CO, DSS)** button that you wish to assign as a Live Call Screening Cancel button.
3. **Dial [93]**.
Screen output: LCS Cancel
4. **Press STORE**. The STORE indicator light turns on.
The display shows the initial programming mode.
5. To exit the Station Programming mode, **Press** the **PROGRAM** button or lift the handset.
6. Repeat these steps for each telephone.

The Live Call Screening Cancel Button Assignment is optional; Live Call Screening can also be canceled by **Pressing** the **FLASH** button.

4.5.9 Two-Way Recording Button Assignment via Station Programming

For the Two-Way Recording feature to work at an extension, the extension must have a TWR button on it. This key must either be a DSS/BLF or CO key with a lamp. Follow the procedure below to assign a TWR button on an extension. (This is a station level program and should be done at each individual telephone.)

PC programming is also available for KX-TD500 users (see 4.5.12 Button Assignment via PC Programming).

1. Enter PITS Programming:
 - a. With the phone on-hook, **Press** the **PROGRAM** button.
 - b. **Dial [99]**. (Display changes to PT-PGM Mode.)
2. **Press** the **Flexible** button (**CO** or **DSS/BLF**) that you want to assign as the TWR button.
3. **Dial [90]**.
Screen output: 2Way-Rec:
4. **Dial** the **Voice Mail extension number**.
Screen output: 2Way-Rec: _ _ _
(*_ _ _ = The extension number you entered*).
5. **Press Store**.
6. To exit the Station Programming mode, **Press** the **PROGRAM** button or lift the handset.
7. Repeat these steps for each telephone.

Conditions: *This button must be a CO or DSS/BLF key to be programmed as a TWR button. If this key is pressed when all Voice Mail ports are busy, the user will hear a reorder tone.*

4.5.10 Two-Way Transfer Button Assignment via Station Programming

For the Two-Way Transfer feature to work at an extension, the extension must have a TWT button on it. This key must either be a DSS/BLF or CO key with a lamp. Follow the procedure below to assign a TWT button on an extension. (This is a station level program and should be done at each individual telephone.)

PC programming is also available for KX-TD500 users (see 4.5.12 Button Assignment via PC Programming).

1. Enter PITS Programming:
 - a. With the phone on-hook, **Press** the **PROGRAM** button.
 - b. **Dial [99]**. (Display changes to PT-PGM Mode.)
2. **Press** the desired **FLEXIBLE (CO or DSS/BLF)** button that you want to assign as the TWT button.
3. **Dial [91]**.
Screen output: 2Way-Trans:
4. **Dial the Voice Mail extension number**.
Screen output: 2Way-Trans: _ _ _
(_ _ _ = The extension number you entered).
5. **Press STORE**.
6. To exit the Station Programming mode, **Press** the **PROGRAM** button or lift the handset.
7. Repeat these steps for each telephone.

Conditions: *This button must be a CO or DSS/BLF key to be programmed as a TWT button. When all Voice Mail ports are busy and this key is pressed, the user will hear reorder tone.*

4.5.11 Voice Mail Transfer Button Assignment via Station Programming

This feature allows an extension user to transfer calls directly to a Voice Mailbox. This is available with both DPT and Inband Integrations.

PC programming is also available for KX-TD500 users (see 4.5.12 Button Assignment via PC Programming).

1. Enter PITS Programming:
 - a. With the phone on-hook, **Press** the **PROGRAM** button.
 - b. **Dial [99]**. (Display changes to PT-PGM Mode.)
2. **Press** the desired **Flexible (CO or DSS/BLF)** button that you want to assign as the VTR button.
3. **Dial [8]**.
Screen output: VTR
4. **Dial the Voice Mail extension number**.
Screen output: VTR- _ _ _
(_ _ _ = The extension number you entered).

5. Press **STORE**.
6. To exit the Station Programming mode, Press the **PROGRAM** button or lift the handset.
7. Repeat these steps for each telephone.

Conditions: *This button must be a CO or DSS/BLF key to be programmed as a VTR button. When all Voice Mail ports are busy and this key is pressed, the user will hear reorder tone.*

4.5.12 Button Assignment via PC Programming

The KX-TD500 users can assign buttons via PC programming. Follow the procedure below to assign each button.

1. Go to "4-2 Extension Line" screen (refer to the screen image in 4.5.6 Live Call Screening Assignment via PC Programming).
2. Select the "Card No." and "Port No." which you are going to program.
3. Click "CO Key" in the upper right corner. "Flexible CO Key" screen (for all CO Keys) displays.
Screen output:

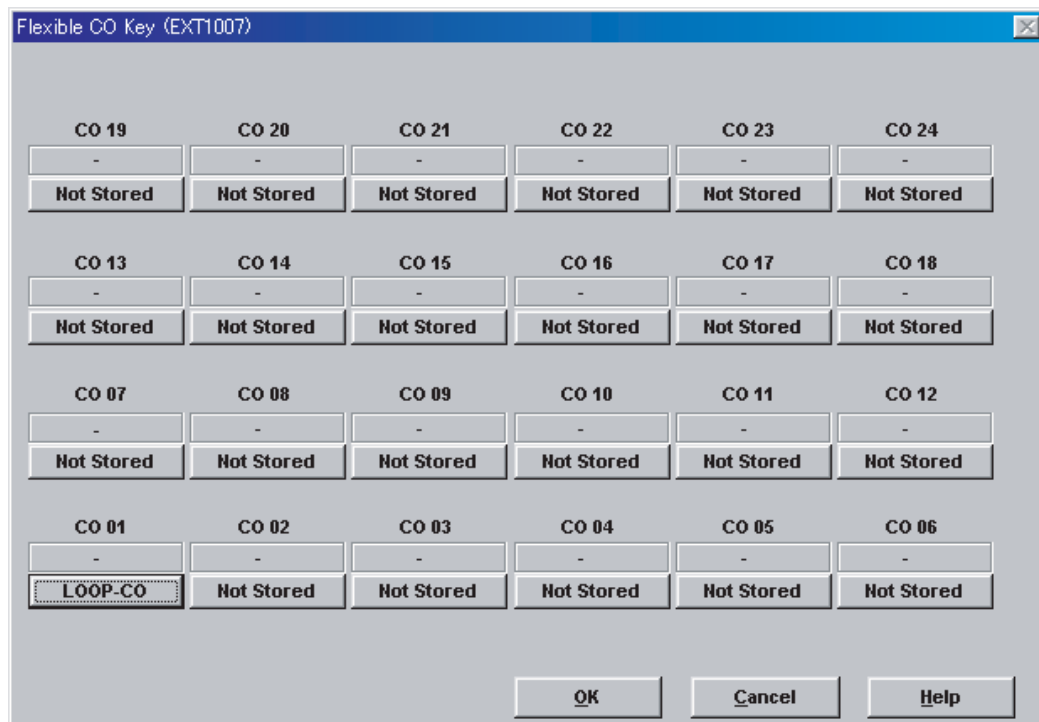

4. Click the **Key Number** to which a button will be assigned. "Flexible CO Key" screen displays.
Screen output:

Flexible CO Key

10 Key Type: Not Stored

EXT.: []

Trunk Line No.: []

Dial: []

Tone: 2

Ringing Type: Immediate

OK Cancel Help

5. Select the desired **Key Type**. When 2WAY-REC, 2WAY-TRN, or VTR is selected, enter the **extension number** in "DN".
Example screen output:

Flexible CO Key

10 Key Type: 2WAY-TRN

DN: []

Trunk Line No.: []

Dial: []

Tone: 2

Ringing Type: Immediate

OK Cancel Help

6. Click "OK". "Flexible CO Key" screen (for all CO Keys) displays again.
7. Click "OK". "4-2 Extension Line" screen displays again.
8. Click "OK" or "Apply".
9. Repeat these steps for each extension.

4.5.13 Live Call Screening Activation

To activate the Live Call Screening status, follow the steps below. PC programming is also available for KX-TD500 users (see 4.5.6 Live Call Screening Assignment via PC Programming).

1. **Press** the assigned **LCS Button**.
2. **Press** the assigned **LCS Password**.
3. Confirm the assigned **LCS Button** is red-on.
4. Repeat these steps for each telephone.

Conditions: *To activate the Live Call Screening features, it is necessary to light the LCS button after assigning the LCS password and LCS button.*

4.5.14 Live Call Screening Password Control

This feature allows Operator(s) and the Manager of the PBX to cancel the password for LCS at any extension. If a user forgets the preprogrammed password, Operator(s) and the Manager of the PBX can cancel the LCS password.

1. Enter PITS Programming:
 - a. With the phone on-hook, **Press** the **PROGRAM** button.
 - b. **Dial [99]**. (Display changes to PT-PGM Mode.)
2. **Dial [03]**.
Screen output: Ext NO?
3. **Dial** the desired **Extension Number**, or **Press** [*****] to remove all passwords.
4. **Press STORE**.
5. To exit the Station Programming mode, **Press** the **PROGRAM** button or lift the handset.
6. Repeat these steps for each telephone.

4.5.15 Two-Way Recording into Mailbox

This feature allows extension users to record conversations into their mailboxes by pressing the Two-Way Recording (TWR) button.

4.5.16 Two-Way Transfer into Mailbox

This feature allows an extension user to record a conversation into another person's mailbox by pressing the Two-Way Transfer (TWT) button and dialing the mailbox number. This is commonly used by a person who is taking a detailed message for someone else and wants the message recorded in the mailbox at the same time.

4.5.17 A Restriction on TWR/TWT Activation

If your PBX is a basic KX-TD500, you can have only 8 simultaneous activations of Two-Way Recording and Two-Way Transfer, because the basic KX-TD500 supports only 8 three-way conferences. However, if you add the KX-TD50104 TSW-CONF (TSW Conference Expansion) Card to your PBX, then the PBX supports an additional 64 three-way conferences. In this case, the PBX will not limit the VPS on Two-Way conversation recordings.

4.6 DPT INTEGRATION FEATURES AND SETUP PROCEDURES FOR THE PANASONIC KX-TDA/KX-TAW SERIES PBX

The following VPS features are functional on any KX-T7xxx proprietary telephone that works when connected to your PBX.

4.6.1 Live Call Screening (LCS) Programming

LCS notifies subscribers of incoming messages to their mailboxes. The notification method is programmable for hands-free or private. Hands-free allows the user to monitor a recording through the speakerphone and, if desired, intercept the call by lifting the handset. The private mode notifies the user with an alert tone when a message is being recorded. By pressing the LCS button, the user can monitor the message and intercept the call by going off-hook. System Programming also determines whether the mailbox continues to record after the user intercepts the call.

4.6.2 Live Call Screening Password Assignment

To allow the Live Call Screening feature to work at an extension, the extension must have the LCS button lit. To light this button on the phone, press the LCS button, then enter the password. This password prevents others from activating the LCS feature and listening to the messages as they are being left. (It is not necessary to enter Station Programming to activate this feature.) PC programming is also available (see 4.6.6 Live Call Screening Assignment via PC Programming).

Note

The term "Live Call Screening Password", used in KX-TA/KX-TD series PBXs, has the same meaning as "Extension PIN (Personal Identification Number)" used in KX-TDA/KX-TAW series PBXs. For more information, refer to the KX-TDA/KX-TAW series manuals.

1. **Lift** the handset or **Press** the **SP-PHONE** button.
2. **Press** the feature number [***799**].
3. Press [**1**].
Screen output: Enter PIN
4. **Enter** any password of maximum 10 digits and [#].
Screen output: Enter PIN Again
5. **Enter** same password of maximum 10 digits and [#].
You will hear a confirmation tone, then a dial tone.
Screen output: PIN set
6. **Hang up** or **Press** the **SP-PHONE** button.

4.6.3 Live Call Screening Password Canceling

To cancel the password, follow the procedure below. (It is not necessary to enter Station Programming to activate this feature). PC programming is also available (see 4.6.6 Live Call Screening Assignment via PC Programming).

Note

The term "Live Call Screening Password", used in KX-TA/KX-TD series PBXs, has the same meaning as "Extension PIN (Personal Identification Number)" used in KX-TDA/KX-TAW series PBXs. For more information, refer to the KX-TDA/KX-TAW series manuals.

1. **Lift** the handset or **Press** the **SP-PHONE** button.
2. **Press** the feature number [***799**].
3. Press [**0**].
Screen output: Enter PIN
4. **Enter** the stored password of maximum 10 digits.
You will hear a confirmation tone, then a dial tone.
Screen output: PIN cleared
5. **Hang up** or **Press** the **SP-PHONE** button.

4.6.4 Live Call Screening Recording Mode Assignment

This program allows the VPS to continue recording the conversation in the mailbox after the extension intercepts the call during the Live Call Screening. (This is station level programming and should be done at each individual phone.)

1. Enter Station (Personal) Programming:
With the phone on-hook, **Press** the **PROGRAM** button.
(Display changes to PT-PGM Mode.)
2. Enter [**26**].
Screen output: Rec. after LCS
3. **Press** the **ENTER** button.
4. **Press** the **SELECT** button (AUTO ANSWER) until the desired selection is displayed.
Screen output: Stop Record/Keep Record
5. **Press** **STORE**.
6. **Press** the **PROGRAM** button or lift the handset to exit the Station (Personal) Programming mode.
7. Repeat these steps for each telephone.

4.6.5 Live Call Screening Private/Hands-Free Mode Assignment

This program assigns a VPS response for when a message is being left in a mailbox. It determines whether an alert tone is sent and whether the recorded message is played through the built-in speaker of the extension. The default mode is hands-free. (This is station level programming and should be done at each individual phone.) PC programming is also available (see 4.6.6 Live Call Screening Assignment via PC Programming).

1. Enter Station (Personal) Programming:
With the phone on-hook, **Press** the **PROGRAM** button.
(Display changes to PT-PGM Mode.)
2. Enter **[25]**.
Screen output: LCS Private
3. **Press** the **ENTER** button.
4. **Press** the **SELECT** button until the desired selection is displayed.
Screen output: Hands-Free/Private
5. **Press** **STORE**.
6. **Press** the **PROGRAM** button or lift the handset to exit the Station (Personal) Programming mode.
7. Repeat these steps for each telephone.

A single-line telephone that is connected to the same extension as a proprietary telephone can also be used to monitor an incoming message. Be sure that Live Call Screening on the connected proprietary telephone has been activated. This feature is useful when you are using a cordless telephone. The handset sounds an alert tone to let you know that a message is being recorded. To intercept the call, hang up and go off-hook.

4.6.6 Live Call Screening Assignment via PC Programming

The KX-TDA/KX-TAW series users can program Live Call Screening features via PC programming. Follow the procedure below to assign each feature.

1. Go to "4.Extension-1.Wired Extension-1.Extension Settings" screen.

Screen output:

Slot	Port	Extension Number	Extension Name (20 characters)	Call Waiting Tone Type	LCS Recording Mode	LCS Answer Mode	Display Language
01	01	101	Operator	CW Tone 1	Keep Record	Private	Language1
01	02	102		CW Tone 1	Stop Record	Hands free	Language1
01	03	103		CW Tone 1	Stop Record	Hands free	Language1
01	04	104		CW Tone 1	Stop Record	Hands free	Language1
01	05	105		CW Tone 1	Stop Record	Hands free	Language1
01	06	106		CW Tone 1	Stop Record	Hands free	Language1
01	07	107		CW Tone 1	Stop Record	Hands free	Language1
01	08	108		CW Tone 1	Stop Record	Hands free	Language1
01	XDP01	201		CW Tone 1	Stop Record	Hands free	Language1
01	XDP02	202		CW Tone 1	Stop Record	Hands free	Language1
01	XDP03	203		CW Tone 1	Stop Record	Hands free	Language1

Note

The above screen output is an example of the KX-TDA200.

2. Select "Option 4" window of the extension for which you want to program.
3. Assign LCS Recording Mode to "Keep Record" or "Stop Record".
4. Assign LCS Answer Mode to "Hands free" or "Private".
5. Click "Apply" to save the changed data.

4.6.7 Live Call Screening Button Assignment

For the Live Call Screening feature to work at an extension, the extension must have an LCS button on it and the button must be lit at the time of the message reception. This button must either be a DSS/BLF or CO button with a lamp. Follow the procedure below to assign an LCS button on an extension. (This is station level programming and should be done at each individual phone.) PC programming is also available (see 4.6.6 Live Call Screening Assignment via PC Programming).

1. Enter Station (Personal) Programming:
With the phone on-hook, **Press** the **PROGRAM** button.
(Display changes to PT-PGM Mode.)
2. **Press** the desired **Flexible (CO or DSS/BLF)** button you want to assign as the LCS button.
3. **Press [92]**.
Screen output: LCS
4. **Press STORE.**
5. **Press** the **PROGRAM** button or lift the handset to exit the Station (Personal) Programming mode.
6. Repeat these steps for each telephone.

Conditions: *This button must be assigned and lit for LCS to operate. To light this, press the button and enter the LCS password (see 4.6.2 Live Call Screening Password Assignment).*

4.6.8 Two-Way Recording (TWR) Button Assignment

For the Two-Way Recording feature to work at an extension, the extension must have a TWR button on it. This button must either be a DSS/BLF or CO button with a lamp. Follow the procedure below to assign a TWR button on an extension. (This is station level programming and should be done at each individual phone.) PC programming is also available (see 4.6.12 Button Assignment via PC Programming).

1. Enter Station (Personal) Programming:
With the phone on-hook, **Press** the **PROGRAM** button.
(Display changes to PT-PGM Mode.)
2. **Press** the desired **Flexible (CO or DSS/BLF)** button that you want to assign as the TWR button.
3. **Press [90]**.
Screen output: 2WAY-REC-
4. **Enter** a Voice Mail floating extension number.
Screen output: 2WAY-REC- _ _ _
(_ _ _ = The Voice Mail floating extension number you entered).
5. **Press STORE**.
6. **Press** the **PROGRAM** button or lift the handset to exit the Station (Personal) Programming mode.
7. Repeat these steps for each telephone.

Conditions: *This button must be a flexible (CO or DSS/BLF) button to be programmed as a TWR button. When all Voice Mail ports are busy and this key is pressed, the user will hear reorder tone.*

4.6.9 Two-Way Transfer (TWT) Button Assignment

For the Two-Way Transfer feature to work at an extension, the extension must have a TWT button on it. This button must either be a DSS/BLF or CO button with a lamp. Follow the procedure below to assign a TWT button on an extension. (This is station level programming and should be done at each individual phone.) PC programming is also available (see 4.6.12 Button Assignment via PC Programming).

1. Enter Station (Personal) Programming:
With the phone on-hook, **Press** the **PROGRAM** button.
(Display changes to PT-PGM Mode.)
2. **Press** the desired **Flexible (CO or DSS/BLF)** button that you want to assign as the TWT button.
3. **Press [91]**.
Screen output: 2WAY-Xfr-
4. **Enter** a Voice Mail floating extension number.
Screen output: 2WAY-Xfr- _ _ _
(_ _ _ = The Voice Mail floating extension number you entered).
5. **Press STORE**.

6. Press the **PROGRAM** button or lift the handset to exit the Station (Personal) Programming mode.
7. Repeat these steps for each telephone.

Conditions: *This button must be a flexible (CO or DSS/BLF) button to be programmed as a TWT button. When all Voice Mail ports are busy and this key is pressed, the user will hear reorder tone.*

4.6.10 One-Touch Two-Way Transfer (One-Touch TWT) Button Assignment

For the One-Touch Two-Way Transfer feature to work at an extension, the extension must have a One-Touch TWT button on it. This button must either be a DSS/BLF or CO button with a lamp. Follow the procedure below to assign a One-Touch TWT button on an extension. (This is station level programming and should be done at each individual phone.) PC programming is also available (see 4.6.12 Button Assignment via PC Programming).

1. Enter Station (Personal) Programming:
With the phone on-hook, **Press** the **PROGRAM** button.
(Display changes to PT-PGM Mode.)
2. **Press** the desired **Flexible (CO or DSS/BLF)** button you want to assign as the One-Touch TWT button.
3. **Press [91]**.
Screen output: 2WAY-Xfr-
4. **Enter** a Voice Mail floating extension number.
Screen output: 2WAY-Xfr- _ _ _
(_ _ _ = The Voice Mail floating extension number you entered).
5. **Press [#]**.
6. **Enter** a Transferred extension number.
Screen output: 2WAY-Xfr- _ _ _ # _ _ _
(# _ _ _ = The Transferred extension number you entered).
7. **Press STORE**.
8. **Press** the **PROGRAM** button or lift the handset to exit the Station (Personal) Programming mode.
9. Repeat these steps for each telephone.

Conditions: ***This button must be a flexible (CO or DSS/BLF) button to be programmed as a One-Touch TWT button. When all Voice Mail ports are busy and this key is pressed, the user will hear reorder tone.***

4.6.11 Voice Mail Transfer (VTR) Button Assignment

For the Voice Mail Transfer feature to work at an extension, the extension must have the VTR button. This button must either be a DSS/BLF or CO button with a lamp. Follow the procedure below to assign a VTR button on an extension. (This is station level programming and should be done at each individual phone.) PC programming is also available (see 4.6.12 Button Assignment via PC Programming).

1. Enter Station (Personal) Programming:
With the phone on-hook, **Press** the **PROGRAM** button.
(Display changes to PT-PGM Mode.)
2. **Press** the desired **Flexible (CO or DSS/BLF)** button that you want to assign as the VTR button.
3. **Press [94]**.
Screen output: VTR-
4. **Enter** a Voice Mail floating extension number.
Screen output: VTR- _ _ _
(_ _ _ = The Voice Mail floating extension number you entered).
5. **Press STORE.**
6. **Press** the **PROGRAM** button or lift the handset to exit the Station (Personal) Programming mode.
7. Repeat these steps for each telephone.

Conditions: *This button must be a flexible (CO or DSS/BLF) button to be programmed as a VTR button. When all Voice Mail ports are busy and this key is pressed, the user will hear reorder tone.*

4.6.12 Button Assignment via PC Programming

The KX-TDA/KX-TAW series users can assign buttons for Two-Way Recording (TWR), Two-Way Transfer (TWT), and Voice Mail Transfer (VTR) via PC Programming. Follow the procedure below to assign each button.

1. **Go** to "4.Extension-1.Wired Extension-4.Flexible Key" screen.

Screen output:

Key Location	Type	Parameter Selection	Ext No. or Floating Ext No.	Dial (Max. 32 digits)	Optional parameter (or Ringing Tone Type Number)	Extension Number of Mailbox
1	Single CO	1			1	
2	Single CO	2			1	
3	Two-way Record		200			
4	Two-way Transfer		200			
5	Two-way Transfer		200			102
6	LCS					
7	Voice Mail Transfer		200			
8	Single CO	8			1	
9	Single CO	9			1	

Note

The above screen output is an example of the KX-TDA200.

2. Select "Extension Number / Name" for which you want to program.
3. Select the desired Key Type for any key which you want to program. When "Two-Way Record", "Two-Way Transfer" or "Voice Mail Transfer" is selected, enter the VM Port floating extension number in "Ext No. or Floating Ext No.". When "Two-Way Transfer" is selected, you can enter the mailbox number of a desired destination under "Extension Number of Mailbox". If no mailbox number is assigned, you will have to enter a mailbox number each time you use the Two-Way Transfer feature.
4. Repeat these steps for each extension.
5. Click "Apply" to save the changed data.

4.6.13 Live Call Screening Activation

To activate the Live Call Screening status, follow the steps below. PC programming is also available (see 4.6.7 Live Call Screening Button Assignment and 4.6.12 Button Assignment via PC Programming).

1. Press the assigned **LCS Button**.
2. Enter the assigned **LCS Password**.
3. Confirm the assigned **LCS Button** is red-on.
4. Repeat these steps for each telephone.

Conditions: To activate the Live Call Screening features, it is necessary to light the LCS button after assigning the LCS password and LCS button.

4.6.14 Two-Way Recording (TWR) into Mailbox

This feature allows extension users to record conversations into their own mailboxes by pressing the Two-Way Recording (TWR) button.

4.6.15 Two-Way Transfer (TWT) into Mailbox

This feature allows an extension user to record a conversation into another person's mailbox by pressing the Two-Way Transfer (TWT) button and dialing the mailbox number. This is commonly used by a person who is taking a detailed message for someone else and wants the message recorded in the mailbox at the same time.

4.6.16 One-Touch Two-Way Transfer (One-Touch TWT) into Mailbox

This feature allows an extension user to record a conversation into another person's mailbox by pressing the One-Touch Two-Way Transfer (One-Touch TWT) button. This is commonly used by a person who is taking a detailed message for someone else and wants the message recorded in the mailbox at the same time.

4.6.17 Voice Mail Transfer (VTR) Programming

This feature allows extension users to transfer calls directly to a Voice Mailbox. This is available with APT/DPT and Inband Integrations.

Section 5
CUSTOMIZING THE SYSTEM

5.1 STARTING UP

5.1.1 Before Programming

1. Determine the customer's needs.
 - *Work with the owner, manager, and receptionist to build the Custom Service Greetings and Holiday Greetings.*
 - *Figure out which ports are to be answered by which greetings.*
 - *Check the software level of the PBX.*
2. Use "System Administration" and your personal computer for the startup sequence.
3. After the system becomes "on line", disconnect the CO lines going into the system until the greetings have been completed.
4. Work with the receptionist to record the system greetings. These are listed in Appendix D6 RECORDING MESSAGES.
 - *It is important to spend time training the receptionist. Making sure that the receptionist understands the system and is capable of answering basic questions will save you time in the end.*
 - *Show the receptionist how to transfer "General Delivery Mailbox" messages. See Appendix D2 MANAGING THE GENERAL DELIVERY MAILBOX.*

5.1.2 Quick Setup

Quick Setup provides a quick way to set the following programming items. Each of these must be initially set to start the VPS operation.

Notes

- Quick Setup requires VT100 emulation software.
 - Quick Setup cannot be performed in ASCII mode.
1. *PBX type*
 2. *Extension numbers of VPS ports*
 3. *Extension names and numbers for mailboxes*
 4. *Creating mailboxes*
 5. *Port service setting*
 6. *Password setting*
 7. *Date and time setting*
 8. *Activating the Quick Setup*

Depending on your PBX type, some steps will be skipped as shown below.

Table 5-1

PBX Type	Required Procedures
KX-T308/T616	1→2→3→4→5→6→7→8
KX-T1232/TA624/ T336/T96*	1→3→4→5→6→7→8
Non-Panasonic System	1→3→4→5→6→7→8
KX-TD816/TD1232/TA1232/TD500/TD308/TDA series/TAW series	1→4→5→6→8

* Not available in the United States.

5.1.3 Starting the Quick Setup

The sequence must be followed through to the end to take effect. If you press "\", you will have to start over. Quick setup may be performed again without erasing prior data.

Notes

- The screen samples given in this section are for the KX-TVS325; if your VPS model is the KX-TVS125 or KX-TVS225, some of the screens may look different.
- Depending on PBX extension numbering, the mailbox numbers might be 2- to 5-digit long.

At the *System Administration Top Menu*, **Type [5]** and **Press ENTER**, or **Type [3]** then **QSET** and **Press ENTER**. See 7.2.17 Quick Setup (QSET) for more information.

Screen output:

System Administration Top Menu → 5

or

System Administration Top Menu → 3 → QSET

Quick Setup Utility for connection to Panasonic KX-T series telephone systems

This utility provides a quick way of programming the Voice Processing System to operate in a standard automated attendant or voice mail configuration when connected to a Panasonic KX-T series telephone system. The system will prompt you to enter, modify or confirm settings based upon which PBX type you select.

By entering the appropriate information in the following screens, the system sets PBX integration parameters, identifies the extension numbers connected to it, creates default mailboxes, sets its ports to handle callers with automated attendant or voice mail service, sets system passwords and sets the time and date. Finally, it confirms if you want to activate the system based on the information you entered, modified or confirmed.

To proceed, press Enter. To exit and cancel Quick Setup now, press \ .

1. PBX Type

a) Press ENTER.

Screen output:

Quick Setup - PBX type
 Please select your PBX type.

1. KX-T308
2. KX-T616
3. KX-T1232/TA624
4. KX-T96
5. KX-T336
6. KX-TD816
7. KX-TD1232/KX-TA1232
8. KX-TD500
9. KX-TD308
- A. KX-TDA/TAW series
0. OTHERS

b) Select your PBX type. The required steps are different for some models. Go to the step indicated below for that type.

Table 5-2

1. KX-T308, 2. KX-T616	Go to Step 2.
3. KX-T1232/KX-TA624, 4. KX-T96, 5. KX-T336, 0. Others	Go to Step 3.
6. KX-TD816, 7. KX-TD1232/KX-TA1232, 8. KX-TD500, 9. KX-TD308, A. KX-TDA/TAW series	Go to Step 4.

Notes

- DPT Integration with the KX-TD816, KX-TD1232/KX-TA1232, KX-TD500, KX-TD308, or KX-TDA/KX-TAW series will be activated automatically by selecting "6. KX-TD816", "7. KX-TD1232/KX-TA1232", "8. KX-TD500", "9. KX-TD308", or "A.KX-TDA/TAW series".
- DPT Integration provides a quicker way to create mailboxes and set the time and date by transferring extension names/numbers and time information from the PBX automatically.

2. Extension Numbers of VPS Ports

Screen output:

Quick Setup - Enter extension number of VPS Port
 Please enter extension number of VPS.

1:	2:	3:	4:	5:	6:
7:	8:	9:	10:	11:	12:
13:	14:	15:	16:	17:	18:
19:	20:	21:	22:	23:	24:

Please enter extension numbers.
 (2 digits) : =
 S: Next Screen

Enter extension numbers of VPS ports with 2-digit numbers. This improves the VPS integration with the KX-T308 or KX-T616 by allowing the VPS to discriminate between VPS extensions and non-VPS extensions.

Type **[S]** to go to the next screen.

Note

The maximum number of VPS ports depends on the VPS model.

3. Extension Numbers for Mailboxes

Screen output:

Quick Setup - Enter Extensions for Mailboxes				
What extensions need a mailbox on this system?				
1:	2:	3:	4:	5:
6:	7:	8:	9:	10:
11:	12:	13:	14:	15:
16:	17:	18:	19:	20:
21:	22:	23:	24:	25:
26:	27:	28:	29:	30:
31:	32:	33:	34:	35:
36:	37:	38:	39:	40:
41:	42:	43:	44:	45:
46:	47:	48:	49:	50:
51:	52:	53:	54:	55:
56:	57:	58:	59:	60:
61:	62:	63:	64:	
<u>Please enter extension numbers.</u>				
: =				
P: Previous menu, N: Next menu, S: Next Screen				

Enter extension numbers of subscribers who need personal mailboxes (the VPS accepts any extension numbers within a 2- to 5-digit range). For example, to enter the extension number 1001, **Press [1001]** and **Press ENTER**. You can also enter multiple extensions. Enter the extensions from No.1001 to No.1010 by **Pressing [1001-1010]** and **Pressing ENTER**.

The VPS will create mailboxes with the extension numbers entered. (See Step 4.)

Note

The maximum number of mailboxes depends on the VPS model.

- With the KX-TVS125, a maximum of 62 extension numbers can be entered.
- With the KX-TVS225 and KX-TVS325, a maximum of 1022 extension numbers can be entered.

4. Creating Mailboxes

To go to the next screen (S) or to change the menu (P or N), the cursor must be in the MBX column.

Screen output:

Quick Setup - Mailbox Editing				Page 1/2
Extension and mailbox list		Assigned 17	Vacant 1005	
EXTN.	MBX	OWNER (Last Name)	MAKE (Make/Delete)	
•••	: 9001	Smith	••••••••••	Make
1002	: 1002	Jones	••••••••••	Make
1003	: 1003	••••••••••	••••••••••	Make
1004	: 1004	••••••~	••••••~	Make
1005	: 1005	••••••~	••••~	Make
1006	: 1006	••••~	••••~	Make
2007	: 2007	••••~	••••~	Make
1008	: 1008	••••~	••••~	Make
1009	: 1009	••••~	••••~	Make
1010	: 1010	••••~	••••~	Make
1011	: 1011	••••~	••••~	Make
1012	: 1012	••••~	••••~	Make
1013	: 1013	••••~	••••~	Make
1014	: 1014	••••~	••••~	Make
1015	: 1015	••••~	••••~	Make

P: Previous menu, N: Next menu, S: Next Screen

a) To create or discard mailboxes

In the "MAKE (Make/Delete)" field: **Type [M]** (Make) to create the mailbox; **Type [D]** (Delete) to discard the mailbox. If there are more than 1022 (or 62, with the KX-TVS125) mailboxes, the first 1022 (or 62) of them are displayed with "Make" and the rest are displayed with "Delete" (screen output: [Assigned 1022 (62), Vacant 0]).

To change the status of a mailbox from "Delete" to "Make", first change the status of a mailbox from "Make" to "Delete" (screen output: [Assigned 1021 (61), Vacant 1]). Then change the status from "Delete" to "Make".

b) Owner's last name

Up to 16 alphabetic characters can be assigned as an Owner's Last Name.

Notes

- Mailbox numbers displayed on this screen**
Panasonic KX-TD/KX-TDA/KX-TAW Series or KX-TA1232 System
 The same numbers as the extensions of the PBX that were automatically transmitted to the VPS—Auto Configuration.
Other Systems
 The same numbers as those of the extensions entered in step 3.
- Mailbox Owner's Last Name**
Panasonic KX-TDA/KX-TAW Series (Version 1.0 or higher) or KX-TD500 (V4M or higher) only
 The same names as the extensions of the PBX that were automatically

transmitted to the VPS—Auto Configuration. When you create mailboxes, you can use the transmitted names as Owner's Last Names, or edit them (Max. 16 characters).

- **The length of mailbox numbers**

The Message Manager mailbox (General Delivery Mailbox) might be 2- to 5-digit long (98, 998, 9998, or 99998).

The System Manager mailbox might be 2- to 5-digit long (99, 999, 9999, or 99999).

If both 3 and 4-digit extension numbers exist at the same time, the VPS will unify all mailbox numbers to 4-digit length by entering [0] at the end of all 3-digit numbers.

Example:

<i>Extension Numbers</i>	<i>Mailbox Numbers</i>
<i>201</i>	<i>201(0) *</i>
<i>202</i>	<i>202(0) *</i>
<i>203</i>	<i>203(0)*</i>
<i>2000</i>	<i>2000</i>
<i>2001</i>	<i>2001</i>
<i>2002</i>	<i>2002</i>

**The VPS puts [0] at the end of 3-digit numbers.*

Note

After creating mailboxes for subscribers by Quick Setup, the COS parameter "Authorization for Message Notification" (see Table B-7 in B3 SYSTEM ADMINISTRATION—SETTING COS (CLASS OF SERVICE) PARAMETERS) for COS number 1 will be set to "Yes". It will stay "No" for COS number 2 through number 62.

To program mailbox parameters other than the extension numbers and Owner's Last Name (or First Name), see 5.5 SETTING MAILBOXES. The caller can use "Dial by Name" feature using the Owner's Last Name when in Automated Attendant Service or Voice Mail Service.

5. Port Service Setting

Screen output:

```

Quick Setup- Port Service Setting
All ports are currently set up to handle callers with standard automated attend-
ant operation, day and night mode, using the Custom Service feature (Custom
1). You can change the operation to standard voice mail (Custom 2) or leave it
as automated attendant. If necessary, Custom 1 and Custom 2 can be modified
under the menu 'Program -> Service Setting -> Custom Service'.

          Day Mode                Night Mode
PORT 1   Auto. Attend.            Auto. Attend.
PORT 2   Auto. Attend.            Auto. Attend.
PORT 3   Auto. Attend.            Auto. Attend.
PORT 4   Auto. Attend.            Auto. Attend.
PORT 5   Auto. Attend.            Auto. Attend.
PORT 6   Auto. Attend.            Auto. Attend.
PORT 7   Auto. Attend.            Auto. Attend.
PORT 8   Auto. Attend.            Auto. Attend.
PORT 9   Auto. Attend.            Auto. Attend.
PORT 10  Auto. Attend.            Auto. Attend.
PORT 11  Auto. Attend.            Auto. Attend.
PORT 12  Auto. Attend.            Auto. Attend.

          A: Auto. Attend., V: Voice Mail
Auto. Attend. (using Custom 1), Voice Mail (using Custom 2)
P: Previous Menu, N: Next Menu, S: Next Screen
    
```

Incoming Call Services for all ports (Day/Night) can be defined by this setting. Default values for all ports (Day/Night) are "Automated Attendant Service (Custom 1)". To select other incoming call services, go to "Setting Ports".

Note

The maximum number of ports depends on the VPS model.

6. Password Setting

Screen output:

```

Quick Setup-Password Setting
System Administrator Password
(Maximum 10 characters)
NEW PASSWORD : =
VERIFICATION : =
System Reset/Clear Password
(Maximum 10 characters)
NEW PASSWORD : =
VERIFICATION : =
    
```

You can assign the System Administrator Password and System Reset/Clear Password in this screen, if necessary.

IMPORTANT

- **We strongly recommend that you set the password to 10 characters for maximum protection against hackers.**
- **Do not carelessly reveal the password to other persons.**
- **Please change the password periodically (for instructions, see 7.2.3 Set Password (PASS) in 7.2 UTILITY COMMANDS.)**

To go to the next screen without assigning the password, **Press ENTER**.

7. Date and Time Setting

Screen output:

```
Quick Setup-Time Setting
  Current time is 3:04, PM
    Enter new time (HH:MM, AM/PM) : =
  Current date is MON JAN-1-2001
    Enter new date (MM-DD-YY) : =
```

Enter the time (hour, minute in 2 digits, comma and A or P) and date (month, day and year in 2 digits).

To go to the next screen, **Press ENTER**.

8. Activating the Quick Setup

Screen output:

```
Quick Setup - Setup
To set up the mailbox and restart, select 'Yes.'
To cancel and exit, select 'No.'
1: Yes      2: No
```

To activate the Quick Setup, **Press [1]** and **Press ENTER**.

Note

To cancel the Quick Setup, Press [2] and Press ENTER. This cancels all changes made up to this point.

The VPS begins to change system programming data.

Screen output:

```
Quick-Setup
  To set up the mailbox and restart, select "Yes."
  To cancel and exit, select "No."
    1: Yes      2: No
      Setup 9998...
```

Then "CARD TEST..." "SYSTEM SETUP..." and "1...2...3..." appear on the screen one by one.

Note

(KX-TVS325 only)

When activating the Quick Setup remotely through the internal modem, the line will be disconnected because the VPS will automatically restart upon finishing the Quick Setup. Please re-establish remote access to the VPS via the internal modem.

Screen output:

```
CARD TEST ...  
SYSTEM SETUP ...  
1 ... 2 ... 3 ...
```

Screen output when Quick Setup is finished:

```
**ON LINE MODE**  
>
```

5.2 PORT SETTING OPTIONS

Design each system according to the needs of your customer. You should be familiar with all options for port assignment so that customers get exactly what they need and expect. Each port can be assigned as Voice Mail, Interview Service, Automated Attendant, or Custom Service. Custom Service is the most flexible of all the services because it allows access to the other services by pressing one key. **We recommend programming all ports as Custom Service for caller convenience.**

5.2.1 Custom Service Setting Example

Custom Service incorporates all features of the Automated Attendant and Voice Mail. Custom Service offers callers a menu of single digits that they may use to reach the desired location quickly and easily.

Sample Company Greeting 1

"Thank you for calling ABC company". (Company greeting should be short!)

Sample Custom Service Message

"If you know the extension number of the person you are calling, you can dial it at any time. For a list of extensions, Press [1]; to reach the sales section, Press [2]; to reach the service section, Press [3]; if you would like to place an order, Press [4]; all other callers, please wait and an operator will be right with you".

Sample Custom Service Tree

Create a tree to design a route that leads callers to the desired extension, mailbox, or next menu. This tree should include all available caller options and cannot be deeper than 8 layers. Moreover, callers cannot jump between Custom Service menus more than 8 times. Discuss available options with the customer before programming the system.

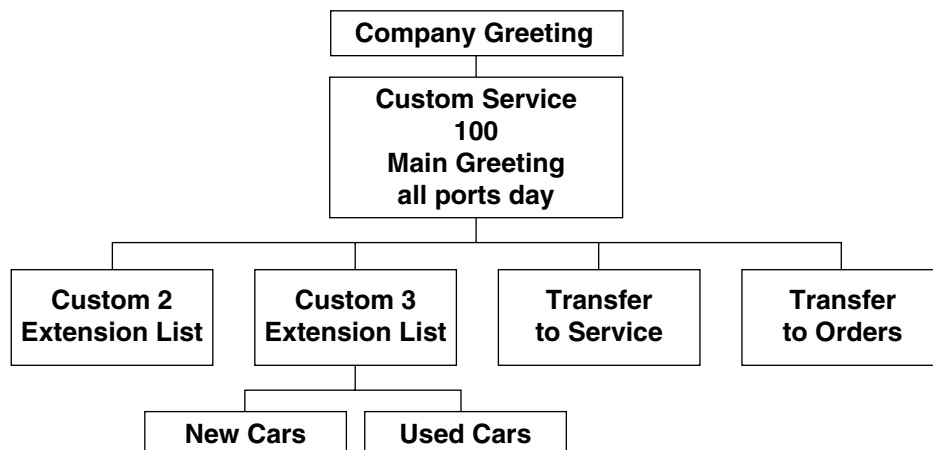

The top of the tree should include what callers will hear when they are first connected to the VPS. Then create a branch for each option until each caller option has been documented. Next, fill in each box with the action that it represents so you can easily remember what action corresponds to each keystroke.

Remember that it is possible and often necessary to have 1 custom service lead to another custom service. For example, if someone presses [1] for sales, you might want another menu to say *"for new car sales, press [1]; for used car sales, press [2]"*. This way, callers are routed directly to the person best suited to handle them.

Sample Custom Service for Foreign Languages

If you are an airline or travel agency, your callers might not be fluent in English. You can easily accommodate several languages with Custom Service. For example, each key on the keypad (there are 12 keys) could be assigned to a language. Record Custom Service Menu 100 so that the caller can select a language with one-touch dialing. For example, the top menu could be: *"For English, press 1. For French, press 2. For Spanish, press 3. For German, press 4. For Japanese, press 5. For Chinese, press 6... etc."* (of course, selections should be recorded in their respective languages).

At the next level, create menus in each language for Day Mode. For example, Custom Service Menu 2 (the one for English callers) might be: *"For departure information, press 1. For arrival information, press 2. For reservations, press 3. To leave a message, press 4. To send a fax, press 5"*. Thus at this level (or at an even lower level) a caller can be guided in his native tongue to the right person (extension), the right message-taker (mailbox), or the right device (fax machine).

In parallel, create menus in each language for Night, Lunch, and Break Modes. For example, Custom Service Menu 16 for Night Mode might be: *"Sorry, we are closed for the day. Our regular business hours are from 9 am to 5 pm, Monday through Friday. If you would like to leave a message, press 1 now. If you would like to send a fax, press 2 now"*. Record a similar message for the other languages in each mode.

5.2.2 Custom Service Features

Time Service (1-5-2-2)

Set each day of the week for the correct Day, Night, Lunch, or Break Mode.

Intercom Paging (1-5-8-7)

This feature is only available with DPT Integration.

When needed, change the paging code for each of the paging groups.

Example for KX-TD1232: All sales telephones have been placed in extension group 3 in system program [602]. No hunting type assigned in system program [106]. Assign each salesperson's mailbox to a different COS in the VPS and assign the paging group to that COS. (This tells the VPS which paging group to dial). In the Intercom paging section, assign the number "333" to the paging group assigned to the sales dept.

Fax Management (1-5-8-8)

Assigns up to 2 fax machines that can be extensions from the PBX. If the CNG tone is heard, the VPS will automatically forward the call to the first fax machine. If the first fax machine is busy or does not answer (is out of paper), the VPS forwards the call to the second fax machine. This also allows to assign an extension as the fax manager to be notified on incoming faxes.

Disconnect Parameter (1-5-8-9)

Determines how many seconds of silence the VPS allows during a caller's message before disconnecting the call.

RS-232C Settings (1-6-1)

Allows the System Administrator to change the baud rate, parity bit, etc.

Port Setting (1-6-2)

Only to be used when connecting the VPS to a PBX other than a KX-T series PBX. Use the CPC control of the PBX for normal disconnect problems.

Dialing Parameters (1-6-3-1)

These parameters are set automatically when Quick Setup is conducted.

Most of the settings will be left unchanged. The only setting that will be changed quite often is the Transfer Sequence for the operator or the extension. By default, it is set at FXA on DPT Integration and FTXA for Inband Integration. In other words, the voice processor dials the flash, waits for intercom tone and dials the extension number. By default, the VPS will stay on the line to monitor the status of the call. If the extension user answers, the voice processor will announce "*you have a call*" prior to releasing the call. This can be alleviated by adding the letter "A" or "D" to the sequence. "A" stands for answer; the call will be transferred without the announcement "*you have a call*". For a blind or unscreened transfer, add the letter "D" for disconnect.

5.2.3 Custom Service Programming

After you have finished constructing the tree, enter the *System Programming Custom Service Settings Menu*.

Access the *Custom Service Setting Menu* through the following sequence:

System Administration Top Menu:

- Enter The Number: = 1 (Program)
- Enter The Number: = 4 (Service Setting)
- Enter The Number: = 2 (Custom Service)

The system then asks what Custom Service number you want to edit. Enter the desired number (1-100).

The *Custom Service* screen is displayed:

Program - Service Setting - Custom Service Setting - Custom 1

Description ----- | A.A., Port.....
 |

Prompt Mode (1:Sys 2:User1 3:User2) ----- | System

Menu Repeat Cycle (1-3) ----- | 3 times

Call Transfer Anytime (Extn./Mbx/No) ----- | Extn.

Wait for Second Digit (1-5 s) ----- | 1 s

No DTMF Input Operation (a-f, o) ----- | c

Keypad Assignment

1:	2:
3:	4:
5:	6:
7:	8:
9:	✕: i
0: c	#:

Please choose one of the following functions or services.

a. Transfer to Mailbox	f. Custom Service	k. Dial by Name
b. Transfer to Extension	g. Voice Mail Service	l. Repeat Menu
c. Operator	h. Call Transfer Service	m. Main Menu
d. Exit	i. Subscriber Service	n. FAX Transfer
e. Previous Menu	j. Department Dialing	o. Transfer to Outside

Enter data into the Custom Service menu; use the table below as a guide.

Table 5-3

Description	Value Range (Default)	Description/Function
Description	Up to 32 characters (None)	The information typed in this field is for reference only. Any ASCII character (except \) can be used.
Prompt Mode	1. System 2. User 1 3. User 2 (System)	Specifies the language that the caller will hear when calling this Custom Service.
Menu Repeat Cycle	1-3 Times (3)	Specifies the number of times the Custom Service menu will be repeated before the No DTMF Input entry is used.
Call Transfer Any Time	Extn./Mbx/No (Extn.)	Specifies where a caller will be transferred when dialing an extension or mailbox number during the menu. If this entry is set to "Extn.", the caller will be transferred to the corresponding extension. If it is set to "Mbx", the caller will be sent directly to the corresponding mailbox. If it is set to "No", extension transfer and mailbox transfer are disabled; only 1-digit entries work (following the Custom Service menu). Note This parameter should be set to "No" when Subscriber Service is specified as a Custom Service option and it is desired that digits can be entered very quickly to specify a mailbox. Therefore, in most cases, "No" is the best setting for this parameter. This is especially true if you do not want to explain "Call Transfer Any Time" in your Custom Service menu recording.
Wait for Second Digit	1-5 s (1)	Used when the first digit of an extension is also a menu choice within the Custom Service. If a second digit is not dialed within the specified time, the menu choice is used.
No DTMF Input Operation	a-f, o (c)	Used when a caller does not dial anything when hearing the menu (usually rotary callers).
Keypad Assignment	a-0 (*=d, 0=c, others=None)	Specifies the action to be performed when a keypad digit is dialed. Callers can access specific services by pressing the appropriate keys on their telephones.

Keypad Assignment Options

Table 5-4

Entry	Function
a. Transfer to Mailbox	Allows the caller to leave messages in a specific mailbox.
b. Transfer to Extension	Transfers the caller to a specific extension.
c. Operator	Transfers the caller to the operator.
d. Exit	Plays the Custom Service exit prompt and disconnects the caller.
e. Previous Menu	Returns the caller to the previous menu.
f. Custom Service	Transfers the caller to another Custom Service and plays the menu.
g. Voice Mail Service	Allows the caller to access Voice Mail Service.
h. Call Transfer Service	Allows the caller to access Automated Attendant Service.
i. Subscriber Service	Allows the caller to access Subscriber Service. Digits received after entering this code are assumed to be the subscriber's mailbox number. If this option is enabled, it is strongly recommended that each subscriber establish a password; this will prevent unauthorized callers from accidentally or intentionally accessing subscribers' mailboxes.
j. Department Dialing	Transfer the caller to the Department Dialing menu.
k. Dial by Name	Requests the caller to enter the first 3 or 4 letters of a last name of the person they wish to reach, then transfers him to the corresponding extension.
l. Repeat Menu	Repeats the Custom Service menu prompts.
m. Main Menu	Returns the caller to the Custom Service top menu.
n. Fax Transfer	Allows the caller to send fax messages to the extension specified as the fax extension.
o. Transfer to Outside	Transfers the caller to a specific outside line.

5.2.4 Recording Menus

After you have finished entering the parameters in each menu, record the menu messages. Menu messages inform the caller of available options and their corresponding keys. For this reason, the prompts must match the programming that has been input.

Note

The Message Manager's mailbox might be 98, 998, 9998, or 99998.

1. **Dial an Extension Number** that is connected to the VPS to access the Message Manager's mailbox (9998).
2. When the VPS answers, **Press [#6×9998]** to enter the Message Manager's mailbox.
3. **Press [5]** to modify messages.
4. **Press [4]** to change the Custom Service Menu.
5. You will hear:

*Enter the Custom Service prompt number [1] through [100].
To record Custom Service Exit prompt, press [0].*

6. **Enter Custom Service Number** you want to record.
7. You will hear:

*Custom Service number (entered number).
Record menu at the tone...*

Follow the instructions until all Custom Service prompts have been recorded, using the tree that you created as a guide.

5.2.5 Checking Operation

After you have entered and recorded all menus, it is important to try the program yourself to see that all functions perform properly. Dial into the system and try all the choices to see if you are routed correctly. Verify that each menu choice works as it should.

5.2.6 Voice Mail

Voice Mail service is a message-taking service that allows non-subscribers to leave messages to subscribers. This service is often assigned when incoming calls are answered by a live person. This person can then send the caller to the Voice Mail service if desired.

Callers can access Voice Mail service by:

- **Voice Mail Port**—This service can be programmed independently of any or all ports of the VPS. Callers reaching these ports immediately access Voice Mail service.
- **Voice Mail Trunk**—This service can be programmed on a per trunk (CO line) basis. Callers reaching these trunks (CO lines) immediately access Voice Mail service.
- **Service Access Command**—A caller can switch to Voice Mail service by dialing [#6] during a call.
- **Via Custom Service**—This service can be assigned to a keypad digit within a Custom Service. After pressing this key, the caller enters Voice Mail service.

5.2.7 Mailbox Groups

This program allows a message to be delivered to several mailboxes at once. The message activates the message waiting lamps on all of the proprietary telephones. These mailboxes may be assembled into a list called a System Group Distribution List. The Message Manager can record a voice label for each System Group Distribution List (see D6 RECORDING MESSAGES). There are 20 group lists available, and each group list can have up to 20 entries.

To establish a mailbox group:

1. From the System Administration Top Menu, **Type [1-5-1-1-1]** (Program-System Parameter-System Group Assignment-Mailbox Group-Enter).
2. **Assign a List Number** to the Mailbox Group. This number can be from 2-5 digits (same as mailbox numbers). This number must be an unused number. In other words, the number assigned to this group cannot be the same as another System Group Distribution List number or mailbox number. For example, we will use the number 250.

There are 2 ways to use a System Group Distribution List:

Option A:

For inside messages: The System Group Distribution List number can be designed so that any subscriber can press [2] and then enter the list number (which is [250] in this example) to deliver a message. The message will be delivered to all specified mailboxes.

Option B:

For outside messages: The System Group Distribution List number can be designed as a custom greeting for incoming callers. For instance, the greeting might be: *"To leave a message for the parts section, press 3"*. The digit "3" would be assigned to System Group Distribution List number 250 in Custom Service Setting.

Each message waiting lamp will remain on until the message is cleared from the individual station.

5.2.8 Extension Groups

An extension group places several extensions into the same mailbox. These extensions may be assembled into a list called a Extension Group List. The extensions in the group list cannot have a personal mailbox! When a message is left in this mailbox, it lights all of the message waiting lamps of the phones that are in this group list. There are 20 group lists available, and each group list can have up to 20 entries.

When a message is left for the extension group, it will light the message waiting lamps on each phone. The first person that retrieves the call cancels the message waiting lamp on the other phones. Extension groups work well in areas where the call would not be intended for a specific person (e.g., a Parts Center, Technical Support Group, etc.).

To establish an extension group:

1. From the *System Administration Top Menu*, **Type [1-5-1-2-1]** (Program-System Parameter-System Group Assignment-Extension Group-Enter).

2. Enter an **Extension Group List Number** that has not been assigned to another mailbox or Extension Group List (this must be a vacant number). Enter the **Extensions** that are to be assigned to this group list.
3. Enter the **Extension Numbers** that are to be assigned to the Extension Group List.
4. Return to the *Main Program Menu*.
5. Type [1-1-1]
(Program-Mailbox Setting-Enter/Edit).

Assign the **Extension Group List Number** to a mailbox. If you used the number "7000" for an Extension Group List number, assign the number "7000" as a new mailbox. You must also enter 7000 as an extension.

Messages can be delivered to the new number through normal operation.

5.2.9 Interview Service

The subscriber can leave a series of prerecorded questions (up to 10) for the caller in an Interview Mailbox. As the caller answers questions, answers are recorded in the mailbox. After a caller records the answers, the interview mailbox lights a message waiting lamp. When retrieving the messages, the subscriber only hears the answers to the questions.

There are 2 ways to access an interview mailbox:

- Assign an interview mailbox to an existing mailbox
- Assign a port as an interview mailbox

To structure an interview mailbox:

1. From the *System Administration Top Menu*, Type [1-1-1 Mailbox Number-1]
(Program-Mailbox Setting-Enter/Edit-Mailbox Number-Mailbox Setting).
2. Enter the **Mailbox Number** that is to be assigned to the interview mailbox.
This should be an existing mailbox number for the person who responds to the questions.
3. At "Interview Mailbox Number" parameter, Enter a **Nonexistent Mailbox Number**. This will be the interview mailbox for this subscriber—please make a written note of it for future reference. It will not show up in Mailbox Listing. If, at a later time, you want to delete the interview mailbox, press backspace at "Interview Mailbox Number".
4. Exit System Administration Programming.
5. Enter the subscriber's mailbox and **Record** the **Questions**. Call the VPS and Press [#6*] then **Dial** the **Mailbox Number** assigned to the interview mailbox. From the *Main Menu* Press [6-1].
6. Confirm that your questions have been recorded. Call the VPS and Press [#6] and the **Interview Mailbox Number**. All your questions should be played.

Note

When using the Custom Service setting, 1 digit can be assigned to go to the mailbox of the Interview Service. The mailbox owner's message waiting lamp will go on for normal Voice Mail messages and for message left in the separate interview mailbox.

5.2.10 Automated Attendant

Automated Attendant service answers incoming calls and waits for the caller to input an extension number. It transfers the caller to the appropriate extension.

Callers can access Automated Attendant Service by:

- **Automated Attendant Port**—*This service can be programmed independently of any or all ports of the VPS. Callers reaching these ports access Automated Attendant service.*
- **Service Access Command**—*A caller can switch to Automated Attendant service by dialing [#8] during a call.*
- **Via Custom Service**—*The call transfer service can be assigned to a keypad digit within a Custom Service. After pressing this key, the caller enters Automated Attendant Service.*

Note

When the VPS calls an extension, the VPS waits for a reply. This waiting time is established by "Call Transfer No Answer Time" in Table B-32 (B6.8 Other Parameters).

5.2.11 Department Dialing Service

Callers can access extensions by pressing a key 1 through 9 (one-touch dialing). As a guide for the caller, the Message Manager should record the Department Dialing Menu—for example, "Thank you for calling. For overseas travel, press 1. For domestic travel, press 2. For group travel, press 3".

This service can be assigned to a keypad digit within Custom Service; after pressing this key, the caller will hear the Department Dialing Menu.

5.2.12 Operator Service

This service (when enabled) can be accessed via:

- **Voice Mail**—*Rotary Telephone Service allows rotary callers to reach all extensions and mailboxes.*
- **Automated Attendant**—*Dial 0 and your call will go to Operator Service.*
- **Custom Service**—*The Operator Service can be assigned to a keypad digit within a Custom Service; after pressing this key, the caller enters Operator Service. Operator Service can also be the destination of "no-DTMF-input".*

Operator Service offers callers many chances to reach a human operator. Operator Service can be structured as a cascade so that if Operator 1 cannot take the call, it goes to Operator 2. If that fails, the call goes to Operator 3. If that fails, the caller can record a message. At each stage, there are other options for busy cases and no-answer cases. Operator Service can be programmed differently for Day, Night, Lunch, or Break Mode. Each operator can be assigned a mailbox for message-taking.

5.3 SETTING PORTS

5.3.1 Port Service Menu

Access the *Port Service Menu* through the following sequence:

System Administration Top Menu:

Enter The Number: = **1** (Program)
 Enter The Number: = **3** (Port/Trunk Service)
 Enter The Number: = **1** (Port Service)

Screen output:

```
Program - Port/Trunk Service - Port Service
Enter the Port Number (1-24) :=
```

Note

The maximum number of ports depends on the VPS model.

Program - Port/Trunk Service - Port Service Menu:

1. Day Mode
2. Night Mode
3. Lunch Mode
4. Break Mode

SELECT ITEM AND PRESS KEY

Enter the data using the table below as a guide.

Table 5-5

Description	Value Range (Default)	Description/Function
Company Greeting No.	1-32 S: System Greeting N: None (None)	Specifies the company greeting to be played on the port. The System Greeting is: <i>"Good Morning/Afternoon/Evening. Welcome to the Voice Processing System"</i> .

Table 5-5

Description	Value Range (Default)	Description/Function
Incoming Call Service	1. Voice Mail 2. Auto. Attn. 3. Interview 4. Custom (Auto. Attn.)	Specifies one of 4 incoming call services. Notes <ul style="list-style-type: none"> When you specify the Interview Service, one Subscriber's Interview Mailbox number should also be specified. When you specify the Custom Service, one of 100 (1-100) Custom Service numbers should also be specified. The System Manager can change the "Incoming Call Service" remotely by simply calling the VPS (see C6 CHANGING THE COMPANY GREETING AND INCOMING CALL SERVICE SETTING).
Incoming Call Service Prompt	1. System 2. User 1 3. User 2 4. Selective (User 1)	Specifies the language of voice prompts to be played on this port. When set to "Selective", the caller can select the language of his choice, provided the Message Manager has recorded the Multilingual Selection Menu and the System Administrator has specified Prompt Selection Number. To specify Prompt Selection Number, see "System Prompt Selection Number", "User 1 Prompt Selection Number", and "User 2 Prompt Selection Number" in Table B-28 in B6.5 Prompt Setting. Note If "Selective" is specified, you will need to select a prompt available for rotary callers. See "Prompt for Rotary Callers" below.
Prompt for Rotary Callers	1. System 2. User 1 3. User 2 (System)	Specifies which language (System/User 1/User 2) a rotary caller or an External Delivery Message receiver hears when he cannot enter any digit (Prompt Selection Number) after the Multilingual Selection Menu has been played. Note "Prompt for Rotary Callers" can be assigned only when "Incoming Call Service Prompt" is set to "Selective".
Delayed Answer Time	0-60 s (0)	Specifies whether the port answers immediately (0) or in delay (1-60 s).
Time Group No.	1-8 (1)	Assigns a Time Group number to the port in Day Mode setting menu.

5.4 AUTOMATED ATTENDANT PARAMETERS

Automated Attendant parameters include: Department Dialing, Operator Parameters, and Alternate Extension.

If the VPS needs a special transfer procedure for an extension (such as modem extension), alternate extension should be assigned (see "Alternate Extension Assignment" in B5.1 Automated Attendant Parameters).

5.4.1 Automated Attendant Menu

Access the *Automated Attendant Menu* through the following sequence:

System Administration Top Menu:

Enter The Number: = **1** (Program)
 Enter The Number: = **4** (Service Setting)
 Enter The Number: = **1** (Automated Attendant)

Program - Service Setting - Auto. Attn. Setting Menu

1. Department Dialing
2. Operator's Parameters
3. Alternate Extension

5.4.2 Department Dialing

Department Dialing numbers (1-9) represent department extensions; the VPS will provide these numbers to the caller in the initial list of prompts.

Return to Program-Service Setting-Auto. Attn. Setting Menu:

Enter The Number : = 1

Program - Service Setting - Auto. Attn. Setting - Department Dialing Menu

1. Department Dialing No.1 [] := 1002
2. Department Dialing No.2 [] := 1004
3. Department Dialing No.3 [] := 1015
4. Department Dialing No.4 [] := 1036
5. Department Dialing No.5 [] := 1007
6. Department Dialing No.6 [] := 1008
7. Department Dialing No.7 [] := 1009
8. Department Dialing No.8 [] := 1010
9. Department Dialing No.9 [] := 1011

5.4.3 Operator's Parameters

If you enable operator service, you must set the following parameters: Operator's Extension and Mailbox Number, Coverage Modes, and Message Repeat Cycle.

Operator 1:

The default is set at "0" which coincides with the operator of the PBX. When a caller tries to leave a message to the Operator 1, the message will automatically go to the General Delivery Mailbox (GDM) by default.

Operators 2 and 3:

For KX-TDA/TAW series, KX-TD500, KX-TD816, KX-TD1232 and KX-TA1232, Operators 2 and 3 can be assigned to a floating number that is assigned to a ring group.

Return to Program-Service Setting-Auto. Attn. Setting Menu:

Enter The Number : = 2

Program - Service Setting - Auto. Attn. Setting - Operator's Parameters Menu

1. Day Mode
2. Night Mode
3. Lunch Mode
4. Break Mode

SELECT ITEM AND PRESS KEY

1. Operator 1
2. Operator 2
3. Operator 3

SELECT ITEM AND PRESS KEY

Enter the data using the table below as a guide. The table below is for Operator 1 as an example. Please refer to it for Operators 2 and 3.

Table 5-6

Description	Value Range (Default)	Description/Function
Operator Service	1. Disable 2. Enable (Enable)	Enables or disables the Operator Service feature. Note All non-touchtone input calls in Automated Attendant Service will be transferred to the General Delivery Mailbox when the Operator Service is disabled.

Table 5-6

Description	Value Range (Default)	Description/Function
Operator's Extension	1-5 Digits (0)	Specifies the extension number for Operator 1. Notes <ul style="list-style-type: none"> The default setting (0) cannot be used with the Message Waiting Notification—Lamp feature and the Remote Call Forwarding Set feature. When using these features, you must assign the extension number that is included in the Extension Numbering Plan. The extension number must not be assigned anywhere else (in particular, the extension must not have a mailbox). Otherwise, you will get an error message.
Operator's Mailbox No.	2-5 Digits (KX-TVS125/KX-TVS225: 998; KX-TVS325: 9998)	Callers to Operator 1 are prompted to leave a message in this mailbox depending upon how the Busy Coverage or No Answer Coverage modes are set.
Operator No Answer Time	10-60 s (30)	When a call to Operator 1, 2, or 3 is not answered within the time set, the VPS will offer other options as defined by the "No Answer Coverage Mode". Notes <ul style="list-style-type: none"> This timer applies to Operator 1, 2, and 3. If more than 1 operator is assigned, we recommend to reduce the time on the "Operator No Answer Time" to 15 s.
Busy Coverage Mode	1. Hold 2. No Answer Coverage 3. Call Waiting 4. Disconnect Message (Hold)	Specifies how to handle calls when the Operator 1 extension is busy. 1. Hold—Automatically places the caller on hold and the Operator 1 extension is called again. 2. No Answer Coverage—Offers the option specified by the No Answer Coverage Mode to the caller. 3. Call Waiting—Signals the Operator 1 when another call is waiting using the Call Waiting feature of the PBX. 4. Disconnect Message—Disconnects the caller after playing "Thank you for calling."

Table 5-6

Description	Value Range (Default)	Description/Function
No Answer Coverage Mode	1. Caller Select 2. Leave Message 3. Disconnect Message 4. Next Operator (Caller Select)	Specifies how to handle Operator 1 calls when not answered within the time period set by the "Operator No Answer Time" mode. 1. Caller Select*—Allows the caller to leave a message or call another extension. 2. Leave Message—Instructs the caller to leave a message in Operator 1's mailbox. 3. Disconnect Message—Disconnects the caller after playing "Thank you for calling." 4. Next Operator—Transfers the caller to Operator 2.
Message Repeat Cycle	1-3 Times (3)	Specifies the number of times that the VPS will play the Automated Attendant top menu.

- * *In the following cases, the caller cannot "select". He is directed to Operator 1's mailbox when he is transferred to the operator but the operator does not answer:*
- *No input to Automated Attendant.*
 - *No input to Custom Service menu when "No DTMF Input Operation" is set to "C. Operator" in Table B-16 in B5.2 Custom Service.*
 - *No input to Voice Mail service when "Rotary Telephone Call Coverage (Day/Night/Lunch/Break)" is set to "Operator Extension" in Table B-36 in B6.8 Other Parameters.*

5.5 SETTING MAILBOXES

5.5.1 Mailbox Setting Menu

Access the *Mailbox Setting Menu* through the following sequence:

System Administration Top Menu:

Enter The Number: = 1 (Program)

Enter The Number: = 1 (Mailbox Setting)

Program - Mailbox Setting Menu

1. Enter/Edit
2. Delete
3. Password Reset
4. Mailbox Listing

5.5.2 Entering a Mailbox

From Mailbox Setting Menu:

Enter The Number : = 1

Enter the Mailbox number: =

Program - Mailbox Setting - Enter/Edit Menu

1. Mailbox Setting
2. Notification Setting
3. Remote Call FWD to CO

Enter The Number : = 1

Enter the data using the following table as a guide.

Table 5-7

Description	Value Range (Default)	Description/Function
The Extension of the Owner	2-5 Digits (None)	Sets the extension to be used in conjunction with the mailbox. Any valid number can be assigned.
Owner First Name	Up to 16 alphabetic characters (None)	The Dial by Name feature uses the last name. Both will be printed on mailbox report.
Owner Last Name		
Class of Service No.	COS No.1-62 (1)	Defines a set of services available to each subscriber. The Class of Services 63 and 64 are fixed to the Message and System Managers. Most subscribers can be placed in the same COS. Anyone who needs unclaimed messages forwarded to a cell phone, beeper or another mailbox would need to be in a separate COS.

Table 5-7

Description	Value Range (Default)	Description/Function
Covering Extension	2-5 Digits (None)	Specifies where a caller will be transferred when Covering Extension is dialed or set under Incomplete Call Handling.
Interview Mailbox Number	2-5 Digits (None)	Used to permit mailbox owner to have an interview mailbox. Must be an unused mailbox.
All Calls Transfer to Mailbox	1. Yes 2. No (No)	If set to "Yes", calls coming to the extension through Automated Attendant go directly to the mailbox without ringing the extension. (Message Waiting Lamp will not be turned on.)
Caller ID Number 1 for Toll Saver	Up to 20 digits consisting of 1-9, 0, * (None)	Specifies up to two Caller ID numbers or a DID number for Toll Saver. The subscriber can check whether there are new messages in his mailbox with these phone numbers without incurring telephone charges. Note that when these phone numbers are specified by the subscriber, the phone numbers are unavailable to other subscribers in the system. (The phone numbers must be unique.) Notes <ul style="list-style-type: none"> If Toll Saver is set to "Caller ID" in your Class of Service, a DID number for Toll Saver cannot be assigned. If Toll Saver is set to "DID number" in your Class of Service, Caller ID Number 1/2 for Toll Saver cannot be assigned. If Toll Saver is set to "No" in your Class of Service, neither Caller ID Numbers nor a DID number can be assigned. DID number setting for this feature is only available when the VPS is connected to the following PBXs with DPT Integration. <ul style="list-style-type: none"> KX-TD816 (P311Q or higher) KX-TD1232 (P211Q or higher) KX-TD500 (V4M or higher)
Caller ID Number 2 for Toll Saver		
DID Number for Toll Saver		

Table 5-7

Description	Value Range (Default)	Description/Function
Extension Transfer Sequence	Up to 12 digits consisting of 1-9, 0, *, #, Y, D, F, R, T, S, W, X, A (Y:System)	<p>Specifies how the VPS transfers a call to an extension for each mailbox (Personal Transfer Sequence).</p> <p>1-9, 0, *, #: DIAL CODE</p> <p>Y: System D: Disconnect F: Flash R: Ring T: Tone S: Silence W: Transf.Wait X: Extn A: Answer</p> <p>Notes</p> <ul style="list-style-type: none"> When "System" is selected, the VPS follows the "Extension Transfer Sequence" pre-assigned for the system in the "Program - Hardware - PBX Interface - Dialing Parameters Menu". "System" cannot be used with other sequence codes. This sequence has higher priority than "Alternate Transfer Sequence".
Call Transfer No Answer Time	10-60s, S: System (System)	<p>Specifies the length of time that the VPS must wait before retrieving the transferred call when there is no answer at the destination extension. This can be set for each mailbox.</p> <p>Note</p> <p>When "System" is selected, the VPS follows the "Call Transfer No Answer Time" pre-assigned for the system in the "Program - System Parameter - Others - Dialing Parameters Menu".</p>

5.5 SETTING MAILBOXES

From Mailbox Setting Menu:

Enter The Number : = **1**

Enter the Mailbox number: =

Program - Mailbox Setting - Enter/Edit Menu

1. Mailbox Setting
2. Notification Setting
3. Remote Call FWD to CO

Enter The Number : = **2**

Program - Mailbox Setting - Enter/Edit - Notification Setting

1. 1st Device
2. 2nd Device
3. 3rd Device

Enter The Number : =

Enter the data using the following table as a guide.

Table 5-8

Parameter	Value Range (Default)	Description/Function
Dial Number	Up to 32 digits consisting of 1-9, 0, *, # P, T, M, X (None)	<p>Assigns a telephone or beeper number to Device 1, 2, or 3. The subscriber can also specify the dial number from his telephone.</p> <p>P: Pause T: Dial Tone Detection M: Dial Mode Switching Code (Touchtone to Pulse, or Pulse to Touchtone) X: Callback Number Entry Code 1-9, 0, *, #: Dial Codes</p> <p>Note</p> <p>The callback number entry code "X" must be included in the number to be called if the Beeper Callback No. Entry Mode is enabled through COS and "Type of Device" is set to "Beeper". The proper number of "Pauses" must be inserted before the callback entry code.</p> <p>Notice</p> <p>When the VPS calls to a CO line via a PRI (ISDN Primary Rate Access Interface) card of a Panasonic PBX, please be sure to add "#" after the telephone number (1112223333 in the example here): Example: 9P1112223333#PP123PP456PPX# Please contact your System Administrator for more explanation.</p>
Type of Device	1. Telephone 2. Beeper (Telephone)	Specifies the device to receive notification. This is automatically set to "Beeper" when "X" is used in the Dial Number (above). The subscriber can also specify the type of device from his telephone.
Use Mode	1. Not Use 2. Continuously 3. Scheduled (Continuously)	<p>Specifies how Device 1, 2, or 3 is to be used. The subscriber can also specify the use mode from his telephone.</p> <p>1. Not Use—Device 1, 2, or 3 is not used for a notification call. 2. Continuously—Device 1, 2, or 3 is called whenever a message is recorded in the mailbox. 3. Scheduled—Device 1, 2, or 3 is called on a schedule basis when a message has been left in the mailbox.</p>
No. of Retries	0-9 times (0)	Specifies the number of times that a notification call to Device 1, 2, or 3 should be attempted after a busy or no answer condition is received.

Table 5-8

Parameter	Value Range (Default)	Description/Function
Busy Delay Time	0-120 min (3)	Specifies the time (in minutes) the VPS must wait after a busy condition is received before making another notification call to Device 1, 2, or 3.
No Answer Delay Time	60-120 min (60)	Specifies the time (in minutes) the VPS must wait after a no-answer condition is received before making another notification call to Device 1, 2, or 3.
Time Frame 1, 2 MON: TUE: WED: THU: FRI: SAT: SUN:	1-12: h 00-59: min AM/PM: a.m./p.m. *: All Day Space: No Use (No Use)	Specifies the daily schedule for the Message Waiting Notification service for 1 week for this device. Note These parameters are active only when "Use Mode" is set to "Scheduled".

From Mailbox Setting Menu:

Enter The Number : = **1**
Enter the Mailbox number: =

Program - Mailbox Setting - Enter/Edit Menu

1. Mailbox Setting
2. Notification Setting
3. Remote Call FWD to CO

Enter The Number : = **3**

Program - Mailbox Setting - Enter/Edit - Remote Call FWD to CO

1. Telephone No.1 [] (0-9,*)
Enter the telephone No.1 : =
2. Telephone No.2 [] (0-9,*)
Enter the telephone No.2 : =

Enter the data using the following table as a guide.

Table 5-9

Parameter	Value Range (Default)	Description/Function
Telephone Number 1, 2	Up to 24 digits (With the KX-TD500) or Up to 16 digits (With other KX-T series PBXs) (None)	Specifies the telephone number to which the callers are forwarded when Remote Call Forwarding is set to a CO line. The telephone number can contain the digits "0-9" and "*". Note This feature is available with DPT Integration only.

5.5.3 Deleting a Mailbox

From Mailbox Setting Menu:

Enter The Number : = **2**

Program - Mailbox Setting - Delete
Enter the Mailbox Number : =
Are you sure? (Y/ N) : =

5.5.4 Password Reset

To reset a subscriber's password, go to the Password Reset Menu. "Enter the Mailbox Number" appears on the screen. Enter the mailbox number you wish to reset. "Enter the Mailbox Number" appears again. Enter a new number, if you wish to reset more than one password.

From Mailbox Setting Menu:

Enter The Number : = **3**

Program - Mailbox Setting - Password Reset
Enter the Mailbox Number : =
Enter the Mailbox Number : =

5.5.5 Mailbox Listing

This listing is a report of mailbox number assignments.

From Mailbox Setting Menu:

Enter The Number : = 4
Program - Mailbox Setting - Mailbox Listing

```
1: 1003  2: 1001  3: 1002  4: 1004  5: 1005
6: 1006  7: 2007  8: 1008  9: 1009 10: 1010
11: 1011 12: 1012 13: 1013 14: 1014 15: 1015
16: 1016 17: 9001 18: ---- 19: ---- 20: ----
21: ---- 22: ---- 23: ---- 24: ---- 25: ----
26: ---- 27: ---- 28: ---- 29: ---- 30: ----
      .
      .
      .
1001: ---- 1002: ---- 1003: ---- 1004: ---- 1005: ----
1006: ---- 1007: ---- 1008: ---- 1009: ---- 1010: ----
1011: ---- 1012: ---- 1013: ---- 1014: ---- 1015: ----
1016: ---- 1017: ---- 1018: ---- 1019: ---- 1020: ----
1021: ---- 1022: ----
```

System Manager's Mailbox No. :**9999**
Message Manager's Mailbox No. :**9998**

Notes

- The maximum number of mailboxes depends on the VPS model.
- Depending on the PBX extension numbering, the mailbox numbers might be 2- to 5-digit long.

5.6 TRAINING THE SUBSCRIBER

The System Administrator should explain the basic functions of the VPS to all the subscribers. He should explain which service (Voice Mail service, Automated Attendant service, Interview Service, or a Custom service) will play during the day, and what services will play during night, lunch, and breaks. He should explain that outside callers are called "non-subscribers" because they do not have mailboxes. VPS guidance prompts will assist non-subscribers in reaching the extension or mailbox they need. He should explain the responsibilities of the System Administrator, the Message Manager, and the System Manager—and how each can be contacted (phone number and/or mailbox number).

The System Administrator should also explain the special privileges of VPS subscribers. Subscribers can call from any touchtone telephone in the world and get their messages. To check messages (or change mailbox parameters) from an outside telephone, do the following:

As soon as the VPS plays a guidance message, **Press** code [# 6 *] and then **the mailbox number**. For example, a subscriber who has extension 1015 and mailbox 1015 would press code [# 6 * 1015]. If the subscriber has a password enabled, the password must be entered.

With Toll Saver enabled, the subscriber can call the VPS from anywhere in the world and find out if there are any new messages in his mailbox without incurring telephone charges.

If the subscriber forgets his password, he should contact either the System Administrator or the System Manager. Either one can clear the password so that the subscriber can establish a new password.

Explain the purpose of the General Delivery Mailbox. The Message Manager will periodically check it, and forward the contents to the appropriate subscriber.

Explain the purpose of the System Group Distribution Lists. They can be created by the System Administrator to facilitate the distribution of messages to several subscribers. In particular, senior staff members ought to know how to take advantage of System Group Distribution Lists. Twenty lists can be created, with 20 mailboxes in each list.

Finally, if Custom Service menus are used, subscribers should be encouraged to listen to these menus often and make suggestions for improvement. Custom service is a very powerful feature of the Panasonic VPS. Make the most out of this feature.

Section 6
FINAL SETUP

6.1 MESSAGE MANAGER'S MAILBOX (Mailbox 9998)

The Message Manager is responsible for recording and updating a wide variety of system messages. Please refer to D6 RECORDING MESSAGES to see the full array of recording tasks. Follow the instructions below to record Custom Service prompts and user prompts.

Note

The Message Manager's mailbox might be 98, 998, 9998, or 99998.

6.1.1 Accessing the Message Manager's Mailbox

1. **Enter an Extension Number** that is connected to Voice Mail.

You will hear the initial prompt:

Good morning/Good afternoon/Good evening.
Welcome to the Voice Processing System...

2. **Press [# 6*9 9 9 8]** to access the Message Manager's mailbox.

You will hear the following prompt if mailbox 9998 has a password set:

Enter your password, followed by a pound sign.

3. **Enter the Message Manager's Password** (if programmed). Otherwise, you will hear the *Main Menu of Message Manager's Service*.

6.1.2 Main Menu of Message Manager's Service

You have (number) new message(s).
To transfer General Delivery Mailbox messages, press [1].
To set up message waiting notification, press [2].
To customize your mailbox, press [3].
To set the clock, press [4].
To modify message, press [5].
To set station call forwarding, press [6].
To end this call, press [*].

6.1.3 Company Greetings (Enter #6*9998,5,1)

1. **Access** the *Message Manager's Main Command Menu*.
2. **Press [5]** to modify messages.
3. **Press [1]** to change the Company Greeting.
4. Continue following voice prompts through appropriate menus. Prompts lead you through the choices and recording process.

After you record the company greeting, it may be necessary to enter programming through the terminal and set the company greeting assignment under the *Port Settings Menu*, *Trunk Service Menu* and *Holiday Service Menu*. This tells the system what company greeting to play on each port and trunk (CO line) group. A company greeting should be very short.

Example: *"Thank you for calling ABC Company"*. It is not necessary to give any other instruction within the company greeting because instructions will follow the company greeting automatically. If Interview Service follows, explanations should be included in the first question (work for the subscriber who maintains the Interview Service mailbox). If Custom Service follows, explanations should be included in the first menu (work for the Message Manager).

6.1.4 Custom Service Greetings (Enter #6*9998,5,4)

1. **Access** the *Main Menu of Message Manager's Service*.
2. **Press [5]** to modify messages.
3. **Press [4]** to change the *Custom Service Menu*.
4. Continue following voice prompts through appropriate menus. Prompts lead you through the choices and recording process.

Example: *Custom Service Greeting: "Thank you for calling ABC Company. If you know your party's extension, you may dial it at any time during this message"*.

Note

This prompt should match the prompt that is selected for each port. The recording will be played directly after the call is received.

6.1.5 Customizing User Prompts (Enter #6*9998,5,6)

The customer may want to enter user prompts in place of the factory-provided system prompts. To change the user prompts:

1. **Access** the *Main Menu of Message Manager's Service*.
2. **Press [5]** to modify messages.
3. **Press [6]** to modify the User Prompts.
4. **Press [1]** to change User Prompt 1, or **Press [2]** to change User Prompt 2.
5. **Press [1]** to change specified prompts, or **Press [2]** to change all prompts.
6. **Enter the Prompt Number** you want to change.

7. Continue following voice prompts through appropriate menus.
Prompts lead you through the choices and recording process.

Note

Prompt 645: The system prompt is "This is the General Delivery Mailbox". You can record User Prompt 1 or User Prompt 2 as, "Thank you for calling ABC company. We are currently closed, however, if you leave your name and phone number, we will return your call as quickly as possible".

6.2 SETTING UP MAILBOXES

The following steps complete the basic installation of the VPS.

When you access Subscriber Service for the first time, see 6.2.1 Subscriber Tutorial.

If you want to change the current settings of mailboxes, see 6.2.2 Changing Password, Owner's Name, and Personal Greetings.

6.2.1 Subscriber Tutorial

When you access Subscriber Service for the first time, the VPS guides you to set up the mailbox with some Help messages. Simply by following the messages, you can set up these items:

- Password
- Owner's Name
- Personal Greetings (No Answer Greeting/Busy Greeting/After Hours Greeting)

This tutorial is especially helpful for subscribers to set up their mailboxes on their own.

1. **Dial** the **Extension Number** of the VPS.
2. When the VPS answers, **Press [#6*]** and **Dial** the **Number** of the mailbox which you want to personalize.
3. **Enter** your **Password** (if programmed), then **Press [#]**.

Note

A default password may be set automatically when the mailbox is created. Ask your System Administrator.

4. **Tutorial Top Menu**

The following guidance plays to explain the outline of the Subscriber Tutorial service. To listen to this guidance from the beginning, **Press [0]**.

***Welcome to the Panasonic Voice Mail System.
This is the Subscriber Tutorial service. In this service, you can set your password, record your name and record your personal greetings before you use this system. You can hear a Help message before each setup.***

5. **Setting Password**

- a) A Help message plays. To listen to the message from the beginning, **Press [0]**.
- b) The current setting plays. If you entered a password in Step 3, **go to Step 5d** below.
- c) **Enter** your **Password (up to 10 digits)**, then **Press [#]**. To skip setting the password, **Press [#]**.
- d) **Press [1]** to change the setting—**Return to Step 5c**, or **Press [2]** to accept it.

Note

We recommend you change your password frequently for good security.

6. Recording Owner's Name

- a) A Help message plays. To listen to the message from the beginning, **Press [0]**.
- b) The current setting plays.
- c) **Record the Owner's Name** at the tone.
- d) **Press [1]** to change the setting—**Return to Step 6c**, or **Press [2]** to accept it.

7. Recording Personal Greetings

- a) A Help message plays. To listen to the message from the beginning, **Press [0]**.

Note

This Help message plays only when you access the No Answer Greeting setting for the first time.

This does not play in the Busy Greeting or After Hours Greeting setting.

- b) The current setting plays.
- c) **Record No Answer (Busy/After hours) Greeting** at the tone.

Example: "Hi this is Tom. I am away from my desk right now but please leave a message at the tone and I will return your call as soon as possible".

Note

The VPS will guide you to record No Answer Greeting, Busy Greeting and After Hours Greeting in this order.

- d) **Press [1], [2], [3], [4], or [5]** to choose the desired entry.

- [1] To review
- [2] To accept
- [3] To erase and try again
- [4] To add
- [5] To erase and exit

8. Tutorial Confirmation Menu

- a) **Press [1], [2], or [*]** to choose the desired entry.
 - [1] To confirm your settings
 - [2] To enter Subscriber Service
 - [*] To end the call

Note

To end the call while in Steps 4-8, press [*].

6.2.2 Changing Password, Owner's Name, and Personal Greetings

1. **Dial** the **Extension Number** of the VPS.
2. When the VPS answers, **Press [#6*]** and **Dial** the **Number** of the mailbox whose Password/Owner's Name/Personal Greetings you want to change.
3. **Enter** your **Password** (if programmed), then **Press [#]**.
You are now inside the mailbox.
4. **Press [5]** for Mailbox Management.
5. **Press [1], [2], or [3]** to choose the desired entry, and change the setting according to the guidance you hear.
 - *[1] To change the Personal Greetings*
 - *[2] To change the Password*
 - *[3] To change the Owner's Name*

TEST THE SYSTEM

Before backing up the system, call each extension to see that each port functions as it should. Check for proper greetings and call transfers.

6.3 BACKING UP THE SYSTEM

1. Choose the **Utility Command**. Type [**SAVE**], then Press **ENTER**. See screen output below.

From System Administration Top Menu:

Enter The Number : = 3
Utility Command

```

$ SAVE
VPS DISK Data Save ( VPS -> PC : Xmodem )
1: Program
2: Parameters
3: System Prompts
4: User Prompts-1
5: User Prompts-2
6: Custom Service Menus
7: Personal Greetings
8: Company Greetings
Select No. : = 2

```

2. To start, Press [**2**] and then **ENTER**.
3. Press **RETURN** or **ENTER**.

Following steps are for HyperTerminal as an example.

4. Select Recieve File from the Transfer Menu.
5. Specify a **folder** where data is to be saved (if necessary, use "Browse").
6. Select *Xmodem* as the protocol to save data.
7. Click "Recieve".
8. Enter desired **filename** and click "OK".

The file transfer screen appears and shows download progress. Download time will vary depending on the communication speed and file sizes.

"SAVE Completed" will appear on the screen when the file has been saved. Continue saving the other items as needed. It is not necessary to save the "Program" or "System Prompts" because they are resident on the hard drive and cannot be altered. We do recommend all other data be saved including User Prompt 1 and User Prompt 2 (if they have been recorded).

Notes

Recorded caller names for the Caller Name Announcement (System/Personal) cannot be saved by the above procedure, only Caller ID numbers can be saved. When the saved

Caller ID numbers are loaded using LOAD command, the following things should be done:

- For System Caller Name Announcement, the Message Manager rerecords caller names (see "Recording System Caller Names" in D6 RECORDING MESSAGES).
- For Personal Caller Name Announcement, subscribers rerecord caller names (see 4.12 Personal Caller Name Announcement in the Subscriber's Guide).

User Prompt files are very large and can take several hours to save. Store saved files in a safe area.

Section 7

**SYSTEM MAINTENANCE AND
TROUBLESHOOTING**

7.1 INITIALIZING THE SYSTEM

Initializing the system clears all voice data except user prompts and returns all system parameters to their default settings. Throughout this section, menu selections are indicated as "**System Administration Top Menu-(Selection Number)**". This means that the System Administration Top Menu must first be accessed. On the first menu displayed, make the menu selection corresponding to the first menu displayed. Repeat this process for each subsequent menu when additional selection numbers are listed.

To initialize the system, follow the menu path as shown:

System Administration Top Menu-4

Note

In the following steps (steps 1 through 6), the output of the VT100 TERMINAL mode is presented. The output of the ASCII TERMINAL mode is slightly different. For example, in Step 1, "5: Quick Setup" does not appear when you are in the ASCII TERMINAL mode. There are other differences, but the basic steps are the same.

1. Go to the System Administration Top Menu

```
1 : Program
2 : System Reports
3 : Utility command
4 : System Reset/Clear
5 : Quick Setup

SELECT ITEM and PRESS Return-Key
```

2. Type [4] for System Initialization.

```
System Reset/Clear Menu
Mailbox No. Length :4
System Manager's Mailbox No. :9999
Message Manager's Mailbox No. :9998

Will you change the settings ? (Y/N): =
```

Note

Depending on the PBX extension numbering, the "Mailbox No. Length" might be 2 to 5.

3. Type [Y] (this places the VPS in the off-line mode).

```

System Reset/Clear Menu
Mailbox No. Length :4
System Manager's Mailbox No. :9999
Message Manager's Mailbox No. :9998

Reset System Parameters : Press \

```

4. Type [N].

```

*****
* Caution!!! *
* Now, System Initialization Starts. *
*****
Is it all right ? (Y/N):=

```

5. Type [Y] to start the system resetting.

```

System Initializing
Wait a moment...
.
.
.

```

6. When system initializing is complete, the following display will appear:

```

>

```

(KX-TVS325 only.) When activating the Quick Setup remotely through the internal modem, the line will be disconnected because the VPS will automatically restart upon finishing the Quick Setup. Please re-establish remote access to the VPS via the internal modem.

Note

The execution time for System Reset/Clear may differ each time it is performed because of system capacity and system programs.
Generally, initialization will take about 10 min to accomplish.

7.2 UTILITY COMMANDS

In the Utility Command Mode, the System Administrator can access the functions described below by entering the appropriate command at the "\$" prompt, and **Pressing RETURN**.

To select the Utility Commands Menu, follow the menu path as shown:

System Administration Top Menu-3

Utility Command (Type 'HELP' for command list.)
\$

Table 7-1

OFLN:	Sets the system to off-line mode
ONLN:	Sets the system to on-line mode
PASS:	Sets the System Administrator's password
TIME:	Sets the system clock, date, and time
PSET:	Specifies the reports printing time
ELOG:	Displays device error log
SAVE:	Stores a backup of the program or data in the hard disk
LOAD:	Restores a backup of the program or data to the VPS
GPRN:	Displays all of the VPS parameters
VERS:	Displays the version of the program
CREP:	Displays the keypad assignments, message recording status and the tree-structure of a Custom service
CCLR:	Clears a Custom service menu access count
MWL:	Specifies the number of times the VPS attempts to turn on the message waiting lamp on the extensions
MRL:	Sets the minimum recording length of a message
MPLT:	Displays the user prompt recording status
HELP:	Displays brief instructions and a list of Utility Commands
QSET:	Set up your VPS roughly so that you can use it quickly
LMON:	Line Monitor
PUTD:	Displays Touchtone Information
WCID:	Wait for Caller ID
TURN:	Turn off System/User Prompt
PREP:	Personal Custom Service Assignment

7.2.1 Off-line Set (OFLN)

Use the OFLN command to turn off the VPS Call Progression Mode. Set the VPS to Off-Line Mode before deleting a mailbox, since this operation involves the updating of a large number of related parameters.

Type OFLN, then **Press RETURN**. If no VPS ports are in use, the VPS will immediately suspend the Call Progression Mode.

```
$ OFLN
** OFF LINE MODE **
```

If any VPS port is in use, the VPS will display the following warning:

```
*** Now line is used!! *** <WAIT>
```

The following message indicates that the VPS is in the Off-Line Mode.

```
** OFF LINE MODE **
```

7.2.2 On-line Set (ONLN)

Use the ONLN command to place the VPS in the Call Progression Mode.

Type ONLN, then **Press RETURN**.

```
$ ONLN
** ON LINE MODE **
```

7.2.3 Set Password (PASS)

Use the PASS command to create, change and clear system passwords. Valid passwords are created using up to 10 characters; any alphanumeric character, [(space)], [.] and [_] can be used.

IMPORTANT

- *We strongly recommend that you set the password to 10 characters for maximum protection against hackers.*
- *Do not carelessly reveal the password to other persons.*
- *Please change the password periodically.*

1. Type PASS, then **Press RETURN**.

```
$ PASS
1: Administrator Password 2: System Reset/Clear Password :=
```

2. To create a password or change an existing password, **Go to Step 3**.
To clear a password, **Go to Step 4**.

- To create a password or change an existing password:

- Type [1] or [2]

```
Maximum 10 characters  
NEW PASSWORD : =
```

Note

When you press [2] to change the System Reset/Clear password, you should type the current (OLD) password before entering a new one.

- Type the password.

```
VERIFICATION: =
```

- Type the password again for verification.

- To clear a password:

- Type [1] or [2].

```
Maximum 10 characters  
NEW PASSWORD : =
```

- Press ENTER. Do not type a password on this screen.

```
VERIFICATION : =
```

- Press ENTER. Do not type a password on this screen.

Note

The password entered on the screen will not appear. The VPS does not distinguish the capital letter from the small letter.

7.2.4 Set Time (TIME)

Use the TIME command to set the system date and time. A number of system functions require that the system time and date be set correctly. These functions include message waiting notification, external message delivery, call-retries-after initial-failure-to-connect, and automatic deletion of messages.

Time Synchronization: If you have DPT Integration between the VPS and your PBX (latest software version), the date and time are automatically sent from the PBX to the VPS whenever the PBX sets the date and time. Also, this transfer occurs whenever DPT Integration is established.

- Type TIME, then Press RETURN.

```
$ TIME  
Current time is 12:34, PM  
Enter new time (HH:MM, AM/PM) : =
```

- Type the current time.

```
Current date is MON JAN-1-2001  
Enter new date (MM-DD-YY) : =
```

3. **Type** the current date. For the year, type the last 2 digits.

Note

Enter the exact time and date. This command cannot be used when either the System or the Message Manager is accessing the time setting feature.

7.2.5 Print Reports at Specified Time (PSET)

Use the PSET command to issue system usage reports (Disk Usage Report, Port Usage Report, Call Account Report) at a specified time each day. A printer or data terminal must be connected to the VPS at the RS-232C port for the reports to be printed or displayed.

1. **Type PSET**, then **Press RETURN**.

```
$ PSET
Report Print Out Service [ Disable ]
  1 : Enable  2: Disable :=
```

2. **Type [1]** to enable this function or **Type [2]** to disable it.

```
Enter The Print Out Time (HH:MM, AM/PM) :=
```

3. **Type** the time to print the reports.

Note

The reports will be displayed only if the system is in the mode where you see the following prompt:

```
>
```

7.2.6 Error Log Display (ELOG)

Use the ELOG command to diagnose VPS problems. Selection of this command will display an error log.

COM. Communication error between CPU and DSP
 DATA Process error of voice data
 MEM. Memory error
 PRG. Program error in CPU card
 R/W Read/Write error of Hard Disk

Type **ELOG**, then Press **RETURN**.

\$ ELOG	DEVICE	ERROR	TIME
1.	CPU	MEM-GET	JUL-14 2:00 PM
2.	CLOCK		JUL-14 2:00 PM
3.	DISK	DATA R/W (xx:yyyy)	JUL-14 2:00 PM
4.	DSP*	SCAN	JUL-14 2:00 PM
5.	DSP*	FIFO	JUL-14 2:00 PM
6.	CPU	APPLICATION (x)	JUL-14 2:00 PM

* = Port number (KX-TVS125: 1-6; KX-TVS225: 1-12; KX-TVS325: 1-24)

Note

The following tables display and explain the errors that the system can identify.

Table 7-2 Device Error Log Indications

Indication		Meaning
CPU	MEM-GET	CPU board software memory acquisition error. CPU board is short of memory temporarily because of too much traffic.
CLOCK		Clock access error. Clock IC is out of order. Check the hardware.
DISK	DATA R/W (xx:yyyy)	HDD access error. If there is a sector that often causes errors, check the disk. xx : IDE error code yyyy : read/write error sector number
DSP*	SCAN	DSP-SCAN error. DSP is out of order. Check the hardware.
DSP*	FIFO	DSP/FIFO error. During the system is handling calls, there is something wrong with DSP and FIFO memory temporarily.
CPU	APPLICATION (x)	Application error. While the system is handling calls, temporary application error occurs. x: port number

* = Port number (KX-TVS125: 1-6; KX-TVS225: 1-12; KX-TVS325: 1-24)

Examples of a terminal display when errors are generated:

Table 7-3 Error Indications at System Startup

Indication	Meaning
ROM ERROR: Sum Error!!	ROM checksum error.
DISK ERROR: Initialize Error!!	HDD initialization error.
DISK ERROR: No System!!	No system HDD present.
DISK ERROR: Program Load Error!!	Program could not be loaded from system HDD.
DISK ERROR: Program Sum Error!!	Checksum error in program loaded from system HDD.
DISK ERROR: System Data Error!!	Error Loading of administrator data from system HDD.
SYSTEM ERROR: 1	Administrator data error.
SYSTEM ERROR: 2	Error loading of report data.
SYSTEM ERROR: 3	Clock error.
SYSTEM ERROR: 4	Mailbox data error.
SYSTEM ERROR: 5	Message data error (1).
SYSTEM ERROR: 6	Message data error (2).
SYSTEM ERROR: 7	Error loading of control data.
SYSTEM ERROR: 8	Error loading of voice prompt data.
SYSTEM ERROR: 9	Error loading of MWL control data.
SYSTEM ERROR: 10	Error loading of disk identify data.
SYSTEM ERROR: 11	Error writing of VBI chain data.
SYSTEM ERROR: 12	Error writing of BLK chain data.
SYSTEM ERROR: 13	Error loading of user prompt modify data.
SYSTEM ERROR: 14	Error loading of Class of Service data.
No CO lines are active!!	No Port cards present.
COs are all disabled!!	All Ports are malfunctioning.
DPT Interface Connection is not Established.	Ports are malfunctioning for DPT Integration because telephone lines are disconnected or Integration with PBX is not set to DPT integration mode.

Table 7-4 Error and Warning Indications During System Operation

Indication	Meaning
DISK STORAGE SPACE IS NOW EXCEEDING 80%...	80 % or more of the HDD voice message save area is used.
ASCII TERMINAL program Load Error	Error loading of ASCII terminal control program.
VT100 program Load Error	Error loading of VT100 control program.

7.2.7 Saving the System Data to the Backup Device (SAVE)

All system programming data and voice prompts (8 functional areas) can be saved in separate data files. To save this data, connect a data terminal to the RS-232C port of the VPS. Save the files individually. Execute the SAVE command for each data file. It will require several minutes to execute this command for all the data selected. When performing this operation, always wait until the process completion indication appears.

WARNING

Never save (back-up) and upload the "Program" without Panasonic Technical support.

The memory required to save each data component is indicated below.

1. Program—approximately 2 Mbytes (See Warning above)
2. Parameters—approximately 4.4 Mbyte (System Configuration)
3. System Prompts—approximately 23 Mbytes (Do not save—prompts are saved as defaults in the drive)

Saving items 4-8 below will depend upon the length of the recorded messages.

4. User Prompts-1
5. User Prompts-2
6. Custom Service Menus (Custom service recordings)
7. Personal Greetings (Subscriber greetings)
8. Company Greetings

1. Type SAVE, then Press RETURN.

```

$ SAVE
VPS Disk Data Save (VPS -> PC : Xmodem)
1: Program
2: Parameters
3: System Prompts
4. User Prompts-1
5. User Prompts-2
6. Custom Service Menus
7. Personal Greetings
8. Company Greetings
Selection No. :=

```

2. Select item to be backed up, then Press RETURN. The size of the file will be displayed.

```

To start press 'RETURN'

```

3. Press RETURN.

```

----- SAVE Start!!

```

4. Perform a Standard File Transfer. Set the data terminal to the receiving (Answer) mode (Xmodem) and specify the backup filename. The specified data will be transmitted to the data terminal.**Notes**

- The data terminal that you use must be equipped with communications software that supports the Xmodem file transfer protocol. The command can be canceled by Typing [^] before entering the receiving mode. Once the receiving mode has been selected, use the cancel command of the communication software being used.
- If your data terminal supports a high speed, it is recommended that you SAVE at the maximum speed of 38400 bps. First, change the RS-232C setting of the VPS (see B7.1 RS-232C Parameters). Next, change the RS-232C setting of your data terminal to the same speed.

7.2.8 Loading New or Saved Data to the VPS (LOAD)

Use the LOAD command to install new data or to restore saved data to the VPS. Execute this command for each data file.

When performing this operation, always wait until the process completion indication appears before proceeding.

1. Type **LOAD**, then **Press RETURN**.

```
$ LOAD
VPS Disk Data Load (PC -> VPS : Xmodem)
1: Program
2: Parameters
3: System Prompts
4: User Prompts-1
5: User Prompts-2
6: Custom Service Menus
7: Personal Greetings
8: Company Greetings
Selection No.: =
```

2. Select the item to be restored to the hard disk, then **Press RETURN**.

```
To start press 'RETURN'
```

3. **Press RETURN**.

```
----- Load Start!!
```

When "CCC" appears, the VPS is ready for loading.

4. Set the data terminal to the sending (Call) mode (Xmodem). Then enter the backup filename. **Press ENTER**. The backup data will be restored to the hard disk.

5. When the load to the VPS has been completed, power-off and restart the VPS.

Notes

- The data terminal that you use must be equipped with communications software that supports the Xmodem file transfer protocol. The command can be canceled by Typing [^] before entering the sending mode. Once the sending mode has been selected, use the cancel command of the communication software being used.
- If your data terminal supports a high speed, it is recommended that you LOAD at the maximum speed of 38400 bps. First, change the RS-232C setting of the VPS (see B7.1 RS-232C Parameters). Next, change the RS-232C setting of your data terminal to the same speed.

7.2.9 Print All of the VPS Parameters (GPRN)

Use the GPRN command to print all VPS parameter settings (output to screen). Use Ctrl-C at any time to stop printing.

Type **GPRN**, then Press **RETURN**.

```
$ GPRN
  0: All Parameters
  1: Mailbox Setting
  2: Class of Service Setting
  3: Port/Trunk Service Setting
  4: Service Setting - Auto. Attn. Setting
  5: Service Setting - Custom Service Setting
  6: Service Setting - Intelligent Call Handling
  7: Service Setting - Toll Saver Setting
  8: System Parameter Setting - System Group Assignment
  9: System Parameter Setting - Time Group Service, Holiday, Daylight Saving Time
 10: System Parameter Setting - Prompt Setting
 11: System Parameter Setting - System Caller Name Announcement, System Security
 12: System Parameter Setting - Others
 13: Hardware Setting
 14: System Reset Clear Parameter

Please select : =
```

Note

This command is only valid when in the ASCII TERMINAL mode.

7.2.10 Program Version Display (VERS)

Use the VERS command to display the version numbers of the hard disk and main ROM.

Type **VERS**, then Press **RETURN**.

```
$ VERS
V.P.S. PROGRAM VERSION

MAIN DISK : VU21AA (4.52)
MAIN ROM  : VU01AA (1.03)
```

Note

The numbers are examples only. Your system will show different numbers.

7.2.11 Custom Service Report (CREP)

Use the CREP command to display the Custom Service menu access count, the keypad assignments, message recording status and the tree-structure of the Custom Service.

Type CREP, Press Space, Enter the Custom Service number (1-100), and Press RETURN.

```

Custom [100] (System) (Access: 9) (Menu Msg. : None)
  | < multilingual pick >
  [N]- Xfer Mbx (9998)
  [0]- Operator
  [1]- Custom [1] (System) (Access: 2) (Menu Msg. : None)
    | | <English service>
    | | [N]- Operator
    | | [0]- Operator
    | | [1]- A.A. Service
    | | [2]- V.M.Service
    | | [3]- FAX Transfer
    | | [*]- Subscriber
  [2]- Custom [2] (User -1) (Access: 2) (Menu Msg. : None)
    | | <French service>
    | | [N]- Operator
    | | [0]- Operator
    | | [1]- A.A. Service
    | | [2]- V.M.Service
    | | [3]- FAX Transfer
    | | [*]- Subscriber
  [3]- Custom [3] (User -2) (Access: 3) (Menu Msg. : None)
    | | < Vietnamese service>
    | | [N]- Operator
    | | [0]- Operator
    | | [1]- A.A. Service
    | | [2]- V.M.Service
    | | [3]- FAX Transfer
    | | [*]- Exit
  [4]- Dept Dial
  [5]- Repeat Menu
  [*]- Exit
  [#]- Main Menu

```

Custom [100]:	Indicates that Custom Service No. is "100".
System:	Indicates that "System" prompts are active.
Access: 9:	Indicates that the callers have accessed this Custom Service 9 times. This counter can be cleared. See 7.2.12 Custom Service Menu Access Count Clear (CCLR).
Menu Msg. :None:	Indicates that the menu message for this Custom Service is "None (not recorded)". If menu message is recorded, "Rec" will appear.
[N]-Xfer Mbx (9998):	Caller will be sent to General Delivery Mailbox (GDM) if he dials nothing.
[1]-Custom [1]:	Custom Service 1 will play when the "1" key is pressed.
[2]-Custom [2]:	Custom Service 2 will play when the "2" key is pressed.
[3]-Custom [3]:	Custom Service 3 will play when the "3" key is pressed.
[4]-Dept Dial:	Department Dialing menu will play when the "4" is pressed.

7.2.12 Custom Service Menu Access Count Clear (CCLR)

Each Custom Service has an access counter that counts the number of times the service has been accessed. This command clears this counter.

Type **CCLR**, Press **Space**, and **Enter** Custom Service Menu (1-100), then Press **RETURN**.

```
$ CCLR 20
    Custom Menu <20> Access Counter Cleared !!
```

Note

Type CCLR 0 to clear the access counters of all Custom Services.

7.2.13 Message Waiting Lamp Retry Times (MWL)

Use the MWL command to specify the number of times the VPS will attempt to turn on the Message Waiting Lamp of the called extension. Apply this setting when a PBX other than the Panasonic KX-T series telephone system is used.

```
$ MWL
    Current Setting of M.W.L. Retry Count is 3
    Enter M.W.L. Retry Count (1-3) =
```

Note

This setting is not valid if "Message Waiting Lamp for Every Message" is set to "Yes".

7.2.14 Setting Minimum Recording Length (MRL)

Use the MRL command to specify the minimum message recording length (0-3 s). Messages shorter than the specified minimum recording length are discarded from the mailbox.

Note

The minimum recording length can only be set using this command.

1. Type **MRL**, then Press **RETURN**.

```
$ MRL
    Current Setting of Minimum Recording Length is 2
    Enter Minimum Recording Length (0-3) =
```

2. Type the message length.

7.2.15 Modified Prompt List (MPLT)

Use the MPLT command to display the user prompt recording status: recorded, not recorded, or turned off.

Type **MPLT**, then **Press RETURN**.

MPLT → both prompts

MPLT 1 → User 1 prompts

MPLT 2 → User 2 prompts

```

$ MPLT 1

***List of Registered User Prompt 1 No. ([1], [2], . . . , [1010])***
, 1, , OFF, , 5*, 6, , , , , , , , , , ,
, , , , , , , , , , , , , , , ,
, , , , , , , , , , , , , , , ,
, , , , , , , , , , , , , , , ,

,
,
,

, , , , , , , , , , , , , , , ,
, , , , , , , , , , , , , , , ,
, , , , , , , , , , , , , , , ,

*** Total number of Registered = 3 ***
*** Total number of TURNED OFF = 2 ***
  
```

- Blank: The prompt has not been recorded (but the default [System Prompt] is active)—WILL BE HEARD
- Prompt No.: The prompt has been recorded—WILL BE HEARD
- Prompt No. with an*: The prompt has been recorded but is turned off—WILL NOT BE HEARD
- "OFF": The prompt has never been recorded and the default prompt has been turned off—WILL NOT BE HEARD

Note

The "Total Number of Registered" shown at the bottom of the screen does not include the prompts that have been turned off.

7.2.16 Utility Command List (HELP)

Use the HELP command to display the list of all available utility commands.

Type **HELP**, then Press **RETURN**.

```

$ HELP
OFLN      : System Off-line
ONLN      : System On-line
PASS      : Password setting
TIME      : Time & Date setting
PSET      : Report Print Out Time setting
ELOG      : Device Error Log Listing
SAVE      : VPS Program & Date Save (VPS → PC : Xmodem)
LOAD      : VPS Program & Date Load (VPS ← PC : Xmodem)
GPRN      : Parameter Global Printing (only 'ASCII Terminal' mode)
VERS      : Program Version Check
CREP [no.] : Custom Menu Information List
            [no] : Custom Menu No. (1-100)
CCLR [no.] : Custom Menu Access Counter Clear
            [no] : Custom Menu No. (1-100/0) (0: Clear All)
MWL       : MWL Retry count Set (1-3)
MRL       : Minimum Recording Length Set (0-3)
MPLT [opt] : Registered User Prompt No. List
            [opt] : 1 → User Prompt 1
                   2 → User Prompt 2
                   None → User Prompt 1&2
QSET      : Quick Setup
LMON      : Line Monitor
PUTD      : DTMF Information Display (Don't leave enabled after
            troubleshooting.)
WCID      : Wait Time for Caller ID
TURN      : Turn off System/User Prompt
PREP      : Personal Custom Service Assignment
$

```

7.2.17 Quick Setup (QSET)

Use the QSET command initially to setup the VPS very roughly when you use it for the first time or after system initialization.

Note

Quick setup requires VT100 emulation software.

Type **QSET**, then Press **RETURN**.

7.2.18 Circuit Condition Display (LMON)

Use the LMON command to display the circuit condition every 1.5 s. To turn off this command, enter [N].

The following circuit conditions may be displayed.

"Ready"	: Possible to serve
"Incoming Call"	: Processing arrival service
"Outgoing Call"	: Processing sending service
"DSP Reset"	: Processing DSP reset disposition
"PT connect"	: Processing PT connect disposition
"Error"	: DSP Card is not loaded

```

$ LMON
  No.:  Status          No.:  Status
    1:  Ready          13:  Error
    2:  Ready          14:  Error
    3:  Ready          15:  Error
    4:  Ready          16:  Error
    5:  Ready          17:  Error
    6:  Ready          18:  Error
    7:  Ready          19:  Error
    8:  Ready          20:  Error
    9:  Ready          21:  Error
   10:  Ready          22:  Error
   11:  Ready          23:  Error
   12:  Ready          24:  Error
    
```

Note

The maximum number of ports depends on the VPS model.

7.2.19 Touchtone Information Display (PUTD)

Use the PUTD command to display the touchtones the VPS receives and sends.

In addition to the touchtones, the following will be displayed—the Incoming Call Service (Voice Mail, Automated Attendant, Custom, and Interview) entered by the caller and the time periods that the ports are enabled.

Type PUTD. The VPS will remain in this mode until "PUTD" is entered again. The default setting of this mode for all ports is "OFF".

```

$ PUTD
  Target Port : **** *
  Don't leave enabled after troubleshooting.
$
    
```

To change the mode from "PUTD" to "OFF", **Type PUTD** again.

```

$ PUTD
  Target Port : 0000 0000 0000 0000 0000 0000
  Don't leave enabled after troubleshooting.
$

```

Note

"*" means "enable" for the port. "0" means "disable" for the port.

To set the mode for only 1 port, **Type PUTD** and the port number.

```

$ PUTD 1
  Target Port : 0000 0000 0000 0000 0000 000*
  Don't leave enabled after troubleshooting.
$

```

Sample display:

```

$ PUTD
  Target Port for Debug : * * * * *
  Don't leave enabled after troubleshooting.
$
[1] DTMF:3
[1] DTMF:8
[1] A.Attend
[1] DTMF:#
[1] DTMF:6
[1] Voice Mail
[1] DTMF:1
[1] DTMF:0
[1] DTMF:1
[1] NonSub Svc
[1] * * *
[1] DTMF:#
[1] DTMF:9
[1] Thank you

```

Note

The maximum number of ports depends on the VPS model.

WARNING

"PUTD" is a command originally used when troubleshooting. Do not use this command for any other purpose. Do not disconnect the RS-232C connection while the "PUTD" command is enabled. This could cause data overflow.

7.2.20 Wait for Caller ID (WCID)

Use the WCID command to specify the length of time (in seconds) the VPS must wait for the Caller ID after the VPS has received the incoming call from the PBX.

If Caller ID is not needed at all, set the waiting time to "0" to accelerate the VPS response to incoming calls.

Type **WCID**, then Press **RETURN**.

```
$ WCID
  WAIT TIME FOR CALLER ID (5 sec) [0-60 sec] : = 0
$
```

7.2.21 Turn off System/User Prompt (TURN)

Use the TURN command to turn off specific System/User prompts, or to display the numbers of the currently turned-off prompts.

Type **TURN**, Press **Space**, Enter the **prompt type** (0: System Prompts, 1: User 1 Prompts, 2: User 2 Prompts), Type a **comma**, and Enter the **prompt number** you want to turn off. Then Press **RETURN**.

Sample display:

```
$ TURN 0,100
System Prompt No.100 has been changed from 'Turn ON' to 'Turn OFF'
*****
* Turned off Prompt No. *
*****
System Prompt
  100
User1 Prompt
  None
User2 Prompt
  None
$
```

Note

You can turn on the prompts which have been previously turned off using the procedure above.

Type **TURN**, then Press **RETURN**. The numbers of the currently turned-off prompts will be displayed.

Sample display:

```

$ TURN
*****
* Turned off Prompt No. *
*****
System Prompt
  100

User1 Prompt
  200, 300, 952

User2 Prompt
  123, 345, 700, 900,1000
$

```

7.2.22 Personal Custom Service Assignment (PREP)

Use the PREP command to display the Personal Custom Service Assignment.

Type **PREP** and the **mailbox number**, then Press **RETURN**.

```

$ PREP 101
** Personal Custom Service Assignment   JUL- 1-2003  7:24 PM  **
MBOX: 101 [ ICHIRO SUZUKI ]

[3]-Xfer Mbx(9998)
[4]-Xfer Extn.(1006)
[5]-Xfer CO(2011234567)
[6]-Custom[ 56]
[7]-V.M. Service
[8]-A.A. Service
[N]-Message Recording

```

Note

"*" can be used as a wild card within the mailbox number. The Personal Custom Service Assignments of all matching mailboxes are displayed.

7.3 SYSTEM REPORTS

The System Administrator is able to generate 8 System Reports to monitor VPS operating status. The reports can be displayed on a data terminal or printed. The terminal or printer must be connected to the RS-232C port. (The System Manager is also able to output System Reports.)

To select the System Reports Menu, follow the menu path as shown:

System Administration Top Menu-2-1

System Reports – System Report Menu

1. Mailbox Assignments
2. COS Assignments
3. System Service Report
4. Call Account Report
5. Port Usage Report
6. Disk Usage Report
7. Mailbox Usage Report
8. Fax Call Report

Enter the Number : =

The following 4 reports can be cleared of all values and prepared for use again.

To clear the following 4 reports, follow the menu path as shown:

System Administration Top Menu-2-2

System Reports – System Clear Menu

1. Call Account Report Clear
2. Port Usage Statistics Clear
3. Disk Usage Statistics Clear
4. Mailbox Usage Statistics Clear
5. Fax Call Report Clear

Enter the Number : =

7.3.1 Mailbox Assignments

The Mailbox Assignments report provides information about the applied mailbox authorized features and current parameter settings.

Note

Depending on the PBX extension numbering, the mailbox numbers might be 2- to 5-digit long.

To select the Mailbox Assignments Report, follow the menu path as shown:

System Administration Top Menu-2-1-1

**Mailbox Assignments													NOV-2-2002 4:54 PM **	
MBOX	Extn.	Name (Fir/Lst)	COS	CExtn	IVMBOX	AITrf	NT	TS	NA	MN1st	MN2nd	MN3rd	RF	PC
1001*	1001	JONE / DELY	1	1002	7001	X	A	S	S	Tel	Bep	Tel	A	A
1002	1002	CLUS / ALCC	1	-	-	-	-	U	60	---	---	---	-	-

9998	-	- / -	63	-	-	-	-	-	-	---	---	---	-	-
9999*	-	- / -	64	-	-	-	-	-	-	---	---	---	-	-

- | | | | |
|---------|--|--------|-------------------------------|
| COS: | Class of Service | CExtn: | Covering Extension |
| IVMBOX: | Interview Mailbox | AITrf: | All Call Transfer to Mailbox |
| NT: | Number for Toll Saver | TS: | Extension Transfer Sequence |
| NA: | Call Transfer No Answer Time | MN1st: | Message Notification Device 1 |
| MN2nd: | Message Notification Device 2 | MN3rd: | Message Notification Device 3 |
| RF: | Remote Call Forward to CO | PC: | Personal Custom Service |
| X: | The feature marked with X is set to "YES". | A: | Something is assigned. |
| S: | System | Bep: | Beeper |
| Tel: | Telephone | | |

Note

Mailboxes with a password set are indicated with a "X" after the mailbox number.

7.3.2 COS (Class of Service) Assignments

The COS (Class of Service) Assignments report provides information concerning all Class of Service numbers.

For a complete explanation of COS parameters, please see Table B-7 and Table B-8 in B3 SYSTEM ADMINISTRATION—SETTING COS (CLASS OF SERVICE) PARAMETERS.

To select the COS Assignments Report, follow the menu path as shown:

System Administration Top Menu-2-1-2

7.3 SYSTEM REPORTS

** COS Assignments																									SEP-20-2003		5:39 PM		**		
COS	RtN	RtS	Ln	CaN	CaT	RO	SI	Pr	DC	EV	TD	CC	DM	RC	SP	CW	MC	PG	CN	GC	CS	TO	TS	ST	MN	ED (pr)	AF	(mbox/	dl/	md)	
1	Un	Un	5	100	100	L	N	SY	N	B	A	N	Y	N	N	N	Y	1	30	Y	Y	Y	N	Y	X	-	-	-	-	-	-
2	Un	Un	3	100	100	L	N	U1	N	B	A	N	Y	N	N	N	Y	1	30	Y	Y	N	N	Y	X	-	-	-	-	-	-
3	Un	Un	3	100	100	L	N	U1	N	B	A	N	Y	N	N	N	Y	1	30	Y	Y	N	N	Y	X	-	-	-	-	-	-
.
63	30	30	6	100	100	L	N	SY	N	B	A	N	Y	N	-	-	-	-	-	-	-	-	-	-	X	-	-	-	-	-	
64	30	30	6	100	100	L	N	SY	N	B	A	N	-	-	-	-	-	-	-	-	-	-	-	-	-	-	-	-	-	-	

- | | | | |
|----------|---|------|---|
| COS: | Class of Service number | RtN: | New Message Retention (Un=Unlimited) |
| RtS: | Saved Message Retention Time (Un=Unlimited) | Ln: | Message Length Time (Un=Unlimited) |
| CaN: | Maximum Message | CaT: | Maximum Message Time (Un=Unlimited) |
| RO: | Message Retrieval Order (L=LIFO, F=FIFO) | SI: | Message Scanning with Information |
| Pr: | Prompt Mode (S=System Prompts, U1=User 1 Prompts, U2=User 2 Prompts) | DC: | Delete Message Confirmation |
| EV: | Envelope Information Position (B=before, A=after, N=none) | TD: | Time and Date Stamp Position (B=before, A=after, N=none) |
| CC: | Caller ID Callback | DM: | Direct Mailbox Access |
| RC: | Remote Call Forward to CO | SP: | Play System Prompt after Personal Greeting |
| CW: | Use Call Waiting on Busy | MC: | Message Cancel for Live Call Screening |
| PG: | Intercom Paging Group | CN: | Maximum number of names for Personal Caller Name Announcement |
| GC: | Play Personal Greeting for Caller ID | CS: | Caller ID Screening |
| TO: | Call Transfer to Outside | TS: | Toll Saver (D=DID, C=Caller ID, N=No) |
| ST: | Subscriber Tutorial | MN: | Authorization for Message Waiting Notification |
| ED (pr): | Authorization for External Message Delivery (Prompt Mode) (SY=System, U1=User 1, U2=User 2, SL=Selective) | AF: | Authorization for Auto Forwarding (mbox)=Mailbox No (dl)=Delay Time (md)=Forwarding Mode (M=move, C=copy) |

Note

An "X" displayed on the screen indicates that the feature marked with the X is set to "Yes".

7.3.3 System Service Report

The System Service Report provides information about the VPS's usable ports, trunk (CO line) groups and Holiday Services. It also indicates the services assigned to each VPS port and each trunk (CO line) group (for Day, Night, Lunch and Break modes), each Holiday Service, and all incoming and outgoing call services.

To select the System Service Report, follow the menu path as shown:

System Administration Top Menu-2-1-3

```

** System Service Report                                     PR- 9-2001 11:31 AM**
  Port  [Day mode]    [Night mode]    [Lunch mode]    [Break mode]
      Grt  Srv      Grt  Srv      Grt  Srv      Grt  Srv
  1  SYS  A.A.      SYS  A.A.      SYS  A.A.      SYS  A.A.
  2  SYS  A.A.      SYS  A.A.      SYS  A.A.      SYS  A.A.
  3  SYS  A.A.      SYS  A.A.      SYS  A.A.      SYS  A.A.
  4  SYS  A.A.      SYS  A.A.      SYS  A.A.      SYS  A.A.
  5  SYS  A.A.      SYS  A.A.      SYS  A.A.      SYS  A.A.
  6  SYS  A.A.      SYS  A.A.      SYS  A.A.      SYS  A.A.
  7  SYS  A.A.      SYS  A.A.      SYS  A.A.      SYS  A.A.
  8  SYS  A.A.      SYS  A.A.      SYS  A.A.      SYS  A.A.
  9  SYS  A.A.      SYS  A.A.      SYS  A.A.      SYS  A.A.
 10  SYS  A.A.      SYS  A.A.      SYS  A.A.      SYS  A.A.
 11  SYS  A.A.      SYS  A.A.      SYS  A.A.      SYS  A.A.
 12  SYS  A.A.      SYS  A.A.      SYS  A.A.      SYS  A.A.
 13  SYS  A.A.      SYS  A.A.      SYS  A.A.      SYS  A.A.
 14  SYS  A.A.      SYS  A.A.      SYS  A.A.      SYS  A.A.
 15  SYS  A.A.      SYS  A.A.      SYS  A.A.      SYS  A.A.
 16  SYS  A.A.      SYS  A.A.      SYS  A.A.      SYS  A.A.
 17  SYS  A.A.      SYS  A.A.      SYS  A.A.      SYS  A.A.
 18  SYS  A.A.      SYS  A.A.      SYS  A.A.      SYS  A.A.
 19  SYS  A.A.      SYS  A.A.      SYS  A.A.      SYS  A.A.
 20  SYS  A.A.      SYS  A.A.      SYS  A.A.      SYS  A.A.
 21  SYS  A.A.      SYS  A.A.      SYS  A.A.      SYS  A.A.
 22  SYS  A.A.      SYS  A.A.      SYS  A.A.      SYS  A.A.
 23  SYS  A.A.      SYS  A.A.      SYS  A.A.      SYS  A.A.
 24  SYS  A.A.      SYS  A.A.      SYS  A.A.      SYS  A.A.

  Trunk [Day mode]    [Night mode]    [Lunch mode]    [Break mode]
      Grt  Srv      Grt  Srv      Grt  Srv      Grt  Srv

  [Holiday List]
  Name of Holiday      Start  End  Grt  Srv  Port  Trunk
  NEW YEAR DAY        JAN- 1  .   15  C.S. (100)  1-24  1-48
  SPRING HOLIDAY      MAR-24 APR-5 16  C.S. (99)  1-24  1-48

```

V.M.: Voice Mail Service C.S.: Custom Service
 A.A.: Automated Attendant I.S.: Interview Service
 Service
 Grt: Company Greeting

Trunk data (Trunk 1 is shown above) is shown only when 1 (or more) service mode is not NONE. By default, all trunks for all modes are NONE.

Note

The maximum number of ports depends on the VPS model.

7.3.4 Call Account Report

The VPS can store information for up to 1092 outgoing calling sequences (for accounting and billing purposes). Outgoing calling information includes the mailbox numbers that executed outgoing calls, the telephone numbers called, the call dates, and call duration times. When the number of outgoing calling sequences reaches 1092, the first 84 items are automatically deleted. Any information sent to the terminal is automatically deleted from the system's memory.

To select the Call Account Report, follow the menu path as shown:

System Administration Top Menu-2-1-4

```
** Call Account                               NOV-5-2001 11:07 AM**
MBOX:1011 ED NOV-4 2:57 PM 00:00:42 DIAL:8301002
MBOX:1016 MN NOV-4 2:57 PM 00:00:42 DIAL:8301002
MBOX:1014 CC NOV-4 2:58 PM - : - : - DIAL:12345678901234567890123456789012
```

ED: External Message Delivery MN: Message Notification
CC: Caller ID Callback

Note

Depending on PBX extension numbering, the mailbox numbers might be 2- to 5-digit long.

7.3.5 Call Account Report Clear

The Call Account Report can be cleared for use again.

To clear the Call Account Report, follow the menu path as shown:

System Administration Top Menu-2-2-1

System Reports - System Report Clear - Call Account Report Clear

May I clear call account report data? (Y/N) : =

Type [Y] (yes) or **[N]** (no). If "Y" is entered, the system will clear the data. Wait until "Port Usage Report Data Cleared!!" appears on the screen before proceeding.

7.3.6 Port Usage Report

The Port Usage Report provides information about port usage and allows system and port traffic to be measured. The report includes the accumulated duration times of incoming and outgoing calling services and the total connect time for each port.

To select the Port Usage Report, follow the menu path as shown:

System Administration Top Menu-2-1-5

** Port Usage Report				FEB-21-2001 12:10 PM**	
FROM : : FEB-13-2001 6:08 PM					
Port	ED	MN	Rcv	Connect Time	
1	1	6	105	01:43:34	
2	4	3	8	00:03:41	
3	0	0	1	00:00:02	
4	0	0	1	00:00:01	
5	1	2	2	00:01:03	
6	1	2	0	00:00:55	
7	0	0	0	00:00:00	
8	0	0	0	00:00:00	
9	0	0	0	00:00:00	
10	0	0	0	00:00:00	
11	0	0	0	00:00:00	
12	0	0	0	00:00:00	
13	0	0	1	00:00:01	
14	0	0	0	00:00:00	
15	0	0	0	00:00:00	
16	0	0	0	00:00:00	
17	0	0	0	00:00:00	
18	0	0	0	00:00:00	
19	0	0	0	00:00:00	
20	0	0	0	00:00:00	
21	0	1	3	00:00:28	
22	0	0	0	00:00:00	
23	0	0	0	00:00:00	
24	0	0	0	00:00:00	
Total	7	14	121	01:49:45	
Full-line Time 00:00:00					

FROM: The date and time of the last clearing of this report
 ED: External Delivery MN: Message Notification Rcv: Receive
 Full-line Time: The total time that all ports were used simultaneously.

Note

The maximum number of ports depends on the VPS model.

7.3.7 Port Usage Statistics Clear

The Port Usage Report can be cleared for use again.

To clear the Port Usage Statistics Report, follow the menu path as shown:

System Administration Top Menu-2-2-2

System Reports - System Report Clear - Port Usage Statistics Clear

May I clear port usage report data? (Y/N) : =

Type [Y] (yes) or **[N]** (no). If "Y" is entered, the system will clear the data. Wait until "Port Usage Report Data Cleared!!" appears on the screen before proceeding.

7.3.8 Disk Usage Report

The Disk Usage Report indicates the amount of disk storage used and the disk availability in minutes. It also presents the following statistics:

- The number of messages that were recorded by callers and were copied since the last clearing of this report.
- The number of messages that were copied since the last clearing of this report.
- The number of messages that were deleted by subscribers, and expired and were removed by the system since the last clearing of this report.
- The number of messages that expired and were removed by the system since the last clearing of this report.

To select the Disk Usage Report, follow the menu path as shown:

System Administration Top Menu-2-1-6

** Disk Usage Report		MAR-29-2001 1:32 PM**			
Drive	Avail	Used	(%)		
1	3916 min	0min	(0)		
FROM : :	JAN-29-2001 1:25 PM				
	New	Cpy	Del	Exp	
MSGs	0	0	0	0	

FROM: The date and time of the last clearing of this report

Cpy: Copy (Transfer) Del: Deleted Exp: Expired and Removed

Note

The maximum available recording time depends on the VPS model.

7.3.9 Disk Usage Statistics Clear

The Disk Usage Report can be cleared of all values and prepared for use again.

To clear the Disk Usage Report, follow the menu path as shown:

System Administration Top Menu-2-2-3

System Reports - System Report Clear - Disk Usage Statistics Clear

May I clear disk usage report data ? (Y/N) : =

Type [Y] (yes) or **[N]** (no). If "Y" is entered, the system will clear the data. Wait until "Disk Usage Report Data Cleared!!" appears on the screen before proceeding.

7.3.10 Mailbox Usage Report

The Mailbox Usage Report provides information about the usage at specific mailbox. It includes the number of recorded messages, the total amount of outgoing calling time, and external message, message notification and group message delivery.

To select the Mailbox Usage Report, follow the menu path as shown:

System Administration Top Menu-2-1-7

Enter the Range : = 1111

Note

Specify the range or the mailbox number. To obtain information on specific mailboxes from No.2000 to No.2009, Type [200*] and Press RETURN, or [2000] [,] [2009] and Press RETURN.

** Mailbox Usage Report		NOV-27-2002 4:47 PM**			
MBOX:1111 [JONE BLUE]					
New	MSGs	4			
Received	MSGs	6			
ED	MSGs	0			
FROM : :		SEP-30-2002 7:51 PM			
Subscriber Access Information					
Last Access		::NOV-28-2002 2:56 PM			
Total Access Time		::00:00:35			
Number of Password Entry Failure		::123			
Feature Usage	ED	MN	IM	GM	AF
	11	31	20	14	22
Outcalling	LD	Lcl	Beep	Extn.	
(Time)	6	13	0	28	
	00:05:10	00:10:45	00:00:00	00:31:21	
MSG Received	Rcv	Del	Exp		
	42	30	11		

FROM: The date and time of the last clearing of this report
 MN: Message Notification
 GM: Personal/System Group Distribution List
 LD: Long distance call (8 digits or more)
 Lcl: Local call (less than 8 digits)
 Del: Deleted

ED: External Delivery
 IM: Interview message
 AF: Auto Forwarding

Rcv: Received
 Exp: Expired

Note

New MSGs, Received MSGs, and ED MSGs are current status indications. All else are accumulated indications since the last clearing of this report.

7.3.11 Mailbox Usage Statistics Clear

The Mailbox Usage Report can be cleared of all values and prepared for use again.

To clear the Mailbox Usage Report, follow the menu path as shown:

System Administration Top Menu-2-2-4

System Reports - System Report Clear - Mailbox Usage Statistics Clear

Enter the Range : =

May I clear mailbox usage report data ? (Y/N) : =

Type [Y] (yes) or **[N]** (no). If "Y" is entered, the system will clear the data. Wait until "Mailbox Usage Report Data Cleared!!" appears on the screen before proceeding.

7.3.12 Fax Call Report

The Fax Call Report provides information about fax transfer when the VPS receives a fax signal. It includes the fax data receiving date, the port number used, and the fax transfer status for up to 64 fax messages.

To select the Fax Call Report, follow the menu path as shown:

System Administration Top Menu-2-1-8

** Fax Call Report

NOV-14-2001 3:50 PM**

[DATE/TIME]	[PORT]	[FAX-1]	[FAX-2]
JAN-11 11:15 AM	1	connect	—
MAR-01 07:58 PM	2	(busy)	(no-ans.)
MAR-01 10:23 AM	1	(busy)	connect
.	.	.	.

FAX-1: Main facsimile machine

FAX-2: Alternate facsimile machine

connect: Call was answered by the facsimile machine no-ans.: No Answer

7.3.13 Fax Call Statistics Clear

The Fax Call Report can be cleared of all values and prepared for use again.

To clear the Fax Call Statistics Report, follow the menu path as shown:

System Administration Top Menu-2-2-5

System Reports - System Report Clear - Fax Call Report Clear

May I clear fax call report data ? (Y/N) :=

Type [Y] (yes) or **[N]** (no). If "Y" is entered, the system will clear the data. Wait until "Fax Call Report Data Cleared!!" appears on the screen before proceeding.

7.4 REMOTE PROGRAMMING (KX-TVS325 Only)

There are 2 methods available for VPS programming:

- **Method 1—On-Site Programming Using RS-232C**
Connect the programming terminal with a serial cable with an RS-232C connector to the VPS (see 2.8 TERMINAL CONNECTION).
- **Method 2—Remote Programming**
You can perform programming and maintenance from a remote location by accessing the internal modem card.

This section provides important information about Remote Programming.

Below is an example of the display that will appear when you access the VPS from a remote location.

Screen output:

```
Atdt91234567
CONNECT 33600/LAPM/NONE

Terminal Connected

Enter the Administrator Password :=

Please Select Your Terminal Type.
  1. ASCII TERMINAL
  2. VT100
Please Enter the Number :=
```

If the access to the internal modem of the VPS is successfully established, the display will show "Terminal Connected" as in the example above.

The maximum data transfer rate of the internal modem is 33600 bps.

When you access from a remote location, keep in mind the following:

1. **You cannot perform the On-Site Programming and Remote Programming at the same time.**

If you try to establish remote access while On-Site Programming is in progress, the access will be denied and the display will show "Another Terminal Connected".

To establish remote access, the screen for the System Administrator using the RS-232C connection must be as below:

```
>
```

Likewise, access via RS-232C will be denied while remote access is established; the display will show the same message, "Another Terminal Connected".

2. After terminating the remote access, the VPS will automatically initialize the internal modem. It is not possible to re-access during the initialization (about 30 s). If you try to re-establish the remote access during the initialization period, the display will show "Another Terminal Connected". Please retry after waiting for a while.

3. When activating the following 2 features, the VPS will automatically restart at the end of the procedure. Therefore, the access to the internal modem will be disconnected.

- Quick Setup
- System Reset/Clear

After the system has restarted, it is necessary to re-establish the remote access to the internal modem.

7.5 TROUBLESHOOTING GUIDE

Table 7-5

PROBLEM	PROBABLE CAUSE	POSSIBLE SOLUTION
<i>Nothing is heard from the VPS when accessing the VPS.</i>	<ul style="list-style-type: none"> • Improper connection of jacks. • Bad connection with PBX. 	<ul style="list-style-type: none"> • Confirm that you are using the correct extension number for the VPS. Ask your System Administrator. • Check if the jacks of the VPS are connected to the proper jacks of the PBX (see 1.4 VOICE MAIL INTEGRATION). • Check the "1-4 VPS (DPT) Port Assignment" screen of the KX-TD500, System Program [117] of other KX-T series telephone systems, or the "3.Groups-7.VM(DPT) Group-2.Unit Setting" and "1.Configuration-8.Extension Port" screens of KX-TDA/TAW series telephone systems that use DPT Integration to see if the programming agrees with the actual connection.
<i>Unable to utilize some of the DPT Integration features, even though DPT Integration has been established properly.</i>	<ul style="list-style-type: none"> • Your PBX cannot support the feature. • The software version of your PBX is lower than required. 	<ul style="list-style-type: none"> • Call National Parts Center at 1-800-833-9626.
<i>The VPS does not operate.</i>	<ul style="list-style-type: none"> • Bad printed circuit board. • Bad connection with PBX. • Incomplete card insertion. 	<ul style="list-style-type: none"> • Change the printed circuit board. • Check the connection between the VPS and PBX. • Insert the card firmly into the card slot.
<i>Dialing is not registered.</i>	<ul style="list-style-type: none"> • A pulse phone is being used by mistake. • Improper setting of integration mode. 	<ul style="list-style-type: none"> • Change to a touch tone phone. • Adjust the integration mode properly between the VPS and your PBX (see "Integration Mode" in Table B-43 in B7.3 PBX Interface Parameters).

Table 7-5

PROBLEM	PROBABLE CAUSE	POSSIBLE SOLUTION
<p><i>Line disconnection occurs while transferring an outside call.</i> <i>Unable to transfer an outside call.</i></p>	<ul style="list-style-type: none"> • Improper setting of the sequence. • Improper setting of the hooking time. • Improper setting of the CPC signal. • "Transfer to CO" not enabled on PBX. 	<ul style="list-style-type: none"> • Adjust the transfer sequence to that of the connected PBX and reset (see "Operator Transfer Sequence" and "Extension Transfer Sequence" in Table B-45 in B7.3 PBX Interface Parameters). • Adjust the hooking time to that of the connected PBX and reset (see "Flash Time" in Table B-41 in B7.2 Port Setting). • Adjust the CPC signal to that of the connected PBX and reset (see "CPC Signal" in Table B-41 in B7.2 Port Setting).
<p><i>Unable to call an outside party.</i></p>	<ul style="list-style-type: none"> • Improper setting of the outside call dial procedure. 	<ul style="list-style-type: none"> • Reset the CO line access sequence of the connected PBX (see "Dial Number" in Table B-5 in B2 SYSTEM ADMINISTRATION—MAILBOXES and "Number of Digits to Access Outside Line" in Table B-32 in B6.8 Other Parameters). • Also check "Outgoing Call Setup Sequence" in Table B-32 in B6.8 Other Parameters. • When setting a Dial Number for Device Notification or a telephone number for External Message Delivery, keep in mind the "Notice" for "Dial Number" in Table B-5 in B2 SYSTEM ADMINISTRATION—MAILBOXES.
<p><i>Unable to call an extension.</i></p>	<ul style="list-style-type: none"> • Improper setting of extension numbering plan. 	<ul style="list-style-type: none"> • Adjust the extension numbering plan properly (see "Numbering Plan 1-16" in Table B-31 in B6.8 Other Parameters).

Table 7-5

PROBLEM	PROBABLE CAUSE	POSSIBLE SOLUTION
<i>Unable to access the mailbox.</i>	<ul style="list-style-type: none"> Improper setting of the mailbox number. 	<ul style="list-style-type: none"> Readjust the number of digits in the mailbox number (see "Mailbox Number" in Table B-3 in B2 SYSTEM ADMINISTRATION—MAILBOXES).
<i>Unable to access to Operator 1</i>	<ul style="list-style-type: none"> Improper setting of the operator extension number. 	<ul style="list-style-type: none"> Adjust the operator extension number to that of the connected PBX (see "Operator's Extension" in Table B-12 in B5.1 Automated Attendant Parameters).
<i>Connected terminal (RS-232C port) does not operate.</i>	<ul style="list-style-type: none"> Improper connection. Improper setting of the parameter. 	<ul style="list-style-type: none"> Be sure you are using a null modem cable (see 2.8 TERMINAL CONNECTION). The terminal and VPS should have the same parameter settings for Baud Rate, Word Bit Length, Parity and Stop Bit Length (see B7.1 RS-232C Parameters).
<i>Unable to make reconnection when the line is busy.</i>	<ul style="list-style-type: none"> Improper setting of the busy signal reconnection procedure. 	<ul style="list-style-type: none"> Readjust the busy signal reconnection procedure to that of the connected PBX (see "Reconnect Sequence on Busy" in Table B-45 in B7.3 PBX Interface Parameters).
<i>Unable to make a no-response reconnection.</i>	<ul style="list-style-type: none"> Improper setting of the no-response reconnection procedure. 	<ul style="list-style-type: none"> Readjust the no-response reconnection procedure to that of the connected PBX (see "Reconnect Sequence on No Answer" in Table B-45 in B7.3 PBX Interface Parameters).
<i>Unable to generate a call waiting tone from the VPS.</i>	<ul style="list-style-type: none"> Improper setting of sequence. 	<ul style="list-style-type: none"> Adjust the Call Waiting sequence to that of the connected PBX (see "Call Waiting Sequence" in Table B-45 in B7.3 PBX Interface Parameters).
<i>Unable to make an Intercom Paging for groups.</i>	<ul style="list-style-type: none"> Improper setting of the Intercom Paging access code. 	<ul style="list-style-type: none"> Adjust the Intercom Paging access code to that of the connected PBX (see "Paging Code for Group 1-16" and "Paging Code for All Groups" in Table B-37 in B6.8 Other Parameters).

7.6 SPECIFICATIONS

Table 7-6

Port Cards:		KX-TVS102 (2 digital/analog port expansion card) and KX-TVS204 (4 digital port expansion card)
Dialing Method:		Touchtone/Pulse (10/20 pps)
Flash Time:		100 ms/300 ms/600 ms/900 ms (programmable)
CPC Detection		None/6.5 ms/150 ms/300 ms/450 ms/600 ms (programmable)
Type of Line:		Loop start minimum Loop Current: 20 mA minimum Line Voltage: 7 V DC minimum Ringing Voltage: 40 V AC
Extension Numbering:		2 to 5 digits (programmable)
Pause Time:		1 s to 9 s (programmable)
Message Waiting Lamp:		Programmable Touchtone sequence
Main CPU:		16-bit microprocessor
Hard Disk Capacity:		<ul style="list-style-type: none"> • KX-TVS125: Approximately 32 h • KX-TVS225: Approximately 64 h • KX-TVS325: Approximately 128 h
Number of Mailboxes:		<ul style="list-style-type: none"> • KX-TVS125: Maximum 64 • KX-TVS225 and KX-TVS325: Maximum 1024 (including System Manager and Message Manager mailboxes)
Number of Messages:		Maximum 100 per mailbox (programmable)
Personal Greeting Message Length:		6 min
Message Retention Time:		1 to 30 days or unlimited (programmable)
Maximum Message Length:		1 min to 6 min, or unlimited length (programmable)
Reports:		Mailbox Assignment, COS (Class of Service) Assignment, System Service Report, Call Account Report, Port Usage Report, Disk Usage Report, Mailbox Usage Report, FAX Call Report
Connections	Telephone Line:	In case of Inband: <ul style="list-style-type: none"> • KX-TVS125: 2-conductor cable × 4 • KX-TVS225: 2-conductor cable × 6 • KX-TVS325: 2-conductor cable × 12 In case of DPT: <ul style="list-style-type: none"> • KX-TVS125: 4-conductor cable with DPT interface × 3 • KX-TVS225: 4-conductor cable with DPT interface × 6 • KX-TVS325: 4-conductor cable with DPT interface × 12
	Data Port:	RS-232C interface port

Table 7-6

Operating Temperature:	Please see Table 2-1 Hard Disk Drive Usage Environment in 2.1.3 Environmental Requirements.
Operating Relative Humidity:	Please see Table 2-1 Hard Disk Drive Usage Environment in 2.1.3 Environmental Requirements.
Power Source:	120 V AC, 60 Hz
Power Consumption:	<ul style="list-style-type: none"> • KX-TVS125: Approximately 25 W (with 1 KX-TVS204 card and 1 KX-TVS102 card) • KX-TVS225: Approximately 30 W (with 3 KX-TVS204 cards) • KX-TVS325: Approximately 45 W (with 6 KX-TVS204 cards)
Dimensions (H × W × D):	470 mm × 335 mm × 110 mm {18-1/2" × 13-3/16" × 4-21/64"}
Mass (Weight):	<ul style="list-style-type: none"> • KX-TVS125: Approximately 5.2 kg {11.46 lb} (with 1 KX-TVS204 card installed at the factory) • KX-TVS225: Approximately 5.0 kg {11.02 lb} (with 1 KX-TVS204 card installed at the factory) • KX-TVS325: Approximately 5.3 kg {11.68 lb} (with 1 KX-TVS204 card installed at the factory)

Appendix A

SYSTEM FEATURES

A1 SYSTEM FEATURES

The Voice Processing System has many features that are available to the System Administrator, the System Manager, and/or System Subscribers. The Table A-1 lists and briefly describes each key VPS system feature. In addition, references to specific sections of this manual and the Subscriber's Guide are provided in the references column that pertains to each feature listed. The specific procedure steps required to initiate, access, or utilize each feature are detailed at these references.

Note

Depending on the model and/or the software version of the connected PBX, you may not be able to utilize some of the features available only with DPT Integration. For more information, call National Parts Center at 1-800-833-9626.

Table A-1

FEATURE	DESCRIPTION	REFERENCES
Alternate Extension Group	a group of extensions, which require a different call transfer sequence than normal, placed into a separate group.	<ul style="list-style-type: none"> See "Dialing Parameters" in 3.2.4 PBX Interface Parameters. See "Alternate Extension Assignment" in B5.1 Automated Attendant Parameters. See "Alternate Extension Group" in the Glossary.
Auto Configuration (DPT Integration Only)	creates mailboxes by obtaining extension numbers from the Panasonic KX-T series telephone system that uses DPT Integration. Also sets the time and date automatically by obtaining time information from the PBX.	<ul style="list-style-type: none"> See "System Components" in 1.3.2 System Components. See 4.1 GUIDELINES FOR DPT INTEGRATION. See "Creating Mailboxes" in 5.1.3 Starting the Quick Setup. See "The length of mailbox numbers" in 5.1.3 Starting the Quick Setup. See "Auto Configuration" in the Glossary.
Auto Forwarding	moves or copies unretrieved messages from one mailbox to another, after a specified period of time. This service is only available to subscribers (you cannot auto forward messages to the System Group Distribution Lists). Class of Service programming determines the mailboxes that can use this feature. Messages marked as "private" cannot be forwarded. Also, a message is never forwarded to the original sender of the message.	<ul style="list-style-type: none"> See "Private Message" in this Table. See "Authorization for Auto Forwarding" in Table B-7 in B3 SYSTEM ADMINISTRATION—SETTING COS (CLASS OF SERVICE) PARAMETERS. See C3 SETTING COS (CLASS OF SERVICE) PARAMETERS. See "Auto Forwarding" in the Glossary.

Table A-1

FEATURE	DESCRIPTION	REFERENCES
Automated Attendant	answers incoming calls and routes those calls to the desired extension. The service can be assigned to all of Day, Night, Lunch, and Break time periods. Available for both Port and Trunk Services.	<ul style="list-style-type: none"> • See 5.2.10 Automated Attendant. • See 5.4 AUTOMATED ATTENDANT PARAMETERS. • See B5.1 Automated Attendant Parameters. • See "Automated Attendant" in the Glossary.
Broadcasting Messages	permits the System Manager to deliver the same message to all VPS subscribers at the same time. This feature is only available to the System Manager.	<ul style="list-style-type: none"> • See "Delivering Messages to All Mailboxes (Broadcasting Messages)" in C9 DELIVERING MESSAGES.
Busy Coverage Mode	specifies how the VPS will handle calls to the operator when the line is busy. The Busy Coverage options that are available include: Hold, No Answer Coverage, Call Waiting, and Disconnect Message.	<ul style="list-style-type: none"> • See "Busy Coverage Mode" in Table 5-6 in 5.4.3 Operator's Parameters. • See "Busy Coverage Mode" in Table B-12, Table B-13 and Table B-14 in B5 SYSTEM ADMINISTRATION—SERVICE SETTINGS.
Call Services	include a series of both incoming and outgoing call services. Incoming Call Services: Automated Attendant Service, Voice Mail Service, Interview Service, Custom Service. Outgoing Call Services: Message Waiting Notification, and External Message Delivery.	<ul style="list-style-type: none"> • See "Port Service Setting" in 5.1.3 Starting the Quick Setup. • See "Incoming Call Service" in Table 5-5 in 5.3.1 Port Service Menu. • See "Incoming Call Service" in Table B-9 in B4.1 Port Assignment. • See "Incoming Call Service" in Table B-10 in B4.2 Trunk Group Assignment.
Call Transfer Status	permits subscribers to specify how the VPS will handle calls to their individual extensions. Call Transfer Status options include: Call Screening, Call Blocking, Intercom Paging, Calling a Beeper and Transfer to Mailbox.	<ul style="list-style-type: none"> • See "Calling a Beeper" and "Intercom Paging" in this Table. • See "Call Transfer" in the Glossary. • See 4.1 Call Transfer Status in the Subscriber's Guide.

Table A-1

FEATURE	DESCRIPTION	REFERENCES
<p>Callback Number Entry</p>	<p>enables the caller to leave a callback number in several different ways depending upon which option is programmed into the VPS. The VPS can forward the callback number to a beeper.</p>	<ul style="list-style-type: none"> • See "Notification Setting" in B2 SYSTEM ADMINISTRATION—MAILBOXES. • See "Beeper Callback No. Entry Mode" in Table B-7 and Table B-8 in B3 SYSTEM ADMINISTRATION—SETTING COS (CLASS OF SERVICE) PARAMETERS. • See "Other Parameters-Message Waiting Notification" in B6.8 Other Parameters. • See C3 SETTING COS (CLASS OF SERVICE) PARAMETERS.
<p>Caller ID Callback (DPT Integration Only)</p>	<p>enables a subscriber to call back a message sender with the Caller ID number attached to the message.</p>	<ul style="list-style-type: none"> • See "Transfer to Outside Parameters" in 3.2.4 PBX Interface Parameters. • See "Call Transfer to Outside" in this Table. • See "Caller ID Callback" in Table B-7 and Table B-8 in B3 SYSTEM ADMINISTRATION—SETTING COS (CLASS OF SERVICE) PARAMETERS. • See "Caller ID Callback" in Table B-51 in B7 SYSTEM ADMINISTRATION—HARDWARE SETTINGS. • See C3 SETTING COS (CLASS OF SERVICE) PARAMETERS. • See "Caller ID Callback" in the Glossary.
<p>Caller ID Call Routing (DPT Integration Only)</p>	<p>allows the System Administrator to assign up to 200 Caller ID numbers and program the route for the calls from these assigned numbers to the desired extension, mailbox (including System Group Distribution List) or Custom Service. The Company Greetings will not play when calls are routed as programmed by this feature.</p>	<ul style="list-style-type: none"> • See 4.1 GUIDELINES FOR DPT INTEGRATION. • See "Caller ID Call Routing" in B5.3 Intelligent Call Handling. • See "Caller ID Call Routing" in the Glossary.

Table A-1

FEATURE	DESCRIPTION	REFERENCES
Caller ID Screening (DPT Integration Only)	allows extension users to hear prerecorded caller names when calls from assigned numbers are transferred from the VPS to the extension users.	<ul style="list-style-type: none"> See "Caller Name Announcement—Personal" and "Caller Name Announcement—System" in this Table.
Caller Name Announcement—Personal (DPT Integration Only)	<p>allows subscribers to assign up to 30 Caller ID numbers and record a caller name for each Caller ID number from their telephone. The caller name is announced when: (1) subscribers listen to the messages from assigned numbers left in their mailboxes, (2) the VPS transfers calls from assigned numbers to the subscribers (Caller ID Screening), and (3) the VPS pages the subscribers by intercom (Intercom Paging). Caller ID Screening is enabled or disabled in the COS (Class of Service) settings.</p> <p>If the same Caller ID number is programmed for both the system and personal caller name announcement, the VPS will use the personal caller name.</p>	<ul style="list-style-type: none"> See 4.1 GUIDELINES FOR DPT INTEGRATION. See "Number of CIDs for Caller Name Announcement" and "Caller ID Screening" in Table B-7 in B3 SYSTEM ADMINISTRATION—SETTING COS (CLASS OF SERVICE) PARAMETERS. See C3 SETTING COS (CLASS OF SERVICE) PARAMETERS. See "Caller Name Announcement (System/Personal)" in the Glossary. See 4.12 Personal Caller Name Announcement in the Subscriber's Guide.
Caller Name Announcement—System (DPT Integration Only)	<p>allows the System Administrator to assign up to 120 Caller ID numbers. Each Caller ID number can have a caller name recorded by the Message Manager. The caller name is announced when: (1) extension users listen to the messages from assigned numbers left in their mailboxes, (2) the VPS transfers calls from assigned numbers to the subscribers (Caller ID Screening), and (3) the VPS pages the subscribers by intercom (Intercom Paging). Caller ID Screening is enabled or disabled in the COS (Class of Service) settings.</p> <p>If the same Caller ID number is programmed for both the system and personal caller name announcement, the VPS will use the personal caller name.</p>	<ul style="list-style-type: none"> See 4.1 GUIDELINES FOR DPT INTEGRATION. See "Caller ID Screening" in Table B-7 in B3 SYSTEM ADMINISTRATION—SETTING COS (CLASS OF SERVICE) PARAMETERS. See B6.6 System Caller Name Announcement. See C3 SETTING COS (CLASS OF SERVICE) PARAMETERS. See "Recording System Caller Names" in D6 RECORDING MESSAGES. See "Caller Name Announcement (System/Personal)" in the Glossary.

Table A-1

FEATURE	DESCRIPTION	REFERENCES
<p>Calling a Beeper</p>	<p>allows a subscriber to be notified by a beeper when he has message(s). If the beeper has a display, it is possible to send to it a callback number. The callback number can be recorded when a caller leaves a message. If the caller does not leave a callback number, the System Callback No., or the caller's number if it is received through a telephone company's Caller ID service, will be sent instead.</p> <p>To utilize this feature, follow the procedure below.</p> <p>1) Go to the System Administration Top Menu, and type 1-2 (Program-Class of Service) and COS No.(1-63). Select "Yes" in the Authorization for Message Notification parameter. Make 1 selection from the available options in the Beeper Callback No. Entry Mode parameter.</p> <p>2) From the System Administration Top Menu, type 1-1-1-Mailbox No.-Y-2-Device No.(1-3) (Program-Mailbox Setting-Enter/Edit-Mailbox No. Entry-Do you want to edit this mailbox?-Notification Setting-Device No. Entry). For the Dial Number parameter: enter your PBX's line access code before the beeper number for dialing outward; enter an X after the beeper number. (The X is for the caller to enter his number as the callback number which will later appear on your beeper.) Finally, select "Beeper" in the Type of Device parameter.</p>	<ul style="list-style-type: none"> • See "Dial Number" and "Type of Device" in Table B-5 in B2 SYSTEM ADMINISTRATION—MAILBOXES. • See "Authorization for Message Notification" and "Beeper Callback No. Entry Mode" in Table B-7 and Table B-8 in B3 SYSTEM ADMINISTRATION—SETTING COS (CLASS OF SERVICE) PARAMETERS. • See "System Callback No." in Table B-33 in B6.8 Other Parameters. • See C3 SETTING COS (CLASS OF SERVICE) PARAMETERS.

Table A-1

FEATURE	DESCRIPTION	REFERENCES
Call Transfer to Outside	<p>enables the VPS to transfer a call to an outside line from the following services:</p> <ul style="list-style-type: none"> • Custom Service • Call Transfer Service • Personal Custom Service • Caller ID Callback <p>Note</p> <p>This feature is not supported when the VPS is connected to the following PBXs:</p> <ul style="list-style-type: none"> • KX-TA624 • KX-TDA/KX-TAW series Version 1.0 (From Version 1.1, this feature will be supported.) 	<ul style="list-style-type: none"> • See "Call Transfer to Outside" in Table B-7 in B3 SYSTEM ADMINISTRATION—SETTING COS (CLASS OF SERVICE) PARAMETERS. • See "Transfer to Outside Parameters" in B7.3 PBX Interface Parameters. • See C3 SETTING COS (CLASS OF SERVICE) PARAMETERS. • See 4.17 Setting Telephone Numbers for Call Transfer to CO in the Subscriber's Guide.
Class of Service (COS)	<p>There are 62 COS levels for subscribers. COS 63 is for the Message Manager and COS 64 is for the System Manager.</p> <p>Either the System Administrator (using a personal computer) or the System Manager (using a telephone) can change COS assignments.</p>	<ul style="list-style-type: none"> • See 7.3.2 COS (Class of Service) Assignments. • See B3 SYSTEM ADMINISTRATION—SETTING COS (CLASS OF SERVICE) PARAMETERS. • See "Creating and Editing a Mailbox" in C2 SETTING UP MAILBOXES. • See C3 SETTING COS (CLASS OF SERVICE) PARAMETERS.
Company Greeting	<p>is a prerecorded message designed to greet all incoming callers and provide relevant information. This feature allows the use of up to 32 different greetings for each individual Time Service period (Day, Night, Lunch and Break) as well as holidays*. Available for both Port and Trunk services.</p> <p>Note</p> <p>The System Manager can change the Company Greeting setting remotely by simply calling the VPS (see C6 CHANGING THE COMPANY GREETING AND INCOMING CALL SERVICE SETTING).</p> <p>* Only the System Administrator can assign specific greetings for holidays.</p>	<ul style="list-style-type: none"> • See 6.1.3 Company Greetings (Enter #6*9998,5,1). • See C6 CHANGING THE COMPANY GREETING AND INCOMING CALL SERVICE SETTING. • See "Company Greeting No." in Table B-9 and Table B-10 in B4 SYSTEM ADMINISTRATION—PORT/TRUNK SERVICE. • See "Company Greeting No." in Table B-26 in B6.3 Holiday Setting. • See D6 RECORDING MESSAGES. • See "Company Greeting" in the Glossary.

Table A-1

FEATURE	DESCRIPTION	REFERENCES
Company Name	is used by External Message Delivery Service when the intended receiver enters the password incorrectly 3 times. The VPS announces the Company Name so that the receiver realizes what company placed the call to him.	<ul style="list-style-type: none"> • See D6 RECORDING MESSAGES. • See "Company Name" in the Glossary. • See 3.5 Receiving External Delivery Messages in the Subscriber's Guide.
Covering Extension	forwards calls to a second extension when the first extension's subscriber is not available to take the call. The caller can also access the Covering Extension by pressing [0] while a Personal Greeting is being played, or while leaving a message.	<ul style="list-style-type: none"> • See "Covering Extension" in Table B-4 in B2 SYSTEM ADMINISTRATION—MAILBOXES. • See "Covering Extension" in the Glossary. • See 4.2 Covering Extension in the Subscriber's Guide.
Custom Service	<p>allows callers to access specific functions by entering numbers or symbols through the telephone keypad.</p> <p>The Message Manager can record up to 100 Custom Service menus. These menus can be recorded in various foreign languages, and help guide outside callers to the desired extension, mailbox, System Group Distribution List, Department Dialing menu, operator, fax machine, etc.</p> <p>Note Callers cannot jump between Custom Service menus more than 8 times.</p>	<ul style="list-style-type: none"> • See 5.2 PORT SETTING OPTIONS. • See 6.1.4 Custom Service Greetings (Enter #6*9998,5,4). • See 7.2.11 Custom Service Report (CREP). • See 7.2.12 Custom Service Menu Access Count Clear (CCLR). • See B5.2 Custom Service. • See "Recording Menus and Voice Labels" in D6 RECORDING MESSAGES. • See "Custom Service Setting" in the Glossary.
Daylight Saving Time Assignment	changes the internal clock of the VPS for the start and end of Daylight Saving Time.	<ul style="list-style-type: none"> • See B6.4 Daylight Saving Time (DST).
Delete Message Confirmation	<p>requests confirmation from mailbox owner before erasing a message left in the mailbox.</p> <p>This feature can be enabled or disabled in the COS (Class of Service) settings.</p>	<ul style="list-style-type: none"> • See "Delete Message Confirmation" in Table B-7 and Table B-8 in B3 SYSTEM ADMINISTRATION—SETTING COS (CLASS OF SERVICE) PARAMETERS. • See C3 SETTING COS (CLASS OF SERVICE) PARAMETERS.

Table A-1

FEATURE	DESCRIPTION	REFERENCES
Department Dialing	is a speed-dialing feature that permits the caller to quickly reach the desired extension by dialing a 1 digit number either during or after the playing of the Department Dialing message.	<ul style="list-style-type: none"> • See 5.4.2 Department Dialing. • See "Department Dialing" in B5.1 Automated Attendant Parameters. • See "Recording Menus and Voice Labels" in D6 RECORDING MESSAGES. • See "Department Dialing" in the Glossary.
Dialing by Name	allows the caller to reach the intended mailbox/extension (when the number is not known) by entering the first 3 or 4 letters of the mailbox owner's last name. The VPS identifies all subscribers with that letter combination and states each name for the caller. The caller selects the desired subscriber by entering the appropriate number.	<ul style="list-style-type: none"> • See "Owner Last Name" in Table B-4 in B2 SYSTEM ADMINISTRATION—MAILBOXES.
DID Call Routing (DPT Integration Only)	<p>allows the System Administrator to assign up to 200 DID numbers and program the route for calls from these assigned numbers to the desired extension, mailbox (including System Group Distribution List) or Custom Service. It also forwards "Private" (the caller's number is not received) and "Out of Area" calls to a desired extension, mailbox or Custom Service.</p> <p>The Company Greetings will not play when calls are routed as programmed by this feature.</p> <p>Note</p> <p>This feature is only available when the VPS is connected to the following PBXs with DPT Integration.</p> <ul style="list-style-type: none"> • KX-TD816 (P311Q or higher) • KX-TD1232 (P211Q or higher) • KX-TD500 (V4M or higher) 	<ul style="list-style-type: none"> • See 4.1 GUIDELINES FOR DPT INTEGRATION. • See "DID Call Routing" in B5.3 Intelligent Call Handling. • See "DID Call Routing" in the Glossary.

Table A-1

FEATURE	DESCRIPTION	REFERENCES
<p>Direct Mailbox Access (DPT Integration Only)</p>	<p>allows subscribers to call the VPS and access their mailbox without entering the mailbox number.</p>	<ul style="list-style-type: none"> • See 4.1 GUIDELINES FOR DPT INTEGRATION. • See "Direct Mailbox Access" in Table B-7 in B3 SYSTEM ADMINISTRATION—SETTING COS (CLASS OF SERVICE) PARAMETERS. • See C3 SETTING COS (CLASS OF SERVICE) PARAMETERS. • See "Direct Mailbox Access" in the Glossary.
<p>DPT Integration</p>	<p>is the interface data link that permits certain information and command functions to be transmitted between the VPS and PBX. The information and command functions include: Remote Call Forwarding Set, Auto Configuration, Caller ID Call Routing, DID Call Routing, Caller Name Announcement (System/Personal), Direct Mailbox Access, Intercom Paging, Live Call Screening, Personal Greeting for Caller ID, Time Synchronization with PBX, Two-Way Record, Two-Way Transfer and Toll Saver.</p> <p>Note</p> <p>Depending on the model and/or the software version of the connected PBX, you may not be able to utilize some of the features available only with DPT Integration. For more information, call National Parts Center at 1-800-833-9626.</p>	<ul style="list-style-type: none"> • See "VOICE MAIL" in 1.3.3 Which Phone Systems are Compatible? • See 1.4 VOICE MAIL INTEGRATION. • See 2.7 CONNECTIONS. • See 3.1.1 DPT or Inband Signaling? • See Section 4 INTEGRATING THE VPS WITH THE PANASONIC KX-T DIGITAL PBX. • See "DPT Integration" in the Glossary.
<p>Extension Group</p>	<p>places several extensions into the same mailbox to share information using an Extension Group List. The System Administrator must establish this list. The VPS can maintain up to 20 lists with a maximum of 20 entries on each.</p>	<ul style="list-style-type: none"> • See 5.2.8 Extension Groups. • See "System Group Assignment-Extension Group" in B6.1 System Group Assignment.
<p>Extension Numbering Plan</p>	<p>permits the VPS to recognize an extension number as valid.</p>	<ul style="list-style-type: none"> • See "Other Parameters-Extension Numbering Plan" in B6.8 Other Parameters.

Table A-1

FEATURE	DESCRIPTION	REFERENCES
External Message Delivery List	<p>allows a subscriber to send a message to outside parties and/or extensions with a single operation. One subscriber can maintain up to 2 lists with a maximum of 8 entries on each.</p> <p>This feature is only available when External Message Delivery has been authorized for the subscriber's COS.</p>	<ul style="list-style-type: none"> • See "External Message Delivery Service" in this Table. • See "External Delivery Message", "External Message Delivery List", and "External Message Delivery Redial" in the Glossary. • See 3.3 Setting up an External Message Delivery List in the Subscriber's Guide.
External Message Delivery Service	<p>allows a subscriber to send a message to several subscribers and non-subscribers (including outside parties) at a specified time (or immediately). This feature also permits the receiver to reply to the message without having to specify the mailbox number.</p> <p>If the sender wishes, he can require the receiver to enter a 4-digit password to receive the sender's message. If the receiver enters the password incorrectly 3 times, the VPS: (1) plays the Company Name (if it has been recorded), (2) plays the Company's Telephone Number (if registered), and (3) plays the sender's extension (if both the Company's Telephone Number and the Extension of the Owner have been registered). With this information, the receiver can possibly track down the message even if he does not remember the password.</p> <p>COS programming determines whether this feature can be used or not.</p>	<ul style="list-style-type: none"> • See "The Extension of the Owner" in Table B-4 in B2 SYSTEM ADMINISTRATION—MAILBOXES. • See "Authorization for External Message Delivery" in Table B-7 in B3 SYSTEM ADMINISTRATION—SETTING COS (CLASS OF SERVICE) PARAMETERS. • See "Other Parameters-External Message Delivery" in B6.8 Other Parameters. • See C3 SETTING COS (CLASS OF SERVICE) PARAMETERS. • See "External Delivery Message", "External Message Delivery List", and "External Message Delivery Redial" in the Glossary. • See 3.4 Sending External Delivery Messages in the Subscriber's Guide. • See 3.5 Receiving External Delivery Messages in the Subscriber's Guide. • See 3.6 Replying to External Delivery Messages in the Subscriber's Guide.

Table A-1

FEATURE	DESCRIPTION	REFERENCES
<p>External Message Delivery Status</p>	<p>allows the subscriber to check the status of undelivered and pending external delivery messages.</p> <p>This feature is only available when External Message Delivery has been authorized for the subscriber's COS.</p>	<ul style="list-style-type: none"> • See "External Message Delivery Service" in this Table. • See "External Delivery Message", "External Message Delivery List", and "External Message Delivery Redial" in the Glossary. • See 3.7 Checking and Setting External Message Delivery Status in the Subscriber's Guide.
<p>Fax Management</p>	<p>allows the VPS to automatically route an incoming fax signal to a specific fax machine. Up to 2 fax machines can be assigned using this feature. Outside callers can also reach the fax machine via Custom Service selection, if programmed.</p> <p>A special mailbox can be assigned to the Fax Manager. In this way, the VPS can notify the Fax Manager of the status of faxes.</p>	<ul style="list-style-type: none"> • See "Fax Management (1-5-8-8)" in 5.2.2 Custom Service Features. • See 7.3.12 Fax Call Report. • See 7.3.13 Fax Call Statistics Clear. • See "Other Parameters-Fax Management" in B6.8 Other Parameters.
<p>Group Distribution List—Personal</p>	<p>allows a subscriber to simultaneously send a message to several mailboxes using a Group Distribution List. This list is established by the subscriber. Each subscriber can maintain a maximum of 4 lists with up to 20 entries on each list.</p>	<ul style="list-style-type: none"> • See "Group Distribution List—System" in this Table. • See "Personal Group Distribution List" in the Glossary. • See 4.5 Personal Group Distribution Lists in the Subscriber's Guide. • See 4.6 Deleting Group Distribution Members in the Subscriber's Guide. • See 4.7 Deleting Group Distribution List Names in the Subscriber's Guide.
<p>Group Distribution List—System</p>	<p>allows a subscriber to send a message to several mailboxes using a Group Distribution List. Also allows a caller to record a message into all mailboxes within the list. The System Administrator must establish this list. The VPS can maintain up to 20 lists with a maximum of 20 entries on each.</p>	<ul style="list-style-type: none"> • See "System Group Assignment-Mailbox Group" in B6.1 System Group Assignment. • See C9 DELIVERING MESSAGES. • See "System Group Distribution List" in the Glossary.

Table A-1

FEATURE	DESCRIPTION	REFERENCES
Hold	provides the caller with the option of temporarily holding the call when the line is busy. The VPS automatically recalls the extension after a specified period of time. When several callers hold their calls to the same extension, callers are connected in the order in which they originally called.	<ul style="list-style-type: none"> See "Other Parameters-Call Hold" in B6.8 Other Parameters.
Holiday Service	<p>permits the VPS to record, store, and play several different holiday greetings. Up to 20 Holiday Service settings can be programmed.</p> <p>It is possible to either specify a single day or a range of days on which to enable the Holiday Service setting.</p> <p>Note Holidays cannot overlap.</p>	<ul style="list-style-type: none"> See B6.3 Holiday Setting.
Inband Integration	allows the PBX, using Inband Integration, to send information to the VPS using Touchtones. Inband integration is characterized as Voice Mail Integration and Touchtone Integration. Voice Mail Integration works with the Call Forwarding Feature of the PBX to permit a caller to leave a message when the mailbox number of the called extension is not known. Touchtone Integration works with the Automated Attendant Service to enable the VPS to immediately recognize the state of the call (busy, answered, ringing, etc.) and improve its call handling performance.	<ul style="list-style-type: none"> See "VOICE MAIL" in 1.3.3 Which Phone Systems are Compatible? See 1.4 VOICE MAIL INTEGRATION. See 2.7 CONNECTIONS. See 3.1.1 DPT or Inband Signaling?. See Section 3 INTEGRATING THE VPS WITH PANASONIC KX-T PHONE SYSTEMS. See "Inband Signaling" in the Glossary.
Incomplete Call Handling Service	allows the subscriber to offer callers several service options when the extension is busy or there is no answer: Leaving a Message, Transfer to Covering Extension, Returning to the Automated Attendant Top Menu, Intercom Paging, Calling a Beeper, or Calling Operators.	<ul style="list-style-type: none"> See "Calling a Beeper" and "Intercom Paging" in this Table. See "Incomplete Call Handling Service" in the Glossary. See 4.3 Incomplete Call Handling Status in the Subscriber's Guide.

Table A-1

FEATURE	DESCRIPTION	REFERENCES
<p>Intercom Paging (DPT Integration Only)</p>	<p>permits callers to page subscribers by PBX paging (there are different kinds of PBX paging, and these can be specified by VPS programming) when the subscribers have set Intercom Paging for Call Transfer or when the subscribers have set Intercom Paging for Incomplete Call Handling. The caller is briefly placed on hold while the VPS announces the page and until the subscriber answers the page. The subscriber can answer the page from any extension using the paging answer code; this code is specified in the PBX User Manual. For a Caller ID Caller, if his name has been recorded for the Caller Name Announcement feature, the name will be announced at the end of the page. If the caller's name has been recorded for both the System and Personal Caller Name Announcement, the VPS will use the personal caller name.</p> <p>To utilize this feature, follow the procedure below.</p> <p>1) Go to the System Administration Top Menu, and type 1-2 (Program-Class of Service) and COS No.(1-62). Select an Intercom Paging Group (1-17) for this COS. If set to Group 17, the Intercom Paging feature is activated for all groups.</p> <p>2) From the System Administration Top Menu, type 1-5-8-7 (Program-System Parameter Setting-Others-Intercom Paging Parameters). Adjust the "No Answer Time for Intercom Paging" to your preference (the default is 5 s). For the Intercom Paging Group you selected in Step 1, set the Intercom Paging access code in "Paging Code for Group 1-16" and "Paging Code for All Groups".</p>	<ul style="list-style-type: none"> • See 4.1 GUIDELINES FOR DPT INTEGRATION. • See "Intercom Paging (1-5-8-7)" in 5.2.2 Custom Service Features. • See "Intercom Paging Group" in Table B-7 in B3 SYSTEM ADMINISTRATION—SETTING COS (CLASS OF SERVICE) PARAMETERS. • See "Other Parameters-Intercom Paging Parameter" in B6.8 Other Parameters. • See "Intercom Paging" in the Glossary.

Table A-1

FEATURE	DESCRIPTION	REFERENCES
Interview Service	plays a set of recorded questions when a caller accesses the service. The caller is provided an opportunity to answer each question after it has been asked. Subscribers are able to record questions directly into their own Interview Mailbox.	<ul style="list-style-type: none"> • See 5.2.9 Interview Service. • See "Interview Mailbox Number" in Table B-4 in B2 SYSTEM ADMINISTRATION—MAILBOXES. • See "Creating and Editing a Mailbox" in C2 SETTING UP MAILBOXES. • See "Interview Service" in the Glossary. • See 4.9 Interview Mailbox in the Subscriber's Guide.
Live Call Screening (DPT Integration Only)	<p>permits the subscriber to monitor incoming calls as messages are being recorded. The subscriber has the option of answering calls while monitoring or allowing the message to be recorded without interruption. There are two modes in this feature: Hands-free and Private.</p> <p>Hands-free permits the subscriber to hear the caller through the telephone's speaker and answer the call by lifting the handset. The Private Mode alerts by tone and requires the telephone handset to be lifted before the message can be monitored. Two-way communication is established by pressing the feature button.</p>	<ul style="list-style-type: none"> • See 4.1 GUIDELINES FOR DPT INTEGRATION. • See 4.5 DPT INTEGRATION FEATURES AND SETUP PROCEDURES FOR THE PANASONIC KX-TA1232 AND KX-TD SERIES. • See 4.5.1 Live Call Screening (LCS) Programming. • See 4.5.2 Live Call Screening Password Assignment. • See 4.5.3 Live Call Screening Password Canceling. • See 4.5.4 Live Call Screening Recording Mode Assignment via System Programming. • See 4.5.5 Live Call Screening Private/Hands-Free Mode Assignment via Station Programming. • See 4.5.6 Live Call Screening Assignment via PC Programming. • See 4.5.7 Live Call Screening Button Assignment via Station Programming. • See 4.5.8 Live Call Screening Cancel Button Assignment via Station Programming. • See 4.5.13 Live Call Screening Activation. • See 4.5.14 Live Call Screening Password Control.

Table A-1

FEATURE	DESCRIPTION	REFERENCES
<p>Live Call Screening (DPT Integration Only)</p>	<p>permits the subscriber to monitor incoming calls as messages are being recorded. The subscriber has the option of answering calls while monitoring or allowing the message to be recorded without interruption. There are two modes in this feature: Hands-free and Private.</p> <p>Hands-free permits the subscriber to hear the caller through the telephone's speaker and answer the call by lifting the handset. The Private Mode alerts by tone and requires the telephone handset to be lifted before the message can be monitored. Two-way communication is established by pressing the feature button.</p>	<ul style="list-style-type: none"> • See 4.6 DPT INTEGRATION FEATURES AND SETUP PROCEDURES FOR THE PANASONIC KX-TDA/KX-TAW SERIES PBX. • See 4.6.1 Live Call Screening (LCS) Programming. • See 4.6.2 Live Call Screening Password Assignment. • See 4.6.3 Live Call Screening Password Canceling. • See 4.6.4 Live Call Screening Recording Mode Assignment. • See 4.6.5 Live Call Screening Private/Hands-Free Mode Assignment. • See 4.6.6 Live Call Screening Assignment via PC Programming. • See 4.6.7 Live Call Screening Button Assignment. • See 4.6.8 Two-Way Recording (TWR) Button Assignment. • See 4.6.13 Live Call Screening Activation. • See "Message Cancel for Live Call Screening" in Table B-7 in B3 SYSTEM ADMINISTRATION—SETTING COS (CLASS OF SERVICE) PARAMETERS. • See C3 SETTING COS (CLASS OF SERVICE) PARAMETERS. • See "Live Call Screening" in the Glossary. • See 4.13 Live Call Screening in the Subscriber's Guide.

Table A-1

FEATURE	DESCRIPTION	REFERENCES
Logical Extension (All Calls Transfer to Mailbox)	is an extension that always receives calls directly into its mailbox. This feature is used by subscribers that are often unavailable or that do not have a telephone.	<ul style="list-style-type: none"> • See "All Calls Transfer to Mailbox" in Table B-4 in B2 SYSTEM ADMINISTRATION—MAILBOXES. • See "Creating and Editing a Mailbox" in C2 SETTING UP MAILBOXES. • See "Logical Extension (All Calls Transfer to Mailbox)" in the Glossary.
Mailbox	is a place where all messages to a subscriber are stored. Several mailbox options exist: Subscriber Mailbox, Interview Mailbox, System Manager's Mailbox, and Message Manager's Mailbox (General Delivery Mailbox).	<ul style="list-style-type: none"> • See 5.5 SETTING MAILBOXES. • See 6.2 SETTING UP MAILBOXES. • See 7.3.1 Mailbox Assignments. • See 7.3.10 Mailbox Usage Report. • See 7.3.11 Mailbox Usage Statistics Clear. • See B2 SYSTEM ADMINISTRATION—MAILBOXES. • See C2 SETTING UP MAILBOXES. • See Section 1 1 Mailbox Setup in the Subscriber's Guide.
Message Delivery, Internal	allows the VPS to automatically deliver a single message to multiple mailboxes.	<ul style="list-style-type: none"> • See "Group Distribution List—Personal", "Group Distribution List—System" and "Message Delivery Status" in this Table.

Table A-1

FEATURE	DESCRIPTION	REFERENCES
<p>Message Delivery Status</p>	<p>allows a subscriber to check the status of messages that have been sent. The sending subscriber has the option of canceling any of the messages after checking their status. If a recorded message has not been received, the VPS will voice report the following: the message's destination mailbox number and its contents.</p> <p>Message delivery status information is automatically deleted after the message has been received by the subscriber, or when the subscriber cancels the delivery, or when a new message arrives after 84 delivery status messages have been stored in the subscriber's mailbox (the oldest status message is always deleted first).</p>	<ul style="list-style-type: none"> • See 3.2 Checking Mailbox Distribution in the Subscriber's Guide.
<p>Message Reception Mode</p>	<p>allows incoming calls to be received by either a subscriber's regular or interview mailbox. This mode is effective for: (1) Incomplete Call Handling Service (when the subscriber's line is busy, or he cannot take the call, or when he has enabled Call Blocking), and (2) when the transfer destination of calls is set to a Logical Extension.</p>	<ul style="list-style-type: none"> • See "Interview Service" and "Logical Extension (All Calls Transfer to Mailbox)" in this Table. • See "All Calls Transfer to Mailbox" in Table B-4" in B2 SYSTEM ADMINISTRATION—MAILBOXES. • See 4.4 Message Reception Mode in the Subscriber's Guide.
<p>Message Scan</p>	<p>permits the subscriber to scan the first 4 s of each message. The subscriber can replay the previous message, play the next message, or play the entire message.</p>	<ul style="list-style-type: none"> • See "Message Scanning with Information" in Table B-7" in B3 SYSTEM ADMINISTRATION—SETTING COS (CLASS OF SERVICE) PARAMETERS. • See C3 SETTING COS (CLASS OF SERVICE) PARAMETERS. • See "Scanning Messages" in the Glossary. • See 2.1 Receiving Messages in the Subscriber's Guide.

Table A-1

FEATURE	DESCRIPTION	REFERENCES
Message Transfer	<p>allows the subscriber to transfer messages to other mailboxes after playing. The subscriber can also add a personal comment at the beginning of the message to be transferred if desired.</p> <p>One or more individual mailboxes can be specified for message transfer. Messages can also be transferred using either the System or Personal Group Distribution Lists.</p>	<ul style="list-style-type: none"> • See "Transferring Messages" in D2 MANAGING THE GENERAL DELIVERY MAILBOX. • See "Message Transfer" in the Glossary. • See 2.3 Message Transfer in the Subscriber's Guide.
Message Waiting Notification—Device	<p>automatically notifies the subscriber/Message Manager of the reception of new message(s) by calling either a specified telephone or beeper number. The message will automatically play when the subscriber/Message Manager answers a call to the telephone. When a beeper is called, the subscriber/Message Manager must call the VPS and access the message from the mailbox. Notification can be scheduled either on or off for a maximum of 2 times during any 24 h period.</p> <p>The subscriber/Message Manager can program a maximum of 3 telephones or beepers in sequence. The VPS will recall the number or number sequence for a specified number of times until answered.</p> <p>Notification is terminated when the subscriber/Message Manager has received the message, when the last number has been called a specified number of times, or at the completion of the programmed time period.</p>	<ul style="list-style-type: none"> • See "Message Waiting Notification from an SLT" in 3.1.4 PBX Requirements for Integration. • See "Notification Setting" in B2 SYSTEM ADMINISTRATION—MAILBOXES. • See "Authorization for Message Notification" in Table B-7 and Table B-8 in B3 SYSTEM ADMINISTRATION—SETTING COS (CLASS OF SERVICE) PARAMETERS. • See "Other Parameters-Message Waiting Notification" in B6.8 Other Parameters. • See C3 SETTING COS (CLASS OF SERVICE) PARAMETERS. • See D3 SETTING UP MESSAGE WAITING NOTIFICATION. • See "Message Waiting Notification" in the Glossary. • See 4.8 Message Waiting Notification in the Subscriber's Guide.

Table A-1

FEATURE	DESCRIPTION	REFERENCES
<p>Message Waiting Notification—Lamp</p>	<p>automatically illuminates the message waiting lamp on the subscriber's or the Message Manager's telephone when there are unplayed messages waiting in the mailbox.</p> <p>Note</p> <p>The extension assigned for Operator 1 in the Day Mode is the Message Manager's telephone. However, its default extension number (0) cannot be used with this feature. When using this feature, you must assign the extension number that is included in the Extension Numbering Plan.</p>	<ul style="list-style-type: none"> • See "Message Waiting Notification from an SLT" in 3.1.4 PBX Requirements for Integration. • See 7.2.13 Message Waiting Lamp Retry Times (MWL). • See "MWL Notification for Unreceived Message" in Table B-7 and Table B-8 in B3 SYSTEM ADMINISTRATION—SETTING COS (CLASS OF SERVICE) PARAMETERS. • See "Other Parameters-Message Waiting Notification" in B6.8 Other Parameters. • See C3 SETTING COS (CLASS OF SERVICE) PARAMETERS. • See D3 SETTING UP MESSAGE WAITING NOTIFICATION. • See "Message Waiting Lamp" in the Glossary. • See 4.8 Message Waiting Notification in the Subscriber's Guide.
<p>Multilingual Service</p>	<p>permits up to 3 languages to be used for prompt options. If the "Selective" mode is selected, callers are able to choose their desired language.</p>	<ul style="list-style-type: none"> • See "Incoming Call Service Prompt" in Table 5-5 in 5.3.1 Port Service Menu. • See "System Prompt Selection Number", "User 1 Prompt Selection Number", and "User 2 Prompt Selection Number" in Table B-28 in B6.5 Prompt Setting. • See "Recording Menus and Voice Labels" and "Recording User Prompts" in D6 RECORDING MESSAGES. • See "Multilingual Selection Menu" in the Glossary.

Table A-1

FEATURE	DESCRIPTION	REFERENCES
No Answer Coverage Mode	<p>specifies how the calls will be handled when Operator 1, 2 and/or 3 do not answer them within the specified "Operator No Answer Time". There are 4 options:</p> <p>Caller Select^{*1}—caller may leave a message or call another extension.</p> <p>Leave Message^{*1}—caller may leave a message in Operators' mailbox.</p> <p>Disconnect Message^{*1}—caller is disconnected from the VPS after hearing "Thank you for calling."</p> <p>Next Operator^{*2}—caller is transferred to the next operator (Operator 2 or 3) extension.</p> <p>*1: Assignable for Operator 1, 2 and 3 *2: Assignable for Operator 1 and 2</p>	<ul style="list-style-type: none"> • See "No Answer Coverage Mode" in Table 5-6 in 5.4.3 Operator's Parameters. • See "No Answer Coverage Mode" in Table B-12, Table B-13 and Table B-14 in B5.1 Automated Attendant Parameters.
One-Touch Two-Way Transfer (DPT Integration only)	<p>Permits a subscriber to record two-way conversations into another person's mailbox with one-touch. Available only with KX-TDA/KX-TAW series.</p>	<ul style="list-style-type: none"> • See 4.1 GUIDELINES FOR DPT INTEGRATION. • See 4.6 DPT INTEGRATION FEATURES AND SETUP PROCEDURES FOR THE PANASONIC KX-TDA/KX-TAW SERIES PBX. • See 4.6.6 Live Call Screening Assignment via PC Programming. • See 4.6.10 One-Touch Two-Way Transfer (One-Touch TWT) Button Assignment. • See 4.6.12 Button Assignment via PC Programming. • See 4.6.16 One-Touch Two-Way Transfer (One-Touch TWT) into Mailbox. • See "One-Touch Two-Way Transfer (One-Touch TWT)" in the Glossary.
Operator Service	<p>permits callers to request a live operator by pressing [0] on the telephone keypad. Up to 3 operators can be specified to receive calls in the Day, Night, Lunch and Break Modes.</p>	<ul style="list-style-type: none"> • See 5.4.3 Operator's Parameters. • See "Operator's Parameters" in B5.1 Automated Attendant Parameters. • See "Operator's Extensions" in D4 CUSTOMIZING THE MESSAGE MANAGER'S MAILBOX.

Table A-1

FEATURE	DESCRIPTION	REFERENCES
Password Administration	allows the System Administrator or System Manager to clear a subscriber password (so that a new one can be assigned).	<ul style="list-style-type: none"> • See 5.5.4 Password Reset. • See "Resetting a Mailbox Password" in C2 SETTING UP MAILBOXES.
PBX Integration	allows the VPS and PBX to work together as an integrated unit. Two integration options are available: Inband Integration and DPT Integration.	<ul style="list-style-type: none"> • See 2.7 CONNECTIONS. • See Section 3 INTEGRATING THE VPS WITH PANASONIC KX-T PHONE SYSTEMS. • See Section 4 INTEGRATING THE VPS WITH THE PANASONIC KX-T DIGITAL PBX.
Personal Custom Service	<p>allows a subscriber to set the following Custom Services in his personal greeting (Personal Custom Service):</p> <ul style="list-style-type: none"> • Transfer to Mailbox • Transfer to Extension • Transfer to Outside • Custom Service • VM Service (Voice Mail Service) • AA Service (Call Transfer Service) <p>A caller can select a desired service from those above while listening to the personal greeting or recording a message.</p> <p>You can also choose what happens if a caller does not dial anything after your personal greeting (No DTMF Input Operation) as follows:</p> <ul style="list-style-type: none"> • Message Recording—He will be guided to leave a message. • Disconnect—The line will be disconnected. 	<ul style="list-style-type: none"> • See "Personal Custom Service" in the Glossary. • See 4.19 Setting Personal Custom Service in the Subscriber's Guide.

Table A-1

FEATURE	DESCRIPTION	REFERENCES
<p>Personal Greeting for Caller ID (DPT Integration Only)</p>	<p>permits subscribers to record up to 4 personal greetings for calls from pre-assigned Caller ID numbers. Each greeting supports up to 8 caller ID numbers. This feature can be enabled or disabled in the COS (Class of Service) settings.</p>	<ul style="list-style-type: none"> • See 4.1 GUIDELINES FOR DPT INTEGRATION. • See "Personal Greeting for CID" in Table B-7 in B3 SYSTEM ADMINISTRATION—SETTING COS (CLASS OF SERVICE) PARAMETERS. • See C3 SETTING COS (CLASS OF SERVICE) PARAMETERS. • See "Personal Greeting for Caller ID" in the Glossary. • See 4.10 Recording Personal Greetings for Caller ID in the Subscriber's Guide. • See 4.11 Assigning Caller ID Numbers for Personal Greeting for Caller ID in the Subscriber's Guide.
<p>Personal Greetings</p>	<p>permit the subscriber to record the following 3 personal message greetings:</p> <p>No Answer—Plays when unavailable to answer the call during business hours.</p> <p>Busy Signal—Plays whenever the line is busy.</p> <p>After Hours—Plays when the VPS is in the Night Mode.</p> <p>The No Answer Greeting will also play:</p> <ul style="list-style-type: none"> • when the caller accesses the mailbox directly. • when the Busy Signal or the After Hours Greeting has not been recorded. 	<ul style="list-style-type: none"> • See 6.2 SETTING UP MAILBOXES. • See C3 SETTING COS (CLASS OF SERVICE) PARAMETERS. • See "Personal Greetings" in the Glossary. • See 1.3 Changing and Erasing Personal Greetings in the Subscriber's Guide.
<p>Play System Prompt After Personal Greeting</p>	<p>allows the "Guidance for Recording" message to be played for the caller after the "Personal Greeting". The "Guidance for Recording" message instructs the caller how to terminate the call, access more features, and rerecord the message.</p>	<ul style="list-style-type: none"> • See "Play System Prompt after Personal Greeting" in Table B-7 in B3 SYSTEM ADMINISTRATION—SETTING COS (CLASS OF SERVICE) PARAMETERS. • See C3 SETTING COS (CLASS OF SERVICE) PARAMETERS.

Table A-1

FEATURE	DESCRIPTION	REFERENCES
<p>Port Service</p>	<p>allows assignment of call services to each port.</p> <p>The incoming call service determines which service is used when answering incoming calls. These services include: Voice Mail Service, Automated Attendant Service, Interview Service and Custom Service.</p> <p>Note</p> <p>The System Manager can change the Company Greeting setting remotely by simply calling the VPS (see C6 CHANGING THE COMPANY GREETING AND INCOMING CALL SERVICE SETTING).</p>	<ul style="list-style-type: none"> • See 5.2 PORT SETTING OPTIONS. • See B4 SYSTEM ADMINISTRATION—PORT/TRUNK SERVICE.
<p>Private Message</p>	<p>allows a subscriber and the System Manager to specify a message as "Private" when sending it to other subscribers, the Message Manager and/or the System Manager. A message specified as "Private" cannot be transferred. It is also possible to specify messages recorded in the Voice Mail Service as "Private".</p>	<ul style="list-style-type: none"> • See "Delivering Messages to Specified Mailboxes" in C9 DELIVERING MESSAGES. • See "Private Message" in the Glossary. • See 3.1 Delivering Messages to Other Subscribers in the Subscriber's Guide.
<p>Receive Message</p>	<p>allows subscribers to access messages left in their mailboxes. Three options are available to subscribers:</p> <p>Reply to Message Sender—permits subscribers to reply to the message sender without specifying the extension.</p> <p>Message Transfer—permits subscribers to transfer their messages to other mailboxes.</p> <p>Message Scan—permits subscribers to listen to the first 4 s of each message.</p>	<ul style="list-style-type: none"> • See "Message Transfer" and "Message Scan" in this Table. • See 2.1 Receiving Messages in the Subscriber's Guide. • See 2.2 Replying to Messages in the Subscriber's Guide.

Table A-1

FEATURE	DESCRIPTION	REFERENCES
<p>Remote Call Forwarding Set (DPT Integration only)</p>	<p>allows a subscriber and the Message Manager to program his extension from a remote location to forward various types of calls to a desired extension or an outside telephone.</p> <p>There are 6 forwarding settings available: FWD All—Forward all incoming calls to a desired extension number. FWD Busy—Forward all incoming calls to a desired extension number when the line is busy. FWD No Answer—Forward all incoming calls to a desired extension number when there is no answer. FWD Busy or No Answer—Forward all incoming calls to a desired extension number when the line is busy or there is no answer. FWD to CO*—Forward all incoming calls to the Telephone number 1 or 2 (programmed in the Mailbox Setting), or to any other number. FWD Cancel—Cancel the forwarding setting.</p> <p>* Must be enabled in the COS (Class of Service) settings to be utilized.</p> <p>With respect to PBX programming, it is possible that "Call Forward to CO" is disabled. To enable VPS Remote Call Forwarding, the KX-TD1232, for example, must be programmed properly. For the COS of the extensions whose calls are to be forwarded to a CO line, enable the following: [504] Call Forward to Outside Line.</p> <p>Note</p> <p>The extension assigned for Operator 1 in the Day Mode is the Message Manager's extension. However, its default extension number (0) cannot be used with this feature. When using this feature, you must assign the extension number that is included in the Extension Numbering Plan.</p>	<ul style="list-style-type: none"> • See 5.5.2 Entering a Mailbox. • See "Remote Call Forward to CO" in B2 SYSTEM ADMINISTRATION—MAILBOXES. • See "Remote Call FWD to CO" in Table B-7 and Table B-8 in B3 SYSTEM ADMINISTRATION—SETTING COS (CLASS OF SERVICE) PARAMETERS. • See C3 SETTING COS (CLASS OF SERVICE) PARAMETERS. • See D7 REMOTE CALL FORWARDING SET. • See "Remote Call Forwarding Set" in the Glossary. • See 4.16 Remote Call Forwarding Set in the Subscriber's Guide.
<p>Rotary Telephone Service</p>	<p>provides guidance to callers using rotary telephone systems or when several seconds pass without anything being entered by the caller.</p>	<ul style="list-style-type: none"> • See "Other Parameters-Rotary Telephone Service" in B6.8 Other Parameters. • See "Rotary Telephone" in the Glossary.

Table A-1

FEATURE	DESCRIPTION	REFERENCES
<p>Service Access Commands</p>	<p>allow the caller to directly access several standard features.</p> <p><i>(0) to repeat the Help Menu or call the operator</i></p> <p><i>(*) to return to previous menu</i></p> <p><i>(#) (1) to dial by name</i></p> <p><i>(#) (2) Custom Service Menu</i></p> <p><i>(#) (3) Department Dialing</i></p> <p><i>(#) (5) Login</i></p> <p><i>(#) (6) Voice Mail Service</i></p> <p><i>(#) (7) to restart (Subscriber's main menu)</i></p> <p><i>(#) (8) to call transfer</i></p> <p><i>(#) (9) to exit</i></p>	<ul style="list-style-type: none"> • See 5.2.6 Voice Mail. • See 5.2.10 Automated Attendant. • See 1.6 Service Access Commands in the Subscriber's Guide.
<p>Service Mode</p>	<p>allows the System Administrator or the System Manager to change the call handling method that is programmed for each Time Group 1-8.</p> <p>Once the Service Mode has been changed, it is retained unless the System Manager or System Administrator changes it again, even after the power turns off.</p> <p>There are 6 Service Modes available:</p> <p>Automatic Mode—Operates according to the setting in Time Service.</p> <p>Manual Day Mode—Operates only in Day Mode.</p> <p>Manual Night Mode—Operates only in Night Mode.</p> <p>Manual Lunch Mode—Operates only in Lunch Mode.</p> <p>Manual Break Mode—Operates only in Break Mode.</p> <p>PBX Control Mode—Operation changes depending on PBX time period (DPT Integration only).</p>	<ul style="list-style-type: none"> • See "Time Group" and "Time Service" in this Table. • See "Time Group Service-Service Mode" in B6.2 Time Group Service. • See C5 CHANGING THE SERVICE MODE SETTING.

Table A-1

FEATURE	DESCRIPTION	REFERENCES
Special Feature Authorization	<p>permits mailbox owners to use the following special features: Remote Call Forward to CO, Delete Message Confirmation, Message Waiting Notification, External Message Delivery, and Auto Forwarding.</p> <p>But the Message Manager can only utilize the following features: Remote Call Forward to CO, Delete Message Confirmation, and Message Waiting Notification; and the System Manager can only utilize the Delete Message Confirmation feature.</p>	<ul style="list-style-type: none"> • See "Remote Call FWD to CO", "Delete Message Confirmation", "Authorization for Message Notification", "Authorization for External Message Delivery", and "Authorization for Auto Forwarding" in Table B-7 in B3 SYSTEM ADMINISTRATION—SETTING COS (CLASS OF SERVICE) PARAMETERS. • See "Remote Call FWD to CO", "Delete Message Confirmation", and "Authorization for Message Notification" in Table B-8 in B3 SYSTEM ADMINISTRATION—SETTING COS (CLASS OF SERVICE) PARAMETERS. • See C3 SETTING COS (CLASS OF SERVICE) PARAMETERS.
Subscriber Tutorial	<p>guides a subscriber who accesses his mailbox for the first time to set up these items simply by following Help messages:</p> <ul style="list-style-type: none"> • Password • Owner's Name • Personal Greetings (No Answer Greeting/Busy Greeting/After Hours Greeting) 	<ul style="list-style-type: none"> • See 6.2.1 Subscriber Tutorial. • See "Subscriber Tutorial" in Table B-7 in B3 SYSTEM ADMINISTRATION—SETTING COS (CLASS OF SERVICE) PARAMETERS. • See C3 SETTING COS (CLASS OF SERVICE) PARAMETERS. • See "DID Call Routing" in the Glossary. • See 1.2 Subscriber Tutorial in the Subscriber's Guide.
System Clock	<p>allows the correct setting of the date and time to be made for proper VPS operation.</p>	<ul style="list-style-type: none"> • See 7.2.4 Set Time (TIME). • See C4 SETTING THE SYSTEM CLOCK. • See D5 SETTING THE SYSTEM CLOCK.

Table A-1

FEATURE	DESCRIPTION	REFERENCES
System Reports	Eight System Reports are available to the System Administrator and System Manager to monitor VPS operating status. These reports include: Mailbox Assignments, COS Assignments, System Service Report, Call Account Report, Port Usage Report, Disk Usage Report, Mailbox Usage Report, and the Fax Call Report.	<ul style="list-style-type: none"> • See 7.3 SYSTEM REPORTS. • See C8 CHECKING SYSTEM USAGE (SYSTEM REPORTS). • See "System Report" in the Glossary.
System Security	By default, the System/Message Managers cannot access the VPS from their telephones until the System Administrator enables the relevant settings and sets a password for access. The System/Message Managers always need to enter this password to access the VPS. The System Administrator can also choose to set a default password for subscribers' mailboxes. If this setting is enabled, a default password is automatically assigned when mailboxes are created.	<ul style="list-style-type: none"> • See B6.7 System Security.
Time Group	is a time frame in which Day, Night, Lunch and Break time periods can be programmed. It is possible to assign up to 8 different Time Groups. It is necessary to assign a specific Time Group for use in both Port and Trunk Services (in the Day Mode setting menu).	<ul style="list-style-type: none"> • See "Service Mode" and "Time Service" in this table. • See "Time Group No." in Table B-9 in B4.1 Port Assignment, and Table B-10 in B4.2 Trunk Group Assignment. • See B6.2 Time Group Service. • See C5 CHANGING THE SERVICE MODE SETTING.
Time Service	is a timer function that initiates the appropriate call handling method depending on the time of day: Day, Night, Lunch, and Break Service periods. Each Time Group (1-8) can have different Time Service setting.	<ul style="list-style-type: none"> • See "Service Mode" in this table. • See "Time Service (1-5-2-2)" in 5.2.2 Custom Service Features. • See "Time Group Service-Time Service" in B6.2 Time Group Service.
Time Synchronization (DPT Integration only)	occurs between the VPS and PBX when the PBX sets a new date and time, or when DPT Integration is established. The date and time are automatically sent from the PBX to the VPS.	<ul style="list-style-type: none"> • See 4.1 GUIDELINES FOR DPT INTEGRATION. • See 7.2.4 Set Time (TIME). • See "Time Synchronization" in the Glossary.

Table A-1

FEATURE	DESCRIPTION	REFERENCES
<p>Toll Saver (DPT Integration only)</p>	<p>permits a subscriber to check his mailbox from pre-assigned Caller ID numbers or by dialing a pre-assigned DID number without telephone charges.</p> <p>Note</p> <p>DID number setting for this feature is only available when the VPS is connected to the following PBXs with DPT Integration.</p> <ul style="list-style-type: none"> • KX-TD816 (P311Q or higher) • KX-TD1232 (P211Q or higher) • KX-TD500 (V4M or higher) 	<ul style="list-style-type: none"> • See "Caller ID Number 1 for Toll Saver", "Caller ID Number 2 for Toll Saver", and "DID Number for Toll Saver" in Table 5-7 in 5.5 SETTING MAILBOXES. • See "Toll Saver" in Table B-7 in B3 SYSTEM ADMINISTRATION—SETTING COS (CLASS OF SERVICE) PARAMETERS. • See B5.4 Toll Saver. • See C3 SETTING COS (CLASS OF SERVICE) PARAMETERS. • See "Toll Saver" in the Glossary. • See 4.18 Setting Telephone Numbers for Toll Saver in the Subscriber's Guide.
<p>Trunk Service (Universal Port) (DPT Integration only)</p>	<p>allows call services to be assigned to each trunk (CO line) group.</p> <p>The incoming call service determines which service is used when answering incoming calls. These services include: Voice Mail Service, Automated Attendant Service, Interview Service and Custom Service.</p> <p>Note</p> <p>The System Manager can change the Company Greeting setting remotely by simply calling the VPS (see C6 CHANGING THE COMPANY GREETING AND INCOMING CALL SERVICE SETTING).</p>	<ul style="list-style-type: none"> • See 4.1 GUIDELINES FOR DPT INTEGRATION. • See B4 SYSTEM ADMINISTRATION—PORT/TRUNK SERVICE.

Table A-1

FEATURE	DESCRIPTION	REFERENCES
<p>Two-Way Recording (DPT Integration only)</p>	<p>permits a subscriber to record two-way conversations into his mailbox.</p>	<ul style="list-style-type: none"> • See 4.1 GUIDELINES FOR DPT INTEGRATION. • See 4.5.9 Two-Way Recording Button Assignment via Station Programming. • See 4.5.12 Button Assignment via PC Programming. • See 4.5.15 Two-Way Recording into Mailbox. • See 4.5.17 A Restriction on TWR/TWT Activation. • See 4.6.8 Two-Way Recording (TWR) Button Assignment. • See 4.6.12 Button Assignment via PC Programming. • See 4.6.14 Two-Way Recording (TWR) into Mailbox. • See "Two-Way Recording" in the Glossary. • See 4.14 Recording a Two-Way Conversation in the Subscriber's Guide.
<p>Two-Way Transfer (DPT Integration only)</p>	<p>permits a subscriber to record two-way conversations into another person's mailbox.</p>	<ul style="list-style-type: none"> • See 4.1 GUIDELINES FOR DPT INTEGRATION. • See 4.5.10 Two-Way Transfer Button Assignment via Station Programming. • See 4.5.12 Button Assignment via PC Programming. • See 4.5.16 Two-Way Transfer into Mailbox. • See 4.5.17 A Restriction on TWR/TWT Activation. • See 4.6.9 Two-Way Transfer (TWT) Button Assignment. • See 4.6.12 Button Assignment via PC Programming. • See 4.6.15 Two-Way Transfer (TWT) into Mailbox. • See "Two-Way Transfer" in the Glossary. • See 4.14 Recording a Two-Way Conversation in the Subscriber's Guide.

Table A-1

FEATURE	DESCRIPTION	REFERENCES
Unlimited Message Length	permits a mailbox owner to record two-way conversations of unlimited length into his or another person's mailbox (Two-Way Recording or Two-Way Transfer). The maximum recording time for other messages will automatically be set to 6 min. To allow unlimited recording time, the "Message Length" parameter must be set to "0: Unlimited" in the COS (Class of Service) settings.	<ul style="list-style-type: none"> • See "Two-Way Recording" and "Two-Way Transfer" in this table. • See "Message Length" in Table B-7 and Table B-8 in B3 SYSTEM ADMINISTRATION—SETTING COS (CLASS OF SERVICE) PARAMETERS. • See C3 SETTING COS (CLASS OF SERVICE) PARAMETERS. • See "Unlimited Message Length" in the Glossary.
Utility Commands	allow the System Administrator to access critical VPS functions.	<ul style="list-style-type: none"> • See 7.2 UTILITY COMMANDS.
Voice Mail Service	permits a caller/non-subscriber to leave a message in any mailbox.	<ul style="list-style-type: none"> • See 5.2.6 Voice Mail. • See B4 SYSTEM ADMINISTRATION—PORT/TRUNK SERVICE. • See "Voice Mail" in the Glossary.
Voice Prompts	<p>are announcements that instruct the caller.</p> <p>There are 3 kinds of voice prompts:</p> <p>(1) System Prompts (recorded at the factory in English),</p> <p>(2) User 1 Prompts (not recorded), and</p> <p>(3) User 2 Prompts (recorded at the factory in Spanish).</p>	<ul style="list-style-type: none"> • See 6.1.5 Customizing User Prompts (Enter #6*9998,5,6). • See "Prompt Mode" in Table B-7 and Table B-8 in B3 SYSTEM ADMINISTRATION—SETTING COS (CLASS OF SERVICE) PARAMETERS. • See B6.5 Prompt Setting. • See C3 SETTING COS (CLASS OF SERVICE) PARAMETERS. • See "Recording User Prompts" in D6 RECORDING MESSAGES. • See "Voice Prompt" in the Glossary.

Appendix B
SYSTEM ADMINISTRATOR'S GUIDE

B1 SYSTEM NAVIGATION

Use either a VT100 or compatible terminal or other RS-232C terminals (ASCII Terminals) to perform System Administration, which includes the setting and changing of system parameters. This can be a personal computer with emulation software.

Keyboard Use

VT100 or Compatible Terminals

When using a VT100 or compatible terminal, perform either of the following steps to choose options from screen menus:

- Move the cursor to the desired listed option and **Press RETURN**.
- **Type** the number of the option desired and **Press RETURN**.

Table B-1

KEY	FUNCTIONS
↑	Moves the cursor up one line.
↓	Moves the cursor down one line.
→	Moves the cursor to the right.
←	Moves the cursor to the left.
(1)-(9)	Typing any number 1 through 9 will select the corresponding option for that number.
(RETURN)	Also the ENTER key. Selects the number entered.
(\)	Exits the current screen and returns to the previous step within the menu.
(Back space)	Used to correct any mis-typed entry.

Other RS-232C Terminals (ASCII Terminals)

When using RS-232C Terminals, **Type** the number of the option desired and **Press RETURN** to choose menu options.

Table B-2

KEY	FUNCTIONS
(1)-(9), then (RETURN)	Typing any number 1 through 9 will select the corresponding option for that number. Pressing RETURN will select the number entered.
(\)	Exits the current screen and returns to the previous step within the menu.

Using the Interface

Programming Guidance

Each parameter is accessed through a series of menu screens. The Programming Menu Structure Diagram provided below depicts this menu flow. A menu flow that corresponds to the Programming Menu Structure Diagram is given at the beginning of each section. This flow is designed to guide the user through the appropriate menus to the parameter to be setup or changed. The following example illustrates how the menu flow is used.

Example:

System Administration Top Menu - 1 - 4 - 1 - 1

1. **Press 1** at the System Administration Top Menu. **Press RETURN.**
2. **Press 4** at the Program Menu. **Press RETURN.**
3. **Press 1** at the Service Setting Menu. **Press RETURN.**
4. **Press 1** on the Automated Attendant Menu to select "1. Department Dialing," when selected.
5. **Press RETURN.** Auto. Attn-Department Dialing Menu will be displayed on the terminal.

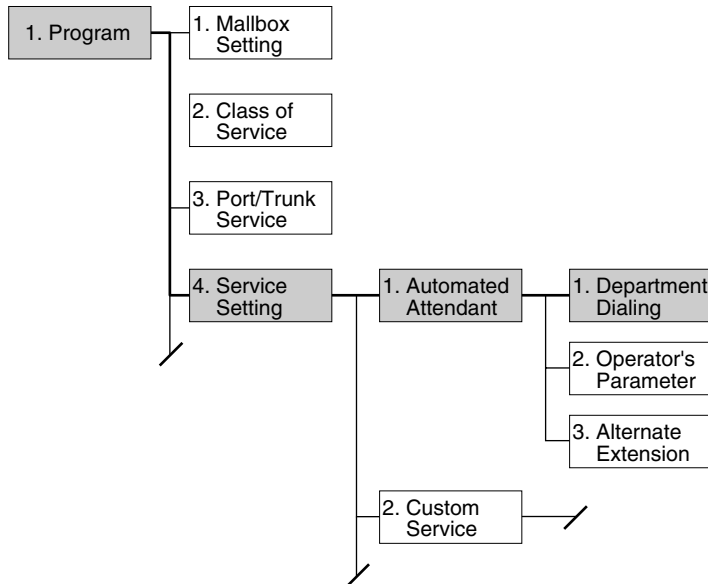

Programming Menu Structure Diagram

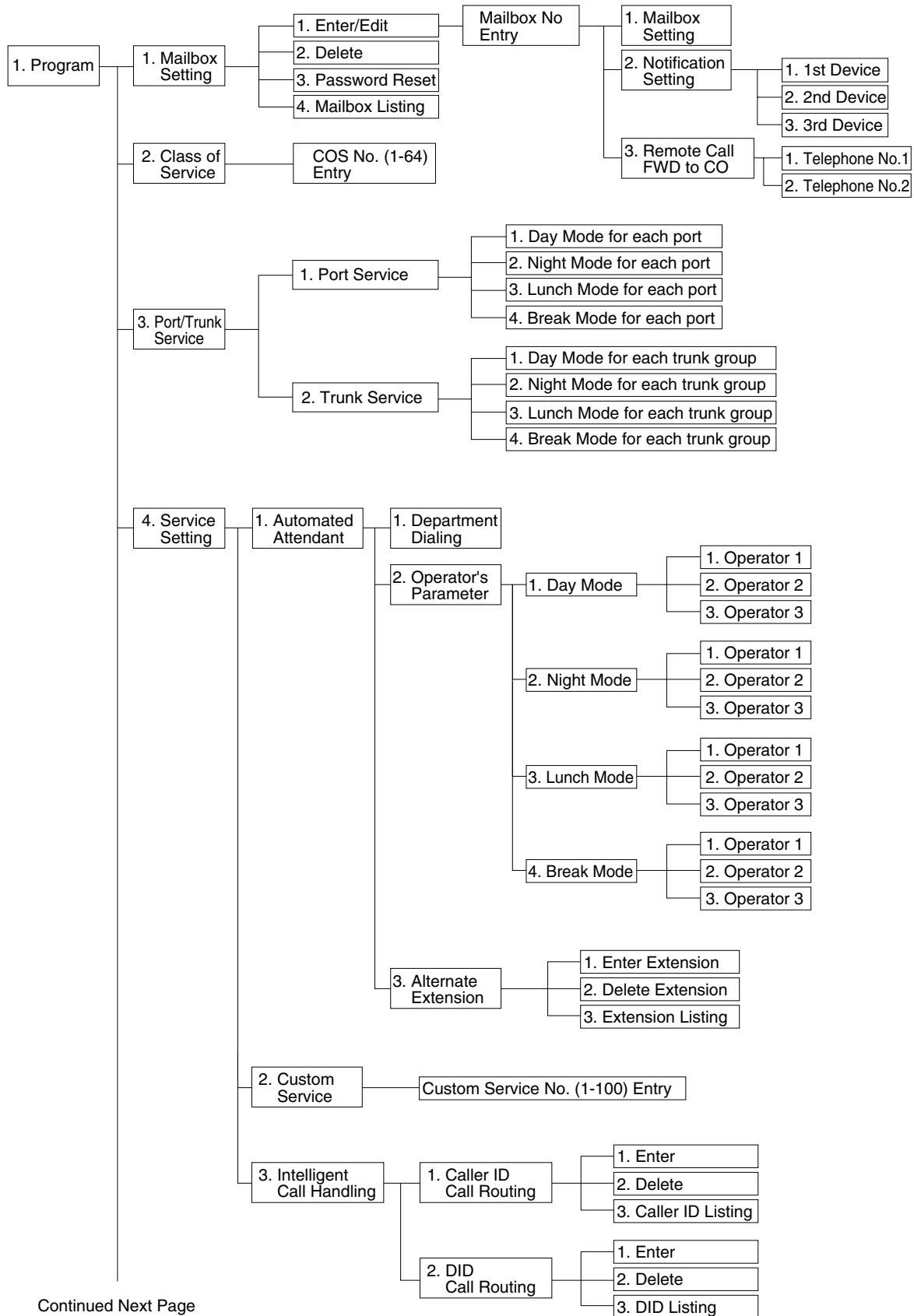

Continued Next Page

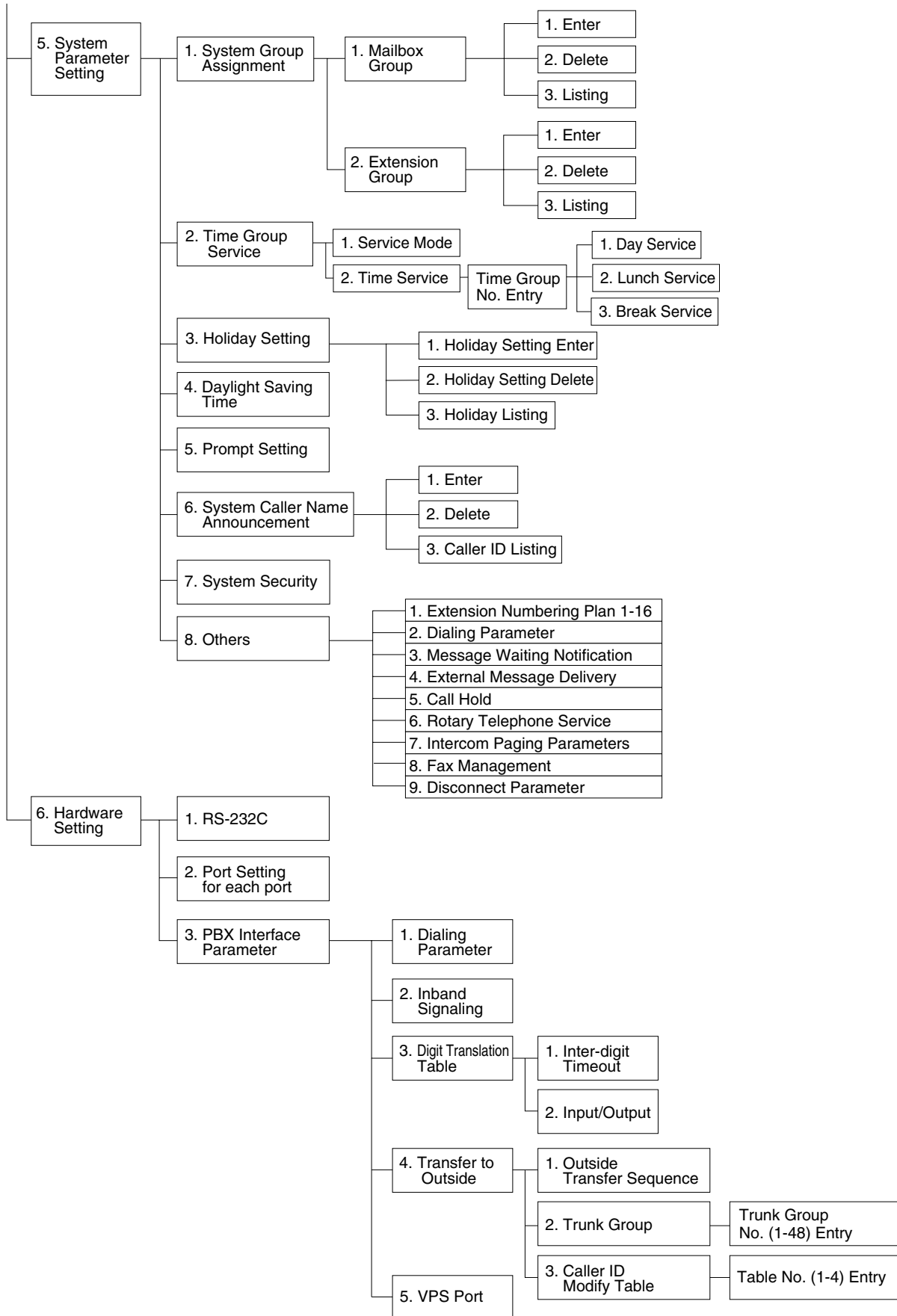

B2 SYSTEM ADMINISTRATION—MAILBOXES

Up to 62 (KX-TVS125) or 1022 (KX-TVS225/KX-TVS325) subscriber Mailboxes can be created or edited by following the correct sequence of steps.

To access the menu for mailbox setup, follow the menu path as shown:

System Administration Top Menu-1-1-1-Mailbox No.

Table B-3

Parameter	Value Range (Default)	Description/Function
Mailbox Number	2-5 digits (None)	Specifies the subscriber's mailbox number. Mailbox number length is determined during setup or when initializing the system. Mailbox numbers cannot begin with "0". If the length of the mailbox number has been defined as 4 digits, for example, the valid range for all mailbox numbers would be 1000 through 9997 (9998 and 9999 would be reserved for the Message Manager and the System Manager). The length of the mailbox number cannot be changed through the Mailbox Setting screen once it has been specified.

Editing Mailboxes

The parameters of each mailbox can be edited based upon the needs of the subscriber.

To access the menu for mailbox editing, follow the menu path as shown:

System Administration Top Menu-1-1-1-Mailbox No.-1

Table B-4

Parameter	Value Range (Default)	Description/Function
The Extension of the Owner	2-5 digits (None)	Used to transfer calls through the VPS to a subscriber's mailbox. Any valid extension number including an Extension Group List number can be assigned. Note If an Extension Group List number is assigned to a mailbox, all group members are able to share the information stored there.

Table B-4

Parameter	Value Range (Default)	Description/Function
Owner First Name	Up to 16 alphabetic characters	The first 4 letters of both the first and last name is printed on the Mailbox Assignments report.
Owner Last Name	(None)	The Dialing by Name feature uses the last name.
Class of Service No.	COS No.1-62 (1)	Used to define the set of services available to the subscriber. Notes <ul style="list-style-type: none"> We recommend that parameters for each COS number be defined before assigning a Class of Service (COS) number. COS No.63 pertains to the Message Manager while COS No.64 pertains to the System Manager. These numbers cannot be entered in the COS No. data field.
Covering Extension	2-5 digits (None)	Identifies the extension number that will receive unanswered subscriber calls. The Automated Attendant Service accomplishes this call transfer. The caller is given the option of transferring the call or leaving a message in the subscriber's mailbox. The Covering Extension is one of the Incomplete Call Handling Service options that can be enabled or disabled by the subscriber using the telephone keypad. Note The Extension Group List or Logical Extension Numbers cannot be assigned as covering extensions.
Interview Mailbox Number	2-5 digits (None)	Permits a mailbox owner to own an interview mailbox. The interview mailbox number must be an unassigned mailbox number. Note The replies to an interview session constitute one message. If the subscriber expects many interview messages, "Mailbox Capacity Maximum Messages" (see Table B-7 in B3 SYSTEM ADMINISTRATION—SETTING COS (CLASS OF SERVICE) PARAMETERS) should be raised to a higher value. Possibly, the subscriber should be assigned to a different COS.

Table B-4

Parameter	Value Range (Default)	Description/Function
All Calls Transfer to Mailbox	1. Yes 2. No (No)	<p>If this parameter is set to "Yes", all calls routed to the extension are automatically forwarded to the extension's mailbox without ringing the telephone. Forwarding is accomplished through the Automated Attendant service. Callers are permitted to leave a message.</p> <p>Note</p> <p>When this feature has been set to "Yes", the mailbox owner's extension does not necessarily need to exist as a phone extension of the PBX.</p>
Caller ID Number 1 for Toll Saver	Up to 20 digits consisting of 1-9, 0, * (None)	<p>Specifies up to two Caller ID numbers or a DID number for Toll Saver. The subscriber can check whether there are new messages in his mailbox with these phone numbers without incurring telephone charges. Note that when these phone numbers are specified by the subscriber, the phone numbers are unavailable to other subscribers in the system. (The phone numbers must be unique.)</p> <p>Notes</p> <ul style="list-style-type: none"> If Toll Saver is set to "Caller ID" in your Class of Service, a DID number for Toll Saver cannot be assigned. If Toll Saver is set to "DID number" in your Class of Service, Caller ID Number 1/2 for Toll Saver cannot be assigned. If Toll Saver is set to "No" in your Class of Service, neither Caller ID Numbers nor a DID number can be assigned. DID number setting for this feature is only available when the VPS is connected to the following PBXs with DPT Integration. <ul style="list-style-type: none"> KX-TD816 (P311Q or higher) KX-TD1232 (P211Q or higher) KX-TD500 (V4M or higher)
Caller ID Number 2 for Toll Saver		
DID Number for Toll Saver		

Table B-4

Parameter	Value Range (Default)	Description/Function
Extension Transfer Sequence	Up to 12 digits consisting of 1-9, 0, *, #, Y, D, F, R, T, S, W, X, A (Y:System)	Specifies how the VPS transfers a call to an extension for each mailbox (Personal Transfer Sequence). 1-9, 0, *, #: DIAL CODE Y: System D: Disconnect F: Flash R: Ring T: Tone S: Silence W: Transf.Wait X: Extn A: Answer Notes <ul style="list-style-type: none"> When "System" is selected, the VPS follows the "Extension Transfer Sequence" pre-assigned for the system in the "Program - Hardware - PBX Interface - Dialing Parameters Menu". "System" cannot be used with other sequence codes. This sequence has higher priority than "Alternate Transfer Sequence".
Call Transfer No Answer Time	10-60s, S: System (System)	Specifies the length of time that the VPS must wait before retrieving the transferred call when there is no answer at the destination extension. This can be set for each mailbox. Note When "System" is selected, the VPS follows the "Call Transfer No Answer Time" pre-assigned for the system in the "Program - System Parameter - Others - Dialing Parameters Menu".

Notification Setting

Follow the procedure below to set the parameters for the Message Waiting Notification Device feature. A maximum of 3 destinations (Device 1, 2, 3) can be specified per mailbox.

- *Class of Service programming determines if the subscriber is able to use this feature.*
- *If the destination device is a telephone, the subscriber will be called when he has message(s), and will have a chance to listen to the message(s).*
- *If the destination device is a beeper, the subscriber will be notified when he has message(s). If the beeper has a display, it is possible to send to it a callback number. The caller can enter the callback number when he leaves a message. If he does not*

enter a callback number, either the System Callback No., or the caller's number if it is received through a telephone company's Caller ID service, will be sent instead.

To access the menu for Message Waiting Notification, follow the menu path as shown:

System Administration Top Menu-1-1-1-Mailbox No.-2-Device No. 1, 2, or 3.

Notification Setting-Device 1, 2, or 3

Table B-5

Parameter	Value Range (Default)	Description/Function
Dial Number	Up to 32 digits consisting of 1-9, 0, *, # P, T, M, X (None)	<p>Assigns a telephone or beeper number to Device 1, 2, or 3. The subscriber can also specify the dial number from his telephone.</p> <p>P: Pause T: Dial Tone Detection M: Dial Mode Switching Code (Touchtone to Pulse, or Pulse to Touchtone) X: Callback Number Entry Code</p> <p>1-9, 0, *, #: Dial Codes</p> <p>Note</p> <p>The callback number entry code "X" must be included in the number to be called if the Beeper Callback No. Entry Mode is enabled through COS and "Type of Device" is set to "Beeper". The proper number of "Pauses" must be inserted before the callback entry code.</p> <p>Notice</p> <p>When the VPS calls to a CO line via a PRI (ISDN Primary Rate Access Interface) card of a Panasonic PBX, please be sure to add "#" after the telephone number (1112223333 in the example here): <i>Example: 9P1112223333#PP123PP456PPX#</i> Please contact your System Administrator for more explanation.</p>
Type of Device	1. Telephone 2. Beeper (Telephone)	Specifies the device to receive notification. This is automatically set to "Beeper" when "X" is used in the Dial Number (above). The subscriber can also specify the type of device from his telephone.

Table B-5

Parameter	Value Range (Default)	Description/Function
Use Mode	1. Not Use 2. Continuously 3. Scheduled (Continuously)	Specifies how Device 1, 2, or 3 is to be used. The subscriber can also specify the use mode from his telephone. 1. Not Use—Device 1, 2, or 3 is not used for a notification call. 2. Continuously—Device 1, 2, or 3 is called whenever a message is recorded in the mailbox. 3. Scheduled—Device 1, 2, or 3 is called on a schedule basis when a message has been left in the mailbox.
No. of Retries	0-9 times (0)	Specifies the number of times that a notification call to Device 1, 2, or 3 should be attempted after a busy or no answer condition is received.
Busy Delay Time	0-120 min (3)	Specifies the time (in minutes) the VPS must wait after a busy condition is received before making another notification call to Device 1, 2, or 3.
No Answer Delay Time	60-120 min (60)	Specifies the time (in minutes) the VPS must wait after a no-answer condition is received before making another notification call to Device 1, 2, or 3.
Time Frame 1, 2 MON: TUE: WED: THU: FRI: SAT: SUN:	1-12: h 00-59: min AM/PM: a.m./p.m. ×: All Day Space: No Use (No Use)	Specifies the daily schedule for the Message Waiting Notification service for 1 week for this device. Note These parameters are active only when "Use Mode" is set to "Scheduled".

Remote Call Forward to CO

Follow the procedure below to specify the destination outside telephone number(s) to which the callers are forwarded when the Remote Call Forwarding feature is set to an outside (CO) line.

Telephone number 1 and Telephone number 2 can be specified per mailbox.

- *Class of Service programming determines if the mailbox owner is able to use this feature.*
- *This feature is only available with DPT Integration.*

To access the menu for Remote Forward to CO, follow the menu path as shown:

System Administration Top Menu-1-1-1-Mailbox No.-3-Telephone Number 1 or 2.

Table B-6

Parameter	Value Range (Default)	Description/Function
Telephone Number 1, 2	Up to 24 digits (With the KX-TD500) or Up to 16 digits (With other KX-T series PBXs) (None)	Specifies the telephone number to which the callers are forwarded when Remote Call Forwarding is set to a CO line. The telephone number can contain the digits "0-9" and "*". The telephone number should begin with a Line Access Code (to seize a CO line). Note Pressing [(back space)] will clear the parameter.

Deleting a Mailbox

When a mailbox is deleted, the Voice Processing System erases all messages in the mailbox, removes the mailbox from all group distribution lists, deletes the personal group distribution lists assigned to the mailbox, erases the subscriber's name, and cancels all external delivery messages.

To access the menu for Deleting a Mailbox, follow the menu path as shown:

System Administration Top Menu-1-1-2-Mailbox No.

Resetting a Mailbox Password

Follow the procedure below to set the parameters for clearing a mailbox password.

To access the menu for clearing a mailbox password, follow the menu path as shown:

System Administration Top Menu-1-1-3-Mailbox No.

Listing Mailboxes

Follow the procedure below to display the mailbox number list.

To display the list of all mailbox numbers, follow the menu path as shown:

System Administration Top Menu-1-1-4

B3 SYSTEM ADMINISTRATION—SETTING COS (CLASS OF SERVICE) PARAMETERS

The COS-Class of Service parameters define the set of services that are available to mailbox owners. A maximum of 64 (1-64) classes can be specified. A class of service number can be assigned for each mailbox. More than 1 subscriber can share the same class of service.

- *COS number 63 is only available to the Message Manager while COS number 64 is only available to the System Manager.*
- *The procedure below determines the utilization of the following special features on a COS basis:*
 - *Remote Call Forward to CO (available for COS numbers 1-63)*
 - *Delete Message Confirmation (available for COS numbers 1-64)*
 - *Message Waiting Notification (available for COS numbers 1-63)*
 - *External Message Delivery (available for COS numbers 1-62)*
 - *Auto Forwarding (available for COS numbers 1-63)*
 - *Caller ID Callback (available for COS numbers 1-64)*
 - *Call Transfer to Outside (available for COS numbers 1-62)*

To access the menu for Class of Service Numbers 1-64, follow the menu path as shown:

System Administration Top Menu-1-2-COS No.(1-64)

Note

In Table B-7 and Table B-8, sub-parameters can be assigned only when the corresponding authorization parameter is set to "Yes".

Class of Service Setting

COS Nos. 1-62 (for subscribers)

To access the menu for Class of Service Numbers 1-62 for subscribers, follow the menu path as shown:

System Administration Top Menu-1-2-COS No.(1-62)

Table B-7

Parameter	Value Range (Default)	Description/Function
New Message Retention Time	1-30 days 0: Unlimited (30)	Defines the number of days that an unplayed message will remain in the mailbox. The storage period begins the day after the message reception.
Saved Message Retention Time	1-30 days 0: Unlimited (30)	Defines the number of days that a played message will remain in the mailbox. The timing is "refreshed" whenever the message is played back. If "0: Unlimited" is selected, the saved message will remain in the mailbox until erased by the subscriber.
Message Length	1-6 min 0: Unlimited (3)	Defines the maximum message length. If set to "0: Unlimited", a subscriber can record two-way conversations of unlimited length into his or another person's mailbox (Two-Way Recording or Two-Way Transfer). The maximum recording time for other messages will automatically be set to 6 min.
Mailbox Capacity Maximum Messages	5-100 msgs (100)	Specifies the maximum number of (both new and saved) messages that can be stored in a mailbox.
Mailbox Capacity Maximum Message Time	5-100 min 0: Unlimited (100)	Specifies the total number of available minutes for storing (both new and saved) messages in each mailbox.
Message Retrieval Order	1. LIFO 2. FIFO (LIFO)	Specifies the order in which messages will be retrieved (played back for listening). LIFO: Messages are retrieved starting with the most recent. FIFO: Messages are retrieved starting with the oldest.
Message Scanning with Information	1. Yes 2. No (No)	If set to "Yes", the VPS adds the message sender's name and the recording date and time to the message during the message scan.

Table B-7

Parameter	Value Range (Default)	Description/Function
Envelope Information Position	1. Before 2. After 3. None (Before)	<p>Specifies the position of Envelope Information—the name of the person who recorded/transferred a message, or Caller ID Number information</p> <p>Before: The VPS announces Envelope Information before playing the recorded/transferred message.</p> <p>After: The VPS announces Envelope Information after playing the recorded message.</p> <p>None: The VPS does not announce Envelope Information.</p> <p>Note If you want to skip this information, press 6 while hearing it.</p>
Time and Date Stamp Position	1. Before 2. After 3. None (After)	<p>Specifies the position of Time and Date Stamp</p> <p>Before: The VPS announces Time and Date Stamp before playing the recorded/transferred message.</p> <p>After: The VPS announces Time and Date Stamp after playing the recorded message.</p> <p>None: The VPS does not announce Time and Date Stamp.</p> <p>Note If you want to skip this information, press 6 while hearing it.</p>
Caller ID Callback	1. Yes 2. No (No)	If set to "Yes", a subscriber is able to call back the message sender with the Caller ID number attached to the message.
Prompt Mode	1. System 2. User 1 3. User 2 (User 1)	<p>Specifies the language used for voice prompts played for the subscriber during a Message Waiting Notification Call and Subscriber Service.</p> <p>Note If the specified Prompts are not recorded by the Message Manager, the VPS will automatically play the factory-recorded System prompts in English.</p>
Delete Message Confirmation	1. Yes 2. No (No)	If set to "Yes", the VPS requests confirmation from the mailbox owner before erasing a message left in the mailbox. If set to "No", the message is erased immediately.

Table B-7

Parameter	Value Range (Default)	Description/Function
Direct Mailbox Access	1. Yes 2. No (Yes)	<p>If set to "Yes", a subscriber is able to directly enter Subscriber Service. This is accomplished by calling a VPS extension directly from the subscriber's extension. The Subscriber Service Access Code ("×" and mailbox number) need not be dialed. Password entry may be required if specified beforehand.</p> <p>Note The Direct Mailbox Access feature is only available if DPT Voice Mail Integration is activated with a Panasonic KX-T series telephone system.</p>
Remote Call FWD to CO	1. Yes 2. No (No)	<p>If set to "Yes", Remote Call Forwarding can be set to an outside (CO) line; a subscriber can program his extension from a remote location to forward various types of calls to either "Telephone No.1" or "Telephone No.2" (preprogrammed in the Mailbox Setting), or to any other telephone number.</p> <p>Note The Remote Call FWD to CO feature is available if DPT Voice Mail Integration is activated with a Panasonic KX-T series telephone system.</p> <p>Notice With respect to PBX programming, it is possible that "Call Forward to CO" is disabled. To enable VPS Remote Call Forwarding, the KX-TD1232, for example, must be programmed properly. For the COS of the extensions whose calls are to be forwarded to a CO line, enable the following: [504] Call Forward to Outside Line.</p>
Play System Prompt after Personal Greeting	1. Yes 2. No (No)	<p>If set to "Yes", directions for recording a message are given to the caller immediately after the personal greeting has been played.</p> <p>The following guidance messages are played: <i>"To end recording, hang up or press 1 for more features".</i> <i>"To pause and restart recording, press 2".</i></p>
Use Call Waiting on Busy	1. Yes 2. No (No)	<p>If set to "Yes", the VPS signals the busy extension that another call is waiting.</p> <p>Note To use Call Waiting on Busy, you must also enable the use of the Call Waiting feature at your PBX.</p>

Table B-7

Parameter	Value Range (Default)	Description/Function
Message Cancel for Live Call Screening	1. Yes 2. No (Yes)	<p>The Live Call Screening feature permits the subscriber to monitor incoming messages as they are being recorded, or intercept them if desired. If the subscriber chooses to speak to the caller, if not disabled by the PBX beforehand, the VPS will record the two-way conversation. If set to "Yes", the VPS will automatically delete this recording.</p> <p>The two-way conversation may be saved in the mailbox if the PBX allows the conversation to be recorded. If set to "No", the recording will be automatically saved.</p> <p>Note</p> <p>The Live Call Screening feature is available if DPT Voice Mail Integration is activated with a Panasonic KX-T series telephone system.</p>
Intercom Paging Group	1-17 (Group 1)	<p>Specifies the Intercom Paging group number available to the subscriber.</p> <p>If set to "17", the Intercom Paging feature is activated for all groups.</p> <p>Note</p> <p>The Intercom Paging feature is available if DPT Voice Mail Integration is activated with a Panasonic KX-T series telephone system.</p>
Number of CIDs for Caller Name Announcement	0-30 (30)	Specifies the maximum number of Caller IDs which subscribers can assign for the Personal Caller Name Announcement.
Personal Greeting for CID	1. Yes 2. No (Yes)	If set to "Yes", subscribers can utilize the personal greeting feature for Caller ID.
Caller ID Screening	1. Yes 2. No (Yes)	If set to "Yes", subscribers can utilize the Caller ID Screening feature.
Call Transfer to Outside	1. Yes 2. No (No)	If set to "Yes", the VPS enables a call to be transferred to an outside line from the following services: Call Transfer Service, and Personal Custom Service.

Table B-7

Parameter	Value Range (Default)	Description/Function
Toll Saver	1. No 2. DID 3. Caller ID (No)	Permits a subscriber to check his mailbox from pre-assigned Caller ID numbers or by dialing a pre-assigned DID number without telephone charges. No: Disables the Toll Saver feature. DID: A subscriber can check his mailbox by dialing a pre-assigned DID number without telephone charges. Caller ID: A subscriber can check his mailbox from a pre-assigned Caller ID number without telephone charges. Note DID number setting for this feature is only available when the VPS is connected to the following PBXs with DPT Integration. <ul style="list-style-type: none"> • KX-TD816 (P311Q or higher) • KX-TD1232 (P211Q or higher) • KX-TD500 (V4M or higher)
Subscriber Tutorial	1. Yes 2. No (Yes)	If set to "Yes", a subscriber is guided to set the following basic mailbox settings automatically only when he accesses his mailbox for the first time: <ol style="list-style-type: none"> 1. Password 2. Owner's Name 3. Personal Greetings—No Answer 4. Personal Greetings—Busy 5. Personal Greetings—After Hours

Table B-7

Parameter	Value Range (Default)	Description/Function
Authorization for Message Notification	1. Yes 2. No (Yes)	If set to "Yes", subscribers are able to utilize the Message Waiting Notification feature. The sub-parameters to be set include Beeper Callback No. Entry Mode, MWL Notification for Unreceived Message, and Device Notification for Unreceived Message. If set to "No", sub-parameters cannot be assigned. Note This parameter in COS No.1 is set to "Yes" when the Quick Setup procedure is used to create Subscriber Mailboxes.
Beeper Callback No. Entry Mode	1. Caller Select 2. Without 3. Before 4. After 5. Disable (Disable)	Permits subscribers to use the Callback Number Entry feature. Caller Select: After recording a message, the caller is asked if the message is urgent. If urgent, the caller is asked to enter the callback number. Without: Without recording a message, the caller is asked to enter the callback number. Before: Before recording a message, the VPS asks the caller to enter the callback number. After: After recording a message, the VPS asks the caller to enter the callback number. Disable: Disables the Callback Number Entry feature. Note To utilize this feature, the callback number entry code must be included in the subscriber's beeper number. When "Disable" is selected or if the caller does not enter a callback number, "System Callback No." (see Table B-28) will be displayed on the beeper's display. If a caller's number is received through a telephone company's Caller ID service, the caller's number will be displayed instead of "System Callback No.".

Table B-7

Parameter	Value Range (Default)	Description/Function
MWL Notification for Unreceived Message	1. Yes 2. No (Yes)	If set to "Yes", the message waiting lamp will illuminate when unplayed messages remain after the subscriber has accessed the mailbox for Subscriber Service.
Device Notification for Unreceived Message	1. Yes 2. No (No)	If set to "Yes", the VPS calls the appropriate device in numerical order until all unplayed messages are received.
Authorization for External Message Delivery	1. Yes 2. No (No)	If set to "Yes", subscribers are able to utilize the External Message Delivery feature. The sub-parameter to be set is Prompt Mode. If set to "No", sub-parameter cannot be assigned.
Prompt Mode	1. System 2. User 1 3. User 2 4. Selective (User 1)	When an external message is delivered, the receiver will be greeted by the VPS in the specified language (prompt). However, if "Selective" is enabled, then the receiver has a choice of prompts. See related explanation in "Incoming Call Service Prompt" in Table 5-5 in 5.3.1 Port Service Menu. Note When "Selective" is enabled and the receiver uses a rotary telephone, the no-entry selection is specified by "Prompt for Rotary Callers" in Table 5-5 in 5.3.1 Port Service Menu.
Authorization for Auto Forwarding	1. Yes 2. No (No)	If set to "Yes", the VPS automatically forwards messages that have not been accessed for a specific length of time to another mailbox. The sub-parameters to be set for this feature include Mailbox Number, Delay Time, and Forwarding Mode. If set to "No", sub-parameters cannot be assigned.
Mailbox Number	2-5 digits (None)	Specifies the mailbox to which the messages will be forwarded. Note The numbers of the System Group Distribution List cannot be specified as the destination.

Table B-7

Parameter	Value Range (Default)	Description/Function
Delay Time	(h) (min) 00:05 to 99:59 (00:30)	Specifies the length of time in hours and minutes that the VPS must wait before forwarding unretrieved messages. The maximum delay time is 99 h, 59 min. Note The delay time must be less than the New Message Retention Time, or else messages will be deleted before being forwarded.
Forwarding Mode	1. Copy 2. Move (Move)	Specifies if forwarded messages are to be retained in the original mailbox. When set to "Copy", copies of the messages are retained in the original mailbox after forwarding. When set to "Move", messages are forwarded to the receiving mailbox and are not retained at the original location.

COS Nos. 63 & 64 (for Managers)

To access the menu for Class of Service Numbers 63 & 64 for Managers, follow the menu path as shown:

System Administration Top Menu-1-2-COS No.(63-64)

Only the parameters listed below can be assigned for COS numbers 63 and 64. COS number 64 cannot assign the last 4 parameters—Direct Mailbox Access, Remote Call FWD to CO, Authorization for Message Notification, and Authorization for Auto Forwarding.

Table B-8

Parameter	Value Range (Default)	Description/Function
New Message Retention Time	1-30 days 0: Unlimited (30)	Defines the number of days that an unplayed message can remain in the mailbox. The storage period begins the day after the message reception.
Saved Message Retention Time	1-30 days 0: Unlimited (30)	Defines the number of days a played saved message will remain in the mailbox. The timing is "refreshed" whenever the message is played back. If "0: Unlimited" is selected, saved messages will remain in the mailbox until erased by the mailbox owner.

Table B-8

Parameter	Value Range (Default)	Description/Function
Message Length	1-6 min 0: Unlimited (6)	Defines the maximum message length. If set to "0: Unlimited", a manager can record two-way conversations of unlimited length into his or another person's mailbox (Two-Way Recording or Two-Way Transfer). The maximum recording time for other messages will automatically be set to 6 min.
Mailbox Capacity Maximum Messages	5-100 msgs (100)	Specifies the maximum number of (both new and saved) messages that can be stored in a mailbox.
Mailbox Capacity Maximum Message Time	5-100 min 0: Unlimited (100)	Specifies the total number of available minutes for storing (both new and saved) messages in each mailbox.
Message Retrieval Order	1. LIFO 2. FIFO (LIFO)	Specifies the order in which messages will be retrieved (played back for listening). LIFO: Messages are retrieved starting with the most recent. FIFO: Messages are retrieved starting with the oldest.
Message Scanning with Information	1. Yes 2. No (No)	If set to "Yes", the VPS adds the message sender's name and the recording date and time to the message during the message scan.
Prompt Mode	1. System 2. User 1 3. User 2 (User 1)	Specifies the language used for voice prompts. Note If the specified Prompts are not recorded by the Message Manager, the VPS will automatically play the factory-recorded System prompts in English.
Delete Message Confirmation	1. Yes 2. No (No)	If set to "Yes", the VPS requests confirmation from the mailbox owner before erasing a message left in the mailbox. If set to "No", the message is erased immediately.

Table B-8

Parameter	Value Range (Default)	Description/Function
Envelope Information Position	1. Before 2. After 3. None (Before)	<p>Specifies the position of Envelope Information—the name of the person who recorded/transferred a message, or Caller ID Number information</p> <p>Before: The VPS announces Envelope Information before playing the recorded/transferred message.</p> <p>After: The VPS announces Envelope Information after playing the recorded message.</p> <p>None: The VPS does not announce Envelope Information.</p> <p>Note If you want to skip this information, press 6 while hearing it.</p>
Time and Date Stamp Position	1. Before 2. After 3. None (After)	<p>Specifies the position of Time and Date Stamp</p> <p>Before: The VPS announces Time and Date Stamp before playing the recorded/transferred message.</p> <p>After: The VPS announces Time and Date Stamp after playing the recorded message.</p> <p>None: The VPS does not announce Time and Date Stamp.</p> <p>Note If you want to skip this information, press 6 while hearing it.</p>
Caller ID Callback	1. Yes 2. No (No)	<p>If set to "Yes", a subscriber is able to call back the message sender with the Caller ID number attached to the message.</p>
Direct Mailbox Access	1. Yes 2. No (Yes)	<p>If set to "Yes", a subscriber is able to directly enter Subscriber Service. This is accomplished by calling a VPS extension directly from the subscriber's extension. The Subscriber Service Access Code ("*" and mailbox number) need not be dialed. Password entry may be required if specified beforehand.</p> <p>Note The Direct Mailbox Access feature is only available if DPT Voice Mail Integration is activated with a Panasonic KX-T series telephone system.</p>

Table B-8

Parameter	Value Range (Default)	Description/Function
Remote Call FWD to CO	1. Yes 2. No (No)	<p>If set to "Yes", Remote Call Forwarding can be set to an outside (CO) line; the Message Manager can program his extension from a remote location to forward various types of calls to either "Telephone No.1" or "Telephone No.2" (preprogrammed in the Mailbox Setting), or to any other telephone number.</p> <p>Note</p> <p>The Remote Call FWD to CO feature is available if DPT Voice Mail Integration is activated with a Panasonic KX-T series telephone system.</p> <p>Notice</p> <p>With respect to PBX programming, it is possible that "Call Forward to CO" is disabled. To enable VPS Remote Call Forwarding, the KX-TD1232, for example, must be programmed properly. For the COS of the extensions whose calls are to be forwarded to a CO line, enable the following: [504] Call Forward to Outside Line.</p>

Table B-8

Parameter	Value Range (Default)	Description/Function
Authorization for Message Notification	1. Yes 2. No (Yes)	If set to "Yes", the Message Manager is able to utilize the Message Waiting Notification feature. The sub-parameters to be set include Beeper Callback No. Entry Mode, MWL Notification for Unreceived Message, and Device Notification for Unreceived Message. If set to "No", sub-parameters cannot be assigned.
Beeper Callback No. Entry Mode	1. Caller Select 2. Without 3. Before 4. After 5. Disable (Disable)	<p>Permits the Message Manager to use the Callback Number Entry feature.</p> <p>Caller Select: After recording a message, the caller is asked if the message is urgent. If urgent, the caller is asked to enter the callback number.</p> <p>Without: Without recording a message, the caller is asked to enter the callback number.</p> <p>Before: Before recording a message, the VPS asks the caller to enter the callback number.</p> <p>After: After recording a message, the VPS asks the caller to enter the callback number.</p> <p>Disable: Disables the Callback Number Entry feature.</p> <p>Note</p> <p>To utilize this feature, the callback number entry code must be included in the subscriber's beeper number. When "Disable" is selected or if the caller does not enter a callback number, "System Callback No." (see Table B-28) will be displayed on the beeper's display. If a caller's number is received through a telephone company's Caller ID service, the caller's number will be displayed instead of "System Callback No.".</p>
MWL Notification for Unreceived Message	1. Yes 2. No (Yes)	If set to "Yes", the message waiting lamp illuminates when unplayed messages remain after the Message Manager has accessed the mailbox.
Device Notification for Unreceived Message	1. Yes 2. No (No)	If set to "Yes", the VPS calls the appropriate device in numerical order until all unplayed messages are received.

Table B-8

Parameter	Value Range (Default)	Description/Function
Authorization for Auto Forwarding	1. Yes 2. No (No)	If set to "Yes", the VPS automatically forwards messages that have not been accessed for a specific length of time to another mailbox. The sub-parameters to be set for this feature include Mailbox Number, Delay Time, and Forwarding Mode. If set to "No", sub-parameters cannot be assigned.
Mailbox Number	2-5 digits (None)	Specifies the mailbox to which the messages will be forwarded. Note The numbers of the System Group Distribution List cannot be specified as the destination.
Delay Time	(h) (min) 00:05 to 99:59 (00:30)	Specifies the length of time in hours and minutes that the VPS must wait before forwarding unretrieved messages. The maximum delay time is 99 h, 59 min. Note The delay time must be less than the New Message Retention Time, or else messages will be deleted before being forwarded.
Forwarding Mode	1. Copy 2. Move (Move)	Specifies if forwarded messages are to be retained in the original mailbox. When set to "Copy", copies of the messages are retained in the original mailbox after forwarding. When set to "Move", messages are forwarded to the receiving mailbox and are not retained at the original location.

B4 SYSTEM ADMINISTRATION—PORT/TRUNK SERVICE

One of 4 incoming call services can be assigned to each VPS port and each PBX trunk (CO line) group: Voice Mail, Automated Attendant, Interview, or Custom Service.

The Port Assignment menu and Trunk Group Assignment menu allow the Company Greeting Number, Prompt Mode, Delayed Answer Time, and Time Group Number to be programmed.

Services have this order of priority:

Toll Saver > Holiday Service > Caller ID Call Routing > DID Call Routing > Trunk Service > Port Service
(Toll Saver has the highest priority.)

To access the menu for Port/Trunk Service Menu, follow the menu path as shown:

System Administration Top Menu-1-3

B4.1 Port Assignment

To access the menu for Day, Night, Lunch or Break Mode for the selected port, follow the menu path as shown:

System Administration Top Menu-1-3-1-Port No.(1-24)

Note

The maximum number of ports depends on the VPS model.

Port (1-24)-Day Mode

To access the menu for Day Mode features for the selected port, follow the menu path as shown:

System Administration Top Menu-1-3-1-Port No.(1-24)-1

Table B-9

Parameter	Value Range (Default)	Description/Function
Company Greeting No.	1-32 S: System Greeting N: None (None)	Specifies the company greeting to be played on the port. The System Greeting is: <i>"Good Morning/Afternoon/Evening. Welcome to the Voice Processing System"</i> .
Incoming Call Service	1. Voice Mail 2. Auto. Attn. 3. Interview 4. Custom (Auto. Attn.)	Specifies one of 4 incoming call services. Notes <ul style="list-style-type: none"> When you specify the Interview Service, one of subscriber's Interview Mailbox numbers should also be specified. When you specify the Custom service, one of 100 (1-100) Custom service numbers should also be specified. The System manager can change the "Incoming Call Service" remotely by simply calling the VPS (see C6 CHANGING THE COMPANY GREETING AND INCOMING CALL SERVICE SETTING).
Incoming Call Service Prompt	1. System 2. User 1 3. User 2 4. Selective (User 1)	Specifies the language of voice prompts to be played on this port. When set to "Selective", the caller can select the language of his choice, provided the Message Manager has recorded the Multilingual Selection Menu and the System Administrator has specified Prompt Selection Number. To specify Prompt Selection Number, see "System Prompt Selection Number", "User 1 Prompt Selection Number", and "User 2 Prompt Selection Number" in Table B-28 in B6.5 Prompt Setting. Note If "Selective" is specified, you will need to select a prompt available for rotary callers. See "Prompt for Rotary Callers" below.
Prompt for Rotary Callers	1. System 2. User 1 3. User 2 (System)	Specifies which language (System/User 1/User 2) a rotary caller or an External Delivery Message receiver hears when he cannot enter any digit (Prompt Selection Number) after the Multilingual Selection Menu has been played. Note "Prompt for Rotary Callers" can be assigned only when "Incoming Call Service Prompt" is set to "Selective".
Delayed Answer Time	0-60 s (0)	Specifies whether the port answers immediately (0) or with delay (1-60 s).
Time Group No.	1-8 (1)	Assigns a time group number to the port.

Port (1-24)-Night Mode

To access the menu for Night Mode features for the selected port, follow the menu path as shown:

System Administration Top Menu-1-3-1-Port No.(1-24)-2

Port (1-24)-Lunch Mode

To access the menu for Lunch Mode features for the selected port, follow the menu path as shown:

System Administration Top Menu-1-3-1-Port No.(1-24)-3

Port (1-24)-Break Mode

To access the menu for Break Mode features for the selected port, follow the menu path as shown:

System Administration Top Menu-1-3-1-Port No.(1-24)-4

B4.2 Trunk Group Assignment

This assignment is effective only with DPT Integration.

To access the menu for Day, Night, Lunch or Break Mode for the selected PBX trunk (CO line) group, follow the menu path as shown:

System Administration Top Menu-1-3-2-Trunk Group No.(1-48)

Note

For KX-TD series (except for KX-TD500), "trunk (CO line) group number" in this section (assignment) means "CO line number".

Trunk (1-48)-Day Mode

To access the menu for Day Mode features for the selected PBX trunk (CO line) group, follow the menu path as shown:

System Administration Top Menu-1-3-2-Trunk Group No.(1-48)-1

Table B-10

Parameter	Value Range (Default)	Description/Function
Company Greeting No.	1-32 S: System Greeting N: None (None)	Specifies the company greeting to be played on the trunk (CO line) group. The System Greeting is: <i>"Good Morning/Afternoon/Evening. Welcome to the Voice Processing System"</i> .
Incoming Call Service	1. Voice Mail 2. Auto. Attn. 3. Interview 4. Custom 5. None (None)	Specifies one of 4 incoming call services. Notes <ul style="list-style-type: none"> • When you specify the Interview Service, one of subscriber's Interview Mailbox numbers should also be specified. • When you specify the Custom service, one of 100 (1-100) Custom service numbers should also be specified. • The System Manager can change the "Incoming Call Service" remotely by simply calling the VPS (see C6 CHANGING THE COMPANY GREETING AND INCOMING CALL SERVICE SETTING).
Incoming Call Service Prompt	1. System 2. User 1 3. User 2 4. Selective (User 1)	Specifies the language of voice prompts to be played on this trunk (CO line) group. When set to "Selective", the caller can select the language of his choice, provided the Message Manager has recorded the Multilingual Selection Menu and the System Administrator has specified Prompt Selection Number. To specify Prompt Selection Number, see "System Prompt Selection Number", "User 1 Prompt Selection Number", and "User 2 Prompt Selection Number" in Table B-28 in B6.5 Prompt Setting. Note If "Selective" is specified, you will need to select a prompt available for rotary callers. See "Prompt for Rotary Callers" below.
Prompt for Rotary Callers	1. System 2. User 1 3. User 2 (System)	Specifies which language (System/User 1/User 2) a rotary caller or an External Delivery Message receiver hears when he cannot enter any digit (Prompt Selection Number) after the Multilingual Selection Menu has been played. Note "Prompt for Rotary Callers" can be assigned only when "Incoming Call Service Prompt" is set to "Selective".

Table B-10

Parameter	Value Range (Default)	Description/Function
Delayed Answer Time	0-60 s (0)	Specifies whether the trunk (CO line) group answers immediately (0) or with delay (1-60 s).
Time Group No.	1-8 (1)	Assigns a time group number to the trunk (CO line) group.

Trunk (1-48)-Night Mode

To access the menu for Night Mode features for the selected PBX trunk (CO line) group, follow the menu path as shown:

System Administration Top Menu-1-3-2-Trunk Group No.(1-48)-2

Trunk (1-48)-Lunch Mode

To access the menu for Lunch Mode Features for PBX trunk (CO line) group, follow the menu path as shown:

System Administration Top Menu-1-3-2-Trunk Group No.(1-48)-3

Trunk (1-48)-Break Mode

To access the menu for Break Mode Features for the selected PBX trunk (CO line) group, follow the menu path as shown:

System Administration Top Menu-1-3-2-Trunk Group No.(1-48)-4

B5 SYSTEM ADMINISTRATION—SERVICE SETTINGS

B5.1 Automated Attendant Parameters

The Automated Attendant Service has 3 main functions: Department or Speed Dialing, Operator's Parameters, and Alternate Extension.

To access the menu for Automated Attendant Parameters, follow the menu path as shown:

System Administration Top Menu-1-4-1

Department Dialing

Department Dialing is a speed-dialing feature that permits a caller to reach the intended extension by dialing a single digit (1-9).

To access the menu for Department Dialing, follow the menu path as shown:

System Administration Top Menu-1-4-1-1

Table B-11

Parameter	Value Range (Default)	Description/Function
Department Dialing No.1-9	2-5 digits (None)	Specifies the department extension number. Notes <ul style="list-style-type: none"> The Extension Group List or Logical Extension Numbers cannot be assigned. The Message Manager must record the Department Dialing menu.

Operator's Parameters

Use these parameters to specify the operator's (operator 1, 2, 3) extensions and mailboxes, as well as how to treat operator-seeking calls.

Operator's parameters can be individually set for Day, Night, Lunch and Break Modes.

To access the menu for Operator's Parameters, follow the menu path as shown:

System Administration Top Menu-1-4-1-2

Operator’s Parameters-Day Mode-Operator 1

Use this parameter to enable or disable the Operator Service. It specifies Operator 1’s extension and the treatment of the calls transferred to that extension. The extension number assigned for Operator 1 in the Day Mode will be for the Message Manager. When Operator service is enabled, operator-seeking calls first reach Operator 1’s extension.

Notes

- Because the extension number assigned for Operator 1 in the Day Mode is for the Message Manager, you cannot assign this extension to any other mailbox.
- By default, the extension number for the Message Manager’s extension (assigned for Operator 1 in the Day Mode) is "0". However, the default setting cannot be used with the Message Waiting Notification—Lamp feature and the Remote Call Forwarding Set feature. When using these features, You must assign the extension number that is included in the Extension Numbering Plan.

To access the menu for Operator Parameters-Day Mode-Operator 1, follow the menu path as shown:

System Administration Top Menu-1-4-1-2-1-1

Table B-12

Parameter	Value Range (Default)	Description/Function
Operator Service	1. Disable 2. Enable (Enable)	Enables or disables the Operator Service feature. Note All non-touchtone input calls in Automated Attendant Service will be transferred to the General Delivery Mailbox when the Operator Service is disabled.
Operator’s Extension	1-5 digits (0)	Specifies the extension number for Operator 1. Notes <ul style="list-style-type: none"> • The default setting (0) cannot be used with the Message Waiting Notification—Lamp feature. An extension number must be assigned that is included in the Extension Numbering Plan. • The extension number must not be assigned anywhere else (in particular, the extension must not have a mailbox). Otherwise, you will get an error message.
Operator’s Mailbox No.	2-5 digits (KX-TVS125/KX-TVS225: 998; KX-TVS325: 9998)	Callers to Operator 1 are prompted to leave a message in this mailbox depending upon how the Busy Coverage or No Answer Coverage modes are set.

Table B-12

Parameter	Value Range (Default)	Description/Function
Operator No Answer Time	10-60 s (30)	When a call to Operator 1, 2, or 3 is not answered within the time set, the VPS will offer other options as defined by the "No Answer Coverage Mode". Notes <ul style="list-style-type: none"> This timer applies to Operator 1, 2, and 3. If more than 1 operator is assigned, we recommend to reduce the time on the "Operator No Answer Time" to 15 s.
Busy Coverage Mode	1. Hold 2. No Answer Coverage 3. Call Waiting 4. Disconnect Message (Hold)	Specifies how to handle calls when the Operator 1 extension is busy. 1. Hold—Automatically places the caller on hold and the Operator 1 extension is called again. 2. No Answer Coverage—Offers the option specified by the No Answer Coverage Mode to the caller. 3. Call Waiting—Signals the Operator 1 when another call is waiting using the Call Waiting feature of the PBX. 4. Disconnect Message—Disconnects the caller after playing "Thank you for calling".
No Answer Coverage Mode	1. Caller Select 2. Leave Message 3. Disconnect Message 4. Next Operator (Caller Select)	Specifies how to handle Operator 1 calls when not answered within the time period set by the "Operator No Answer Time" mode. 1. Caller Select*—Allows the caller to leave a message or call another extension. (In some cases, a call to another extension is not available). 2. Leave Message—Instructs the caller to leave a message in Operator 1's mailbox. 3. Disconnect Message—Disconnects the caller after playing "Thank you for calling". 4. Next Operator—Transfers the caller to Operator 2.
Message Repeat Cycle	1-3 times (3)	Specifies the number of times the VPS will play the Automated Attendant top menu.

- * ***In the following cases, the caller cannot "select". He is directed to Operator 1's mailbox when he is transferred to the operator but the operator does not answer:***
- No input to Automated Attendant.***
 - No input to Custom Service menu when "No DTMF Input Operation" is set to "C. Operator" in Table B-16 in B5.2 Custom Service.***

- **No input to Voice Mail service when "Rotary Telephone Call Coverage (Day/Night/Lunch/Break)" is set to "Operator Extension" in Table B-36 in B6.8 Other Parameters.**

Note

Extension Call Forwarding to the VPS can override the operator call coverage settings depending on the timing parameters of the PBX and VPS. Even if the operator call coverage parameters are set to "Next Operator" on Busy/No Answer, the call may go to the VPS (if the Operator has set the call forwarding to the VPS).

Operator’s Parameters-Day Mode-Operator 2

Operator 2 receives operator-seeking calls when Operator 1 is busy or does not answer and Operator 1’s parameters are set as follows:

- Busy Coverage Mode—No Answer Coverage
- No Answer Coverage Mode—Next Operator

To access the menu for Operator Parameters-Day Mode-Operator 2, follow the menu path as shown:

System Administration Top Menu-1-4-1-2-1-2

Table B-13

Parameter	Value Range (Default)	Description/Function
Operator’s Extension	1-5 digits (None)	Specifies the extension number for Operator 2. Any valid extension number can be assigned.
Operator’s Mailbox No.	2-5 digits (None)	Specifies the mailbox number for Operator 2. Callers to Operator 2 are prompted to leave a message in this mailbox depending upon how the Busy Coverage or No Answer Coverage modes are set.
Busy Coverage Mode	1. Hold 2. No Answer Coverage 3. Call Waiting 4. Disconnect Message (Hold)	Specifies how to handle calls when the Operator 2 extension is busy. 1. Hold—Automatically places the caller on hold and the Operator 2 extension is called again. 2. No Answer Coverage—Offers the option specified by the No Answer Coverage Mode to the caller. 3. Call Waiting—Signals the Operator 2 when another call is waiting using the Call Waiting feature of the PBX. 4. Disconnect Message—Disconnects the call after playing "Thank you for calling".

Table B-13

Parameter	Value Range (Default)	Description/Function
No Answer Coverage Mode	1. Caller Select 2. Leave Message 3. Disconnect Message 4. Next Operator (Caller Select)	Specifies how to handle Operator 2 calls when not answered within the time period set by the "Operator No Answer Time" mode. 1. Caller Select*—Allows the caller to leave a message or call another extension. (In some cases, a call to another extension is not available. 2. Leave Message—Instructs the caller to leave a message in Operator 2's mailbox. 3. Disconnect Message—Disconnects the caller after playing "Thank you for calling". 4. Next Operator—Transfers the caller to Operator 3.

* *In the following cases, the caller cannot "select". He is directed to Operator 1's mailbox when he is transferred to the operator but the operator does not answer:*

- *No input to Automated Attendant.*
- *No input to Custom Service menu when "No DTMF Input Operation" is set to "C. Operator" in Table B-16 in B5.2 Custom Service.*
- *No input to Voice Mail service when "Rotary Telephone Call Coverage (Day/Night/Lunch/Break)" is set to "Operator Extension" in Table B-36 in B6.8 Other Parameters.*

Operator's Parameters-Day Mode-Operator 3

Operator 3 receives operator-seeking calls when Operator 2 is busy or unanswered and Operator 2's parameters are set as follows:

- Busy Coverage Mode—No Answer Coverage
- No Answer Coverage Mode—next Operator

To access the menu for Operator Parameters-Day Mode-Operator 3, follow the menu path as shown:

System Administration Top Menu-1-4-1-2-1-3

Table B-14

Parameter	Value Range (Default)	Description/Function
Operator's Extension	1-5 digits (None)	Specifies the extension number for Operator 3. Any valid extension number can be assigned.

Table B-14

Parameter	Value Range (Default)	Description/Function
Operator's Mailbox No.	2-5 digits (None)	Specifies the mailbox number for Operator 3. Callers to Operator 3 are prompted to leave a message in this mailbox depending upon how the Busy Coverage or No Answer Coverage modes are set.
Busy Coverage Mode	1. Hold 2. No Answer Coverage 3. Call Waiting 4. Disconnect Message (Hold)	Specifies how to handle calls when the Operator 3 extension is busy. 1. Hold—Automatically places the caller on hold and the Operator 3 extension is called again. 2. No Answer Coverage—Offers the option specified by the No Answer Coverage Mode to the caller. 3. Call Waiting—Signals Operator 3 when another call is waiting using the Call Waiting feature of the PBX. 4. Disconnect Message—Disconnects the call after playing "Thank you for calling".
No Answer Coverage Mode	1. Caller Select 2. Leave Message 3. Disconnect Message (Caller Select)	Specifies how to handle Operator 3 calls when not answered within the time period set by the "Operator No Answer Time" mode. 1. Caller Select*—Allows the caller to leave a message or call another extension. (In some cases, a call to another extension is not available.) 2. Leave Message—Instructs the caller to leave a message in Operator 3's mailbox. 3. Disconnect message—Disconnects the caller after playing "Thank you for calling".

* *In the following cases, the caller cannot "select". He is directed to Operator 1's mailbox when he is transferred to the operator but the operator does not answer:*

- *No input to Automated Attendant.*
- *No input to Custom Service menu when "No DTMF Input Operation" is set to "C. Operator" in Table B-16 in B5.2 Custom Service.*
- *No input to Voice Mail service when "Rotary Telephone Call Coverage (Day/Night/Lunch/Break)" is set to "Operator Extension" in Table B-36 in B6.8 Other Parameters.*

Notes

- An operator-seeking call will always reach Operator 1 first. The call will then be transferred to Operator 2 and Operator 3 sequentially, depending on system programming.
- "Next Operator" is not applicable for "No Answer Coverage Mode" of Operator 3.

Operator’s Parameters-Night Mode-Operator 1, 2, 3

Same as Day Mode.

Operator’s Parameters-Lunch Mode-Operator 1, 2, 3

Same as Day Mode.

Operator’s Parameters-Break Mode-Operator 1, 2, 3

Same as Day Mode.

Alternate Extension Assignment

Assigns extensions that should be transferred differently from the normal extension transfer sequence. Calls to the extensions in this group will be transferred following the sequence defined by "Alternate Extension Transfer Sequence" (see "Alternate Extension Transfer Sequence" in Table B-45 in B7.3 PBX Interface Parameters).

To access the menu for Alternate Extension Assignment Parameter, follow the menu path as shown:

System Administration Top Menu-1-4-1-3

Alternate Extension Group-Enter

The system can create up to 32 extensions that use the same alternate transfer sequence.

To access the menu for Alternate Extension-Enter Parameter, follow the menu path as shown:

System Administration Top Menu-1-4-1-3-1

Table B-15

Parameter	Value Range (Default)	Description/Function
Alternate Extension (1-32)	2-5 digits (None)	Specifies an extension, which requires a different transfer sequence than normal. Note The Extension Group List or Logical Extension Numbers cannot be assigned.

Alternate Extension-Delete

The system can delete extension numbers from the alternate extension group.

To access the menu for Alternate Extension-Delete Parameter, follow the menu path as shown:

System Administration Top Menu-1-4-1-3-2

Alternate Extension-Listing

Lists all of the extensions registered in the alternate extension group.

To access the menu for Alternate Extension-Listing Parameter, follow the menu path as shown:

System Administration Top Menu-1-4-1-3-3

B5.2 Custom Service

Custom Service is one of 4 incoming call services. By assigning a function to each key, you can provide callers with a customized key operation service. You can establish a maximum of 100 Custom Services with the possible depth of 8 layers. The Message Manager should record Custom Service Menus so that callers will know which key to press.

Note

Callers cannot jump between Custom Service menus more than 8 times.

To access the menu for Custom Service Parameter, follow the menu path as shown:

System Administration Top Menu-1-4-2-Custom Service No.(1-100)

Table B-16

Parameter	Value Range (Default)	Description/Function
Description	Up to 32 characters (None)	The information typed in this field is for reference only. Any ASCII character (except \) can be used.
Prompt Mode	1. System 2. User 1 3. User 2 (System)	Specifies the language of services within Custom Service. Note This parameter overrides "Incoming Call Service Prompt".
Menu Repeat Cycle	1-3 times (3)	Specifies the number of times Custom Service menu messages will be repeated to the caller.

Table B-16

Parameter	Value Range (Default)	Description/Function
Call Transfer Anytime	Extn./Mbx/No (Extn.)	<p>Specifies the destination to which the call will be transferred. The "Extn." setting (enter "E") enables callers to be transferred directly to their intended party by dialing the extension number. The "Mbx" setting (enter "M") enables callers to leave messages in a mailbox by entering the mailbox number. The "No" setting (enter "N") disables extension transfer and mailbox transfer; only 1-digit entries work (following the Custom Service menu).</p> <p>Note</p> <p>This parameter should be set to "No" when Subscriber Service is specified as a Custom Service option and it is desired that digits can be entered very quickly to specify a mailbox. Therefore, in most cases, "No" is the best setting for this parameter. This is especially true if you do not want to explain "Call Transfer Any Time" in your Custom Service menu recording.</p>
Wait for Second Digit	1-5 s (1)	<p>Resolves the problem when the first digit of the extension or mailbox number is the same as one of the Custom Service menu choices. The VPS waits the specified period of time for a second digit to be dialed. If the time period expires without a second digit being entered, the system assumes the caller has selected a menu choice. Use this parameter only if "Call Transfer Anytime" is set to "Extn." or "Mbx".</p>
No DTMF Input Operation	a-f (c) *See the following "Keypad Assignment".	<p>Specifies how to handle a call when there is no response to the menu message. No response usually indicates that the caller is using a rotary phone. The factory setting is "C. Operator", which allows the caller to be automatically connected to an operator after message playback.</p>

Table B-16

Parameter	Value Range (Default)	Description/Function
<p>Keypad Assignment 0-9, *, #</p>	<p>a-n (*: d, 0: c Others: None)</p>	<p>Any of the 14 services listed below (a-n) can be assigned to the 0 through 9, *, and # keys on the telephone keypad. Callers are able to access these services by pressing the corresponding keys on their telephones.</p> <ul style="list-style-type: none"> (a) Transfer to Mailbox—Allows the caller to leave messages in a specific mailbox. Enter "a" followed by a mailbox number. (b) Transfer to Extension—Transfers the caller to a specific extension. Enter "b" followed by an extension number. (c) Operator—Connects the caller to the operator. (d) Exit—Plays the Custom Service exit prompt and disconnects the caller. The Message Manager is responsible for recording this prompt. (e) Previous Menu—If programmed, returns the caller to the previous menu. (f) Custom Service—If programmed, transfers the caller to another Custom Service. (g) Voice Mail Service—Allows the caller to access Voice Mail Service. (h) Call Transfer Service—Allows the caller to access Automated Attendant Service. (i) Subscriber Service—Allows the caller to access Subscriber Service. If this option is enabled, it is strongly recommended that each subscriber establish a password; this will prevent unauthorized callers from accidentally or intentionally accessing subscribers' mailboxes. (j) Department Dialing—Transfers the caller to the Department Dialing menu. (k) Dial by Name—Requests the caller to enter the first 3 or 4 letters of a last name of the person they wish to reach, then transfers him to the corresponding extension. (l) Repeat Menu—Repeats the Custom Service menu prompts. (m) Main Menu—Returns the caller to the Custom Service top menu. (n) FAX Transfer—Allows the caller to send fax messages to an extension specified as the fax extension. (o) Transfer to Outside—Transfers the caller to a specific outside line. Enter "o" followed by the PBX CO line access code (e.g., "9") then the destination outside telephone number.

B5.3 Intelligent Call Handling

Caller ID Call Routing

Up to 200 Caller ID numbers can be assigned to be automatically forwarded to a desired destination. The VPS automatically forwards calls from the assigned Caller ID numbers to a programmed extension, mailbox (including System Group Distribution List) or Custom Service. It also forwards "Private" (the caller's number is not received) and "Out of Area" calls to a desired extension, mailbox or Custom Service.

The company greetings will not play for calls forwarded by this feature.

Services have this order of priority:

Toll Saver > Holiday Service > Caller ID Call Routing > DID Call Routing > Trunk Service > Port Service

(Toll Saver has the highest priority.)

To access the menu for Caller ID Call Routing, follow the menu path as shown:

System Administration Top Menu-1-4-3-1

Caller ID Call Routing-Enter

To access the menu for Caller ID Call Routing-Enter, follow the menu path as shown:

System Administration Top Menu-1-4-3-1-1-Caller ID List No.(1-200)

Table B-17

Parameter	Value Range (Default)	Description/Function
Caller ID No.	P, O or Up to 20 digits consisting of 1-9, 0, * (None)	Assigns the telephone number to which the VPS applies automatic forwarding to a desired destination. "*" substitutes any number (=wild card). For example, to route all calls from Area Code 201, enter "201 *** * * * *". To have a "Private" call automatically forwarded to a desired destination, enter "P". For an "Out of Area" call, enter "O".

Table B-17

Parameter	Value Range (Default)	Description/Function
Description	Up to 20 characters (None)	Enters a name and/or description of the Caller ID number. Any ASCII character (except "\") can be used. Note When nothing is registered in this parameter but the caller's name is transmitted from the Central Office, the name will be automatically registered in this parameter. When this is done, an asterisk "×" will appear with the Call Transfer parameter if "PUTD" is enabled. See 7.2.19 Touchtone Information Display (PUTD) for more information. For example, you might see this: "Custom 3×". This indicates the name was automatically registered in the VPS.
Call Transfer (Day/Night/Lunch/Break)	Custom/Extn./Mbx/None (None)	Specifies the destination to which the call from an assigned Caller ID number is automatically forwarded. Call Transfer can be set for each Time Service period—Day, Night, Lunch, and Break. The "Custom" setting (enter "C") forwards callers to the specified Custom Service menu. The "Extn." setting (enter "E") forwards callers to the specified extension. The "Mbx" setting (enter "M") enables callers to leave messages in the specified mailbox. A System Group Distribution List number can be specified here instead of a mailbox number.

Caller ID Call Routing-Delete

Permits specified Caller ID List numbers to be deleted from the list.

To access the menu for Caller ID Call Routing-Delete, follow the menu path as shown:

System Administration Top Menu-1-4-3-1-2-Caller ID List No.(1-200)

Caller ID Call Routing-Listing

Displays all Caller ID List numbers.

To access the menu for Caller ID Call Routing-Listing, follow the menu path as shown:

System Administration Top Menu-1-4-3-1-3

DID Call Routing

Up to 200 DID numbers can be assigned to be automatically forwarded to a desired destination. The VPS automatically forwards calls from the assigned DID numbers to a programmed extension, mailbox (including System Group Distribution List) or Custom Service.

The company greetings will not play for calls forwarded by this feature.

Note

This feature is only available when the VPS is connected to the following PBXs with DPT Integration.

- KX-TD816 (P311Q or higher)
- KX-TD1232 (P211Q or higher)
- KX-TD500 (V4M or higher)

Services have this order of priority:

Toll Saver > Holiday Service > Caller ID Call Routing > DID Call Routing > Trunk Service > Port Service

(Toll Saver has the highest priority.)

To access the menu for DID Call Routing, follow the menu path as shown:

System Administration Top Menu-1-4-3-2

DID Call Routing-Enter

To access the menu for DID Call Routing-Enter, follow the menu path as shown:

System Administration Top Menu-1-4-3-2-1-DID List No.(1-200)

Table B-18

Parameter	Value Range (Default)	Description/Function
DID Number	Up to 20 digits consisting of 1-9, 0, * (None)	Assigns the telephone number to which the VPS applies automatic forwarding to a desired destination. "*" substitutes any number (=wild card). For example, to route all calls from Area Code 201, enter "201 *** * * * *".

Table B-18

Parameter	Value Range (Default)	Description/Function
Description	Up to 20 characters (None)	Enters a name and/or description of the DID number. Any ASCII character (except "\") can be used. Note When nothing is registered in this parameter but the caller's name is transmitted from the Central Office, the name will be automatically registered in this parameter. When this is done, an asterisk "×" will appear with the Call Transfer parameter if "PUTD" is enabled. See 7.2.19 Touchtone Information Display (PUTD) for more information. For example, you might see this: "Custom 3×". This indicates the name was automatically registered in the VPS.
Call Transfer (Day/Night/Lunch/Break)	Custom/Extn./Mbx (None)	Specifies the destination to which the call from an assigned DID number is automatically forwarded. Call Transfer can be set for each Time Service period—Day, Night, Lunch, and Break. The "Custom" setting (enter "C") forwards callers to the specified Custom Service menu. The "Extn." setting (enter "E") forwards callers to the specified extension. The "Mbx" setting (enter "M") enables callers to leave messages in the specified mailbox. A System Group Distribution List number can be specified here instead of a mailbox number.

DID Call Routing-Delete

Permits specified DID List numbers to be deleted from the list.

To access the menu for DID Call Routing-Delete, follow the menu path as shown:

System Administration Top Menu-1-4-3-2-2-DID List No.(1-200)

DID Call Routing-Listing

Displays all DID List numbers.

To access the menu for DID Call Routing-Listing, follow the menu path as shown:

System Administration Top Menu-1-4-3-2-3

B5.4 Toll Saver

This feature permits a subscriber to check his mailbox from pre-assigned Caller ID numbers or by dialing a pre-assigned DID number without telephone charges. When called from the assigned number, the VPS notifies the subscriber whether or not there is a new message in his mailbox by changing the delayed answer time (see Table B-19). The subscriber can reduce his telephone charges by entering his mailbox only when there is a new message. If this feature is activated, the subscriber will access his mailbox directly.

Note

DID number setting for this feature is only available when the VPS is connected to the following PBXs with DPT Integration.

- KX-TD816 (P311Q or higher)
- KX-TD1232 (P211Q or higher)
- KX-TD500 (V4M or higher)

To access the menu for Toll Saver Parameter, follow the menu path as shown:

System Administration Top Menu-1-4-4

Table B-19

Parameter	Value Range (Default)	Description/Function
Delayed Answer Time for New Message	5-60 s (12)	Specifies the length of time (in seconds) before the subscriber accesses a mailbox that has new messages.
Delayed Answer Time for No New Message	5-60 s (24)	Specifies the length of time (in seconds) before the subscriber accesses a mailbox that has no new messages.

Note

The Delayed Answer Time specified for Toll Saver has higher priority than the one specified for the Port/Trunk Service.

B6 SYSTEM ADMINISTRATION—SYSTEM PARAMETER SETTINGS

B6.1 System Group Assignment

To access the menu for System Group Assignment, follow the menu path as shown:

System Administration Top Menu-1-5-1

System Group Assignment-Mailbox Group

This parameter allows a caller to send a message simultaneously to several mailboxes. These mailboxes may be assembled into a list called a System Group Distribution List. The VPS is able to maintain up to 20 System Group Distribution Lists. Each list can have up to 20 destination mailbox numbers. Mailboxes can be added to or deleted from these lists and reviewed as needed.

To access the menu for Mailbox Group, follow the menu path as shown:

System Administration Top Menu-1-5-1-1

Mailbox Group-Enter

To access the menu for Mailbox Group-Enter, follow the menu path as shown:

System Administration Top Menu-1-5-1-1-1-Group List No.

Table B-20

Parameter	Value Range (Default)	Description/Function
Group List No.	2-5 digits (None)	Specifies any vacant mailbox number. The caller can specify that the VPS transfers or delivers messages to all members of a group by simply specifying the System Group Distribution List No.
Group Name	Up to 16 characters (None)	Specifies a group name. If a group name is not required, press RETURN, and specify the mailbox numbers. Any alphanumeric character and [(space)] can be used.
Member 1-20	2-5 digits (None)	Specifies mailbox numbers belonging to this group.

Mailbox Group-Delete

Deletes specified mailboxes from the list.

To access the menu for Mailbox Group-Delete, follow the menu path as shown:

System Administration Top Menu-1-5-1-1-2-Group List No.

Mailbox Group-Listing

Displays all System Group Distribution List numbers.

To access the menu for Mailbox Group-Listing, follow the menu path as shown:

System Administration Top Menu-1-5-1-1-3

System Group Assignment-Extension Group

You can assemble several extensions into a single list. The VPS is able to maintain up to 20 Extension Group Lists. Each list can support up to 20 extensions. You can add, delete, and review the extensions. Members within a list are able to share the same mailbox and be notified by the Message Waiting Notification—Lamp feature (if authorized) when a message is present.

Extension Group-Enter

To access the menu for Extension Group-Enter, follow the menu path as shown:

System Administration Top Menu-1-5-1-2-1-Group List No.

Table B-21

Parameter	Value Range (Default)	Description/Function
Group List No.	2-5 digits (None)	Specifies any vacant extension number. Note The Extension Group List number can be assigned as "The Extension of the Owner" of a mailbox. This permits all group members to share the information in the mailbox.
Group Name	Up to 16 characters (None)	Specifies a group name. If a group name is not required, press RETURN, and specify the mailbox numbers. Any alphanumeric character and [(space)] can be used.

Table B-21

Parameter	Value Range (Default)	Description/Function
Member 1-20	2-5 digits (None)	Specifies the extension number belonging to the group. Note Members cannot have a personal mailbox.

Extension Group-Delete

Deletes specified extensions from the list.

To access the menu for Extension Group-Delete, follow the menu path as shown:

System Administration Top Menu-1-5-1-2-2-Group List No.

Extension Group-Listing

Displays all Extension Group List numbers.

To access the menu for Extension Group List Numbers, follow the menu path as shown:

System Administration Top Menu-1-5-1-2-3

B6.2 Time Group Service

A Time Group is a time frame in which Day/Night, Lunch and Break time periods can be programmed.

The VPS maintains 8 Time Groups, and each of which can be assigned a specific setting. It is necessary to assign a specific Time Group for use in each Port and Trunk Service in its Day Mode setting menu (see "Time Group No." in Table B-9 in B4.1 Port Assignment and Table B-10 in B4.2 Trunk Group Assignment).

To access the menu for Time Group Service, follow the menu path as shown:

System Administration Top Menu-1-5-2

Time Group Service-Service Mode

The VPS automatically activates the appropriate call handling method according to the Time Service setting (Day/Night, Lunch, and Break Services) for each Time Group 1-8; however, the System Administrator or the System Manager can change the current call handling method by assigning a specific Service Mode to the desired Time Group.

To access the menu for Time Group Service-Service Mode for the selected time group, follow the menu path as shown:

System Administration Top Menu-1-5-2-1-Time Group No.(1-8)

Table B-22

Parameter	Value Range (Default)	Description/Function
Time Group 1-8	1. Automatic Mode 2. Manual Day Mode 3. Manual Night Mode 4. Manual Lunch Mode 5. Manual Break Mode 6. PBX Control Mode (Automatic Mode)	Assigns a specific Service Mode to the Time Group. There are 6 options available: 1. Automatic Mode—Operates according to the setting in the Time Service. 2. Manual Day Mode—Operates only in Day Mode. 3. Manual Night Mode—Operates only in Night Mode. 4. Manual Lunch Mode—Operates only in Lunch Mode. 5. Manual Break Mode—Operates only in Break Mode. 6. PBX Control Mode—Operation changes depending on PBX time period. Note Once the Service Mode has been changed, it is retained unless the System Manager or System Administrator changes it again, even after the power is cut and restored. PBX Control Mode is available only if DPT Integration is activated with a Panasonic KX-T series telephone system. If PBX Control Mode does not function after it has been selected, the VPS will operate in Automatic Mode.

In Automatic Mode, services have this order of priority:

Toll Saver > Holiday Service > Caller ID Call Routing > DID Call Routing > Trunk Service > Port Service

(Toll Saver has the highest priority.)

In Manual Modes (Day, Night, Lunch, or Break), services have this order of priority:

Caller ID Call Routing > DID Call Routing > Trunk Service > Port Service

(Toll Saver and Holiday Service are disregarded.)

Time Group Service-Time Service

Time Service is a timer function that selects the desired call handling method based upon time of day: Day, Night, Lunch and Break Services are available.

Night Service can be assigned within Day Service parameters; Night Service starts when Day Service ends, and ends when Day Service starts. There are 3 periods for Break Service:

Break 1 Service, Break 2 Service and Break 3 Service.

You can have different Time Service settings for each Time Group 1-8.

In each Time Service period, the parameters for Port Service, Trunk Group Service and Operator’s Parameters can be specified differently.

Note

Break Service and Lunch Service are only available when they are in Day Service period. If Break 3 Service is out of Day Service period, for example, Break 3 Service does not work.

To access the menu for Time Group Service-Time Service for the selected time group, follow the menu path as shown:

System Administration Top Menu-1-5-2-2-Time Group No.(1-8)

Time Service-Time Group (1-8)-Day Service

To access the menu for Day Service for the selected time group, follow the menu path as shown:

System Administration Top Menu-1-5-2-2-Time Group No.(1-8)-1

Table B-23

Parameter	Value Range (Default)	Description/Function
Mon (Start/End) Sun (Start/End)	1-12: h 00-59: min AM/PM: a.m./p.m. D: Day Mode N: Night Mode (9:00 AM-5:00 PM)	Specifies the "Start" and "End" times of the Day Service. Day Mode: Day Mode in effect around the clock (24 h) Night Mode: Night Mode in effect around the clock (24 h)

Time Service-Time Group (1-8)-Lunch Service

To access the menu for Lunch Service for the selected time group, follow the menu path as shown:

System Administration Top Menu-1-5-2-2-Time Group No.(1-8)-2

Table B-24

Parameter	Value Range (Default)	Description/Function
Mon (Start/End) Sun (Start/End)	1-12: h 00-59: min AM/PM: a.m./p.m. (None)	Specifies the "Start" and "End" times of the Lunch Service.

Time Service-Time Group (1-8)-Break Service

To access the menu for Break Service for the selected time group, follow the menu path as shown:

System Administration Top Menu-1-5-2-2-Time Group No.(1-8)-3

Table B-25

Parameter	Value Range (Default)	Description/Function
Mon Break 1 Service Break 2 Service Break 3 Service (Start/End) Sun Break 1 Service Break 2 Service Break 3 Service (Start/End)	1-12: h 00-59: min AM/PM: a.m./p.m. (None)	Specifies the "Start" and "End" times of the Break Service. Note When Break Service periods overlap Lunch Service period, Lunch Service has priority.

B6.3 Holiday Setting

You can program special settings for up to 20 Holiday Services. On the day(s) specified as holiday(s), settings in this parameter have priority over settings for Trunk Service, Port Service and Caller ID Call Routing.

When setting specific day(s) as holiday(s), you have the following 2 options:

- The first option is to specify a single day on which to enable the Holiday Service setting. For example, you can specify the New Year’s Day as a holiday.
- The second option is to specify a range of days to enable the Holiday Service setting on all days within the specified range. For example, you can specify the start and the end dates of your Christmas vacation.

Note

Holidays cannot overlap. For example, if you have set Dec. 22nd to Jan. 6th as holidays, you cannot set Jan. 1st as a holiday.

To provide a special message to callers on a holiday (for example, *"Today is New Year’s Day and our office is closed. If you wish to record a message, please press 1 now"*.), you can create a Custom Service menu. Use this setting to direct calls to this Custom Service on Jan. 1st. Use foreign languages where appropriate.

To access the menu for Holiday Setting, follow the menu path as shown:

System Administration Top Menu-1-5-3

Holiday Setting-Enter

To access the menu for Holiday Setting-Enter, follow the menu path as shown:

System Administration Top Menu-1-5-3-1-Holiday No.(1-20)

Table B-26

Parameter	Value Range (Default)	Description/Function
Name of Holiday	Up to 16 characters (None)	For reference. Any alphanumeric character, and [(space)], [-], [.] and ['] can be used.

Table B-26

Parameter	Value Range (Default)	Description/Function
Date	MM/DD-MM/DD or MM/DD (MM: Month DD: Day) (None)	Specifies the day or the range of days on which to enable Holiday Service setting. <ul style="list-style-type: none"> If you want to set a single day as a holiday, specify only one date. If you want to set a range of days as holidays, specify both the start and the end dates of the range. <p>Note Holidays cannot overlap.</p>
Retain Holiday	1. Yes 2. No (No)	Stores the Holiday Service setting for future use. If set to "Yes", the same setting will be activated automatically on the same day every year. If set to "No", the setting will be canceled automatically after the holiday is over.
Service	1. Voice Mail 2. Auto. Attn. 3. Interview 4. Custom (Auto. Attn.)	Specifies one of 4 incoming call services for the holiday. <p>Note When Interview Service is specified, one Subscriber's Interview Mailbox number should also be specified. When the Custom Service is specified, one of Custom Service numbers (1-100) should also be specified.</p>
Company Greeting No.	1-32 S: System Greeting N: None (None)	Specifies the Company Greeting to be played on the holiday. <p>The System Greeting is: <i>"Good Morning/Afternoon/Evening. Welcome to the Voice Processing System"</i>. (However, the Message Manager can change this.)</p>
Port Affected	Port No. (1-24)	Specifies the port number on which the Holiday Service setting is activated. The unspecified ports provide the usual incoming call service. <p>Note Pressing [(back space)] will clear the parameter.</p> <p>The maximum number of ports depends on the VPS model.</p>

Table B-26

Parameter	Value Range (Default)	Description/Function
Trunk Affected	Trunk No. (1-48)	Specifies the trunk (CO line) number on which the Holiday Service setting is activated. The unspecified trunks (CO lines) provide the usual incoming call service. Note Pressing [(back space)] will clear the parameter.

Holiday Setting-Delete

Cancels the Holiday Service Setting by specifying a holiday number (1-20).

To access the menu for Holiday Setting-Delete, follow the menu path as shown:

System Administration Top Menu-1-5-3-2

Holiday Setting-Listing

Displays all of the specified holiday names and dates.

To access the menu for Holiday Setting-Listing, follow the menu path as shown:

System Administration Top Menu-1-5-3-3

B6.4 Daylight Saving Time (DST)

Adjusts the internal clock of the VPS to the starting and ending date of daylight saving time.

To access the menu for Daylight Saving Time, follow the menu path as shown:

System Administration Top Menu-1-5-4

Table B-27

Parameter	Value Range (Default)	Description/Function
Start Date/ End Date	MM: Month DD: Day (None)	<p>Specifies the starting and ending dates of daylight saving time. The VPS advances 1 h on the starting date of daylight saving time, and restores the time on the ending date. Both the starting date and the ending date must be set. The same date cannot be used for both settings.</p> <p>WARNING</p> <p>Time Synchronization (see 7.2.4 Set Time (TIME)) overrides the DST setting of the VPS.</p>

Note

The VPS changes to and from DST at 2:00 AM. According to current U.S. guidelines, in most of the United States, DST begins at 2:00 AM on the first Sunday in April and ends at 2:00 AM on the last Sunday in October.

B6.5 Prompt Setting

This setting is required when Multilingual Service is enabled.

To access the menu for Prompt Setting, follow the menu path as shown:

System Administration Top Menu-1-5-5

Table B-28

Parameter	Value Range (Default)	Description/Function
System Prompt Selection Number	1-9 (None)	<p>Assigns a selection number (1-9) to each prompt. Callers use the numbers to select the desired language for their message prompts. This setting is required when either one or both of the following parameters are set to "Selective".</p> <p>Port Assignment—Incoming Call Service Prompt Authorization of External Message Delivery—Prompt Mode</p> <p>Example: <i>For service in English, press (7).</i> <i>For service in French, press (8).</i> <i>For service in Chinese, press (9).</i></p> <p>The Message Manager is responsible for recording this Multilingual Selection Menu.</p> <p>Note</p> <p>The Prompt Selection Number should not match the first digit of any mailbox number, because mailbox/extension access is possible during and after the Multilingual Selection Menu.</p>
User 1 Prompt Selection Number		
User 2 Prompt Selection Number		
Position of "AM/PM" in Time Stamp for User 1 Prompt	1. Before 2. After 3. 24-h (After)	<p>This parameter setting is functional only when User 1 or User 2 Prompts are in use. This parameter specifies the following:</p> <p>1. Before—the VPS announces "AM/PM" before the time (e.g., <i>P.M. 3:42</i>).</p> <p>2. After—The VPS announces "AM/PM" after the time (e.g., <i>3:42 P.M.</i>).</p> <p>3. 24-h—the VPS announces the time in 24-h format (e.g., <i>15:42</i>).</p> <p>Note</p> <p>When System Prompts are in use, the parameter is set to "After".</p>
Position of "AM/PM" in Time Stamp for User 2 Prompt	1. Before 2. After 3. 24-h (24-h)	

B6.6 System Caller Name Announcement

Up to 120 Caller ID numbers can be assigned to announce prerecorded Caller ID caller names when extension users listen to messages from the assigned numbers left in their mailbox. Extension users can also hear caller names when the VPS forwards calls from the assigned numbers to them (Caller ID Screening). The recorded caller names will also play when the callers use the Intercom Paging features; the recorded names will be added to the end of the page.

The Caller ID Screening feature is enabled or disabled in the COS (Class of Service) settings. This feature is also enabled by selecting "Call Screening" in 4.1 Call Transfer Status in the Subscriber's Guide.

The Intercom Paging feature is enabled by selecting "Intercom Paging" in 4.1 Call Transfer Status, and/or in 4.3 Incomplete Call Handling Status in the Subscriber's Guide.

The Message Manager is responsible for recording System Caller Names.

To access the menu for System Caller Name Announcement, follow the menu path as shown:

System Administration Top Menu-1-5-6

System Caller Name Announcement-Enter

To access the menu for System Caller Name Announcement-Enter, follow the menu path as shown:

System Administration Top Menu-1-5-6-1-Caller ID List No.(1-120)

Table B-29

Parameter	Value Range (Default)	Description/Function
Caller ID No.	Up to 20 digits consisting of 1-9, 0 (None)	Assigns the telephone number for which the VPS announces prerecorded caller name to extension users.
Description	Up to 20 characters (None)	Enters a name and/or description of the Caller ID number. Any ASCII character (except \) can be used.

System Caller Name Announcement-Delete

Deletes specified Caller ID List numbers from the list.

To access the menu for System Caller Name Announcement-Delete, follow the menu path as shown:

System Administration Top Menu-1-5-6-2-Caller ID List No.(1-120)

System Caller Name Announcement-Listing

Displays all Caller ID List numbers.

To access the menu for System Caller Name Announcement-Listing, follow the menu path as shown:

System Administration Top Menu-1-5-6-3

B6.7 System Security

This setting is required for improving the system security.

To access the menu for System Security, follow the menu path as shown:

System Administration Top Menu-1-5-7

Table B-30

Parameter	Value Range (Default)	Description/Function
System Manager Access from Telephone	1: Disable 2: Enable (Disable)	<p>Enables/disables access to the VPS from the System Manager's telephone.</p> <p>Note</p> <p>The System Administrator will be asked to set a System Manager password if both of the following conditions are met:</p> <ul style="list-style-type: none"> • The System Administrator changes this parameter from "Disable" to "Enable". • The System Manager password has not been set previously. <p>The password must be entered twice for verification.</p>

Table B-30

Parameter	Value Range (Default)	Description/Function
Message Manager Access from Telephone	1: Disable 2: Enable (Disable)	<p>Enables/disables access to the VPS from the Message Manager's telephone.</p> <p>Note</p> <p>The System Administrator will be asked to set a Message Manager password if both of the following conditions are met:</p> <ul style="list-style-type: none"> • The System Administrator changes this parameter from "Disable" to "Enable". • The Message Manager password has not been set previously. <p>The password must be entered twice for verification.</p>
Default Password for Subscriber	1: No 2: Yes (No)	<p>Defines whether or not the VPS sets a default password to Subscribers' Mailboxes when they are created. The default password depends on the setting in the following "Default Password Format" parameter.</p> <p>Note</p> <p>Even if this parameter is changed from "No" to "Yes", a new default password will not be set to already-created mailboxes. Pre-assigned passwords remain valid.</p> <p>The password can be changed in the following ways:</p> <ul style="list-style-type: none"> • Subscribers can change or clear the default password for their mailboxes within Subscriber Service. • The System Administrator or the System Manager can reset the password. After the password is reset, the conditions will be as follows: <Subscribers' Mailboxes> If this parameter is set to "Yes", the password will be initialized to the default password. If this parameter is set to "No", the password will be cleared. <Managers' Mailboxes> The password is initialized to "No password". When the System Manager's password is reset, the "System Manager Access from Telephone" parameter will automatically change to "Disable". When the Message Manager's password is reset, the "Message Manager Access from Telephone" parameter will automatically change to "Disable".

Table B-30

Parameter	Value Range (Default)	Description/Function
Default Password Format	1: 1+Mailbox No. 2: 2+Mailbox No. 3: 3+Mailbox No. 4: 4+Mailbox No. 5: 5+Mailbox No. 6: 6+Mailbox No. 7: 7+Mailbox No. 8: 8+Mailbox No. 9: 9+Mailbox No. 0: Mailbox No. (Mailbox No.)	Defines the password format. This parameter is effective only when the previous "Default Password for Subscriber" parameter is set to "Yes". Example: Default Password Format = 5 + Mailbox No. New Mailbox No. = 123 New Mailbox Default Password = 5123 The new mailbox's password is automatically set to the default.

B6.8 Other Parameters

To access the menu for Other Parameters, follow the menu path as shown:

System Administration Top Menu-1-5-8

Other Parameters-Extension Numbering Plan

Specifies the extension numbers of the PBX so that the VPS is able to recognize the dialed extension as valid. This setting promotes the call handling of the Automated Attendant Service. We recommend that this parameter be set for better integration with the PBX.

To access the menu for Extension Numbering Plan, follow the menu path as shown:

System Administration Top Menu-1-5-8-1

Table B-31

Parameter	Value Range (Default)	Description/Function
Numbering Plan 1-16	2-5 digits consisting of 0-9, X (Numbering Plan 1: 1XX [KX-TVS125/225] or 1XXX [KX-TVS325]; Numbering Plan 2-16: None)	<p>Specifies the first 1 or 2 digits of the PBX extension numbers. You can add up to 16 entries to the list. Each entry can contain 2-5 digits "0-9", and a letter "X" which matches any digit. Extension numbers cannot begin with "0".</p> <p>Examples:</p> <p>a) If valid PBX extension numbers are to be specified 1001 through 1064 and 2001 through 2064, specify the numbers as follows:</p> <p>1XXX: Indicates any 4-digit extension number starting with "1".</p> <p>2XXX: Indicates any 4-digit extension number starting with "2".</p> <p>b) If valid PBX extension numbers are to be specified 400 through 450 and 3300 through 3399, specify the numbers as follows:</p> <p>4XX: Indicates any 3-digit extension number starting with "4".</p> <p>33XX: Indicates any 4-digit extension starting with "33".</p> <p>Note</p> <p>Auto Configuration will set this parameter automatically.</p> <p>The Automated Attendant will dial any 2-5 digit PBX extension number (except numbers beginning with "0") whether valid or not. If the dialed number is included in the numbering plan, the Automated Attendant will immediately send it to the PBX without waiting for further input. If not, the Automated Attendant will wait until the dialed number is recognized as an extension number, the internal inter-digit timer expires, or the caller dials 5 digits.</p> <p>If the number for an outgoing call is not found on the Numbering Plan, the VPS will consider it an outside number. The VPS will then attempt to dial it using the "Outgoing Call Setup Sequence".</p>

Other Parameters-Dialing Parameter

To access the menu for Dialing Parameter, follow the menu path as shown:

System Administration Top Menu-1-5-8-2

Table B-32

Parameter	Value Range (Default)	Description/Function
Number of Digits to Access Outside Line	0-8 digits (1)	<p>Specifies the number of digits necessary to access an outside (CO) line.</p> <p>Example: If the PBX requires callers to dial "9" to access an outside (CO) line, this parameter should be set as "1". This enables the system to recognize that an outgoing call setup sequence is completed once the initial "9" has been dialed (9-123-4567). The full sequence is therefore: 9-(outgoing call setup sequence)-123-4567.</p> <p>The VPS can discriminate between local and long distance calls and can report outgoing calls and calling times for billing purposes on periodic port usage reports.</p>
Call Transfer No Answer Time	10-60 s (20)	<p>Specifies the length of time that the VPS must wait before retrieving the transferred call when there is no answer at the destination extension.</p> <p>Note Make sure that the duration of Call Transfer No Answer Time is longer than the duration of Call Forwarding No Answer Time at the PBX. Otherwise, the PBX may forward the call (transferred by the VPS) immediately to its destination without leaving enough time to answer the call.</p>
Outgoing Call No Answer Time	10-90 s (30)	Specifies the length of time that the VPS must wait before concluding that there is no answer at the outside number called.
Pause Time	1-9 s (2)	Specifies the pause time between dialed digits.

Table B-32

Parameter	Value Range (Default)	Description/Function
Outgoing Call Setup Sequence	Up to 12 digits consisting of 0-9, *, #, F, R, S, T, W (T)	Specifies the sequence of codes used by the VPS when calling a CO line. You can set up to 12 digits. The default value is "T". "T" indicates that the system will dial the telephone number only after detecting a dial tone. Example: 9W = (9) - 1-s wait - dial telephone number. "9" is the CO line access number. F: Hook Flash R: Ringback Tone Detection S: Silence Detection T: Dial Tone Detection W: Wait for 1 s 1-9, 0, *, #: Dial Codes

Other Parameters-Message Waiting Notification

Controls the handling of message waiting notification calls.

To access the menu for Message Waiting Notification Parameter, follow the menu path as shown:

System Administration Top Menu-1-5-8-3

Table B-33

Parameter	Value Range (Default)	Description/Function
Outgoing Call Ports	Port No. (1-24)	Specifies the port numbers used for the Message Waiting Notification Device feature. The VPS makes outgoing calls using the port specified in this parameter. At least 1 port must be specified. Note The maximum number of ports depends on the VPS model.

Table B-33

Parameter	Value Range (Default)	Description/Function
Message Waiting Lamp Ports	Port No. (1-24)	<p>Specifies the port numbers used for the Message Waiting Notification Lamp feature.</p> <p>The VPS turns on the Message Waiting Lamp of the extension using the port specified in this parameter. At least 1 port must be specified.</p> <p>Note</p> <p>The maximum number of ports depends on the VPS model.</p>
Message Waiting Lamp for Every Message	1. No 2. Yes (Yes)	<p>If set to "Yes", the VPS will turn on the Message Waiting Lamp of the extension each time a new message is recorded in the mailbox. This will occur even if the Message Waiting Lamp was not turned off from a previous message. This setting is useful when the first attempt is unsuccessful.</p> <p>If set to "No", the VPS will turn on the Message Waiting Lamp for the first message only. The VPS will not turn on the lamp for subsequent messages until the subscriber has accessed the VPS to retrieve the messages stored there.</p>
Max. Digits for Callback No.	1-48 digits (20)	Specifies the maximum number of digits the caller can enter as a callback number. This number will display on beepers if the "Beeper Callback No. Entry Mode" is enabled.
Callback No. Entry Interdigit Time-Out	1-10 s (5)	Sets the maximum allowable time between each digit on Beeper Callback No. Entry. If the caller does not enter any digits within the specified time, the VPS will not accept entry of any additional digits.
System Callback No.	Up to 32 digits (None)	<p>Specifies a telephone number that will display on the subscriber's beeper as a callback number. The callback number entry mode "X" must be included in the telephone number.</p> <p>Note</p> <p>If "Beeper Callback No. Entry Mode" is enabled through COS, the callback number entered by the caller will display on the destination beeper. However, if the caller fails to enter a callback number, the System Callback No. will display instead.</p>

Other Parameters-External Message Delivery

Controls the handling of External Message Delivery calls.

To access the menu for External Message Delivery, follow the menu path as shown:

System Administration Top Menu-1-5-8-4

Table B-34

Parameter	Value Range (Default)	Description/Function
Retry Times	0-9 times (3)	Specifies the number of times to attempt an external message delivery call when the destination is busy or if there is no answer.
Busy Delay	1-60 min (3)	Specifies the length of time in minutes the VPS must wait after a busy condition is received before trying to deliver the message again.
No Answer Delay	60-120 min (60)	Specifies the length of time in minutes the VPS is to wait after a no answer condition is received before trying to deliver the message again.
Outgoing Call Ports	Port No. (1-24)	Specifies the port numbers used for the External Message Delivery feature. Note The maximum number of ports depends on the VPS model.
Message Length	1-6 min (3)	Specifies the allowable message length of external delivery messages that the subscriber can record.
Max. Messages for Mailboxes	1-100 msgs (3)	Specifies the maximum number of external delivery messages that can be stored in 1 mailbox.
System External Message Delivery Duration Time	1-9 min (3)	Specifies the maximum telephone connect time allowed for an external message delivery call to prevent excessive telephone charges. Time begins counting when the destination number answers the call. The VPS terminates the call when it exceeds the specified length of time. However, the VPS does not terminate a call until the whole message is played even though the specified time expires.
Company's Telephone No.	Up to 32 digits (None)	Specifies the Company's Telephone Number. When the recipient has failed to retrieve the sender's message because of incorrect password entries, the VPS announces the Company's Telephone Number for him to call in order to retrieve it.

Other Parameters-Call Hold

To access the menu for Call Hold, follow the menu path as shown:

System Administration Top Menu-1-5-8-5

Table B-35

Parameter	Value Range (Default)	Description/Function
Call Hold Mode	1. Disable 2. Enable (Enable)	If set to "Enable", the VPS gives callers the option of either holding for a specific extension or selecting one of several Incomplete Call Handling service options. While on hold, the VPS periodically gives callers the choice to either continue to hold or select one of the Incomplete Call Handling service options. If set to "Disable", the VPS immediately offers callers the Incomplete Call Handling service.
Call Queuing Announcement Mode	1. Disable 2. Enable (Enable)	If set to "Enable", callers on hold are informed of their current position in the call hold queue. Example: <i>"One other person is waiting to connect".</i>
Call Retrieval Announcement Timing	1-30 s (2)	Specifies the interval between the voice guidance message that asks whether or not calls are to be retrieved during call holding. Example: <i>"To cancel holding, press 2 now. Otherwise, I'll try your party again".</i>
Redialing Cancel Timing	1. 15 s 2. 30 s 3. 45 s 4. 60 s (30)	Specifies the interval between the voice guidance messages that ask if continuous redials are to be attempted during call holding. Example: <i>"To continue holding, press 1. Otherwise, press 2".</i>

Other Parameters-Rotary Telephone Service

Specifies how to treat callers who are calling from rotary telephones (unable to input touchtone signals) or who are unable to properly respond to VPS guidance.

To access the menu for Rotary Telephone Service, follow the menu path as shown:

System Administration Top Menu-1-5-8-6

Table B-36

Parameter	Value Range (Default)	Description/Function
Rotary Telephone Call Coverage (Day/Night/Lunch/Break)	G: G. D. M O: Operator E: Extn. M: Mbx. (G. D. M.)	Defines how the VPS treats calls received from rotary telephones or calls from callers that are unfamiliar with the VPS operation in the Voice Mail Service. G.D.M: General Delivery Mailbox. O: Operator E: Extension (Enter "E" followed by an extension number.) M: Mailbox (Enter "M" followed by a mailbox number.)

Other Parameters-Intercom Paging Parameter

Intercom Paging is a PBX feature that makes it possible to page the caller's party through telephone speakers. To utilize this feature, the PBX must have the Intercom Paging feature available and the VPS must be properly programmed. This feature is available for DPT Integration mode only.

To access the menu for Intercom Paging Parameter, follow the menu path as shown:

System Administration Top Menu-1-5-8-7

Table B-37

Parameter	Value Range (Default)	Description/Function
Intercom Paging Sequence	Up to 12 digits consisting of 0-9, *, # and special codes (FXW)	Specifies the intercom paging sequence required by the PBX. This can be programmed using up to 12 of the following 8 letters and 12 dial codes. D: Disconnecting F: Hook Flash R: Ringback Tone Detection S: Silence Detection T: Dial Tone Detection W: Wait for 1 s X: Pager Dialing A: Answer 1-9, 0, *, #: Dial Codes
Release for Intercom Paging	Up to 12 digits consisting of 0-9, *, # and special codes (FW)	Specifies the intercom paging release code required by the PBX. This can be programmed using up to 12 of the 8 letters and 12 dial codes as specified above.

Table B-37

Parameter	Value Range (Default)	Description/Function
No Answer Time for Intercom Paging	1-30 s (5)	Specifies the length of time (in seconds) the VPS must wait before concluding Intercom Paging when there is no answer. The VPS will return to the caller if the paged party does not respond before this timer expires.
Announcement Repeat Cycle	1-3 times (1)	Specifies the number of times to announce the intercom page. Example: <i>"I have a call for (mailbox owner's name)".</i>
Intercom Paging Retry	1-10 times (2)	Specifies the number of times to retry paging when the paging destination is busy or if there is no answer. Note This setting applies only when the subscriber has enabled "Intercom Paging" in Incomplete Call Handling Status.
Paging Code for Group 1-16 Paging Code for All Groups	Up to 12 digits consisting of 0-9, *, # for each group (KX-TVS125/ KX-TVS225: Group 1-8: 331-338; All Groups [Group 17]: 33*) or (KX-TVS325: Group 1-16: 3301-3316; All Groups [Group 17]: 33*)	Specifies the intercom paging access code required by the PBX. Note The Intercom Paging Group Number available for each subscriber is determined on a COS-by-COS basis.

Other Parameters-Fax Management

You can program the VPS to automatically forward incoming fax calls to a fax extension. You can specify a maximum of 2 fax extensions as the destination for the Automatic Fax Transfer. If the main fax extension is not available to receive a fax, the VPS will forward the fax transmission to the alternate fax extension.

To access the menu for Fax Management, follow the menu path as shown:

System Administration Top Menu-1-5-8-8

Table B-38

Parameter	Value Range (Default)	Description/Function
Automatic Transfer of Incoming Fax Call	1: Disable 2: Enable (Disable)	Enables or disables the Automatic Transfer of Incoming Fax Call Service. Note Automatic detection works for only the first 30 s.
Main Fax Extension No.	2-5 digits (None)	Specifies the main fax extension number.
Alternate Fax Extension No.	2-5 digits (None)	Specifies the alternate fax extension number. When the main fax extension is busy or does not answer within the specified "Fax No Answer Time", the VPS forwards the fax call to the alternate fax extension.
Fax No Answer Time	5-60 s (10)	Specifies the length of time (in seconds) the VPS must wait before taking other action when there is no answer at either fax extension. Note This timer applies to the fax call that has been transferred to the main or alternate fax extension.
Fax Manager Mailbox No.	2-5 digits (None)	Specifies the Fax Manager Mailbox Number. The VPS will notify the fax manager of the status of fax calls depending upon the settings of the "Fax No Answer Coverage Mode" and "Fax Notification Mode" parameters.
Fax No Answer Coverage Mode	1. No 2. Mbx 3. Ext (No)	If set to "Mbx", the VPS will leave the number of unanswered fax calls in the Fax Manager's mailbox. Example: <i>"The FAX transfer situation is as follows. One attempt was no answer"</i> . 1. If set to "Ext", the VPS will call the Fax Manager's extension to specify the number of unanswered fax calls received. 2. If set to "Mbx", the VPS will leave the number of unanswered fax calls in the Fax Manager's mailbox. 3. If set to "No", the VPS will take no action concerning unanswered fax calls.

Table B-38

Parameter	Value Range (Default)	Description/Function
Fax Notification Mode	1. No 2. Mbx 3. Ext (No)	If set to "Mbx", the VPS will leave the number of successfully received fax calls in the Fax Manager's mailbox. Example: <i>"You have 1 FAX message"</i> . 1. If set to "Ext", after a fax extension successfully receives a fax call, the VPS will automatically call the Fax Manager's extension and play a voice prompt: <i>"You have 1 FAX message"</i> . The VPS will also leave the total number of received fax calls in the Fax Manager's mailbox. 2. If set to "No", the VPS will not take any action concerning successfully received fax calls.

Other Parameters-Disconnect Parameter

To access the menu for Disconnect Parameter, follow the menu path as shown:

System Administration Top Menu-1-5-8-9

Table B-39

Parameter	Value Range (Default)	Description/Function
Maximum Silence Time	5-60 s (10)	When silence is detected for this amount of time in seconds, the VPS disconnects the call.

B7 SYSTEM ADMINISTRATION—HARDWARE SETTINGS

For System Administration (system setup, mailbox setup, and system diagnosis), an RS-232C terminal must be connected to the serial interface of the VPS.

To access the menu for Hardware Setting, follow the menu path as shown:

System Administration Top Menu-1-6

B7.1 RS-232C Parameters

To access the menu for RS-232C Parameter, follow the menu path as shown:

System Administration Top Menu-1-6-1

Table B-40

Parameter	Value Range (Default)	Description/Function
Baud Rate	1. 300 bps 2. 600 bps 3. 1200 bps 4. 2400 bps 5. 4800 bps 6. 9600 bps 7. 19200 bps 8. 38400 bps (9600)	Specifies the speed at which the data is transferred in bits per second.
Word Bit Length	1. 7 bits 2. 8 bits (8 bits)	Defines the number of bits in each byte or character.
Parity	1. None 2. Odd 3. Even (None)	Specifies the parity to use for error detection.
Stop Bit Length	1. 1 bit 2. 2 bits (1 bit)	Specifies the number of bits used to signify the end of the byte.

B7.2 Port Setting

To access the menu for Port Setting, follow the menu path as shown:

System Administration Top Menu-1-6-2

Port Setting Menu

To access the menu Port Setting Menu for the selected port, follow the menu path as shown:

System Administration Top Menu-1-6-2-Port No.(1-24)

Note

The maximum number of ports depends on the VPS model.

Table B-41

Parameter	Value Range (Default)	Description/Function
Flash Time	1. 100 ms 2. 300 ms 3. 600 ms 4. 900 ms (600)	Specifies the length of time the hook switch must be pressed before the PBX will recognize it as a flash hook signal. See the PBX manual to determine the correct value.
CPC Signal	1. None 2. 6.5 ms 3. 150 ms 4. 300 ms 5. 450 ms 6. 600 ms (None)	Specifies the minimum time necessary to detect an interruption in the CPC (Calling Party Control) signal received from the PBX. The VPS is able to determine that the line has been disconnected when it detects an interruption of the CPC signal.
Disconnect Time	1-8 s (2)	Specifies the length of time the line will temporarily be unavailable after a call has ended.
Dial Mode	1. DTMF 2. Pulse 10 pps 3. Pulse 20 pps (DTMF)	Specifies the dial mode for DTMF (touchtone) or Pulse. If Pulse is specified, pulse speed (10/20 pps) must be selected. Note This setting only affects outward dialing from the VPS. The VPS can only receive DTMF (touchtone) signals.

B7.3 PBX Interface Parameters

Three separate parameters are used to program the VPS for optimal signaling and performance with the PBX.

To access the menu for PBX Interface Parameters, follow the menu path as shown:

System Administration Top Menu-1-6-3

Dialing Parameters

These parameters specify how the VPS will initiate and control call transfers, setup outgoing calls, and control message waiting lamps on extensions. The procedure for verifying the correct code sequences for non-Panasonic KX-T series telephone systems is to manually execute the sequences from a single line telephone (SLT) with the PBX.

To access the menu for Dialing Parameters, follow the menu path as shown:

System Administration Top Menu-1-6-3-1

Table B-42

Parameter	Value Range (Default)	Description/Function
PBX Type	1. Other Manufacturers 2. KXT Series 1. T308 2. T616 3. T1232/TA624 4. T96 5. T336 6. TD816 7. TD1232/TA1232 8. TD500 9. TD308 A. TDA/TAW series (KX-TVS125/KX-TVS225: TD1232; KX-TVS325: TD500)	Specifies the type of PBX connected to the VPS. In the case of a Panasonic KX-T series telephone system, the model number should also be specified. Note The Dialing Parameters are set automatically to each PBX default value after selecting the PBX type.

Table B-43

PBX Type	Other Manufacturers	KX-T series										
		T308/T616	T1232/TA624	T96	T336	TD816/ TD1232/ TA1232/TD308		TD500		TDA/TAW series		
Integration Mode	None	None	None	None	None	None	None	*DPT	None	*DPT	None	*DPT
	Inband		Inband	Inband	Inband	Inband	Inband		Inband			
Operator Transfer Sequence	FXA	FTXA	FTXA	FTXA	FTXA	FTXA	FXA	FTXA	FXA	FTXA	FXA	
Extension Transfer Sequence	FXA	FTXA	FTXA	FTXA	FTXA	FTXA	FXA	FTXA	FXA	FTXA	FXA	
Alternate Extension Transfer Sequence	FXA	FTXA	FTXA	FTXA	FTXA	FTXA	FXA	FTXA	FXA	FTXA	FXA	
Reconnect Sequence on Busy	FWW	FWW	FWW	FWW	FWW	FWW	F	FWW	F	FWW	F	
Reconnect Sequence on No-Answer	FWW	FWW	FWW	FWW	FWW	FWW	F	FWW	F	FWW	F	
Reconnect Sequence on Refused Call	FWW	FWW	FWW	FWW	FWW	FWW	F	FWW	F	FWW	F	
Light-On Sequence for Message Waiting Lamp	None	N/A	T701X#	T#91X	T*9X	T701X	—	T701X	—	T*701X	—	
Light-Off Sequence for Message Waiting Lamp	None	N/A	T702X#	T#90X	T#9X	T700X	—	T700X	—	T*700X	—	
Call Waiting Sequence	None	N/A	1	N/A	N/A	1	1	1	1	1	1	

Table B-43

PBX Type	Other Manufacturers	KX-T series									
		T308/T616	T1232/TA624	T96	T336	TD816/ TD1232/ TA1232/TD308		TD500		TDA/TAW series	
Release Sequence for Call Waiting	None	N/A	F	N/A	N/A	F	F	F	F	F	F

* When your KX-T series telephone system is in DPT Integration mode.

N/A Not available

— Not needed

Table B-44

Parameter	Value Range (Default)	Description/Function
Integration Mode	1. None 2. Inband 3. DPT (DPT)	Specifies the method of integrating the VPS with the PBX. 1. None—Both PBX and VPS work independently, without accessing information concerning the status of the other. 2. Inband—The PBX sends touchtone codes to the VPS to indicate the state of the call (busy, answered, disconnect, etc.). Inband Integration improves the VPS performance because call state recognition is faster than with standard call progress tone detection. The PBX code for each call state must be set in the Inband Signaling Parameters. If PBX type is set to a KX-T series telephone system, the Inband Signaling Parameters will automatically default to the proper codes. This is available with any of the following Panasonic KX-T series telephone systems: T1232, TA624, T96, T336, TD816, TD1232, TA1232, TD500, TD308, and TDA/TAW series. 3. DPT—The VPS communicates with the PBX via the DPT interface. This is available with any of the following Panasonic KX-T series telephone systems: TD816, TD1232, TA1232, TD500, TD308, and TDA/TAW series.

To program the following 10 Parameters in the next table, use the Special Commands and Dial Codes listed below. You can set up to 12 digits for each parameter.

- D: Disconnecting
- F: Hook Flash
- R: Ringback Tone Detection

- S: Silence Detection
- T: Dial Tone Detection
- W: Wait for 1 s
- X: Extension dialing
- A: Answer
- 1-9, 0, *, #: Dial Codes

Table B-45

Parameter	Value Range (Default)	Description/Function
Operator Transfer Sequence	(FXA)	The VPS performs this sequence when transferring calls to the operator's extension.
Extension Transfer Sequence	(FXA)	The VPS performs this sequence when transferring calls to any extension except the operator's.
Alternate Extension Transfer Sequence	(FXA)	The VPS performs this sequence when transferring calls to extensions in the Alternate Extension Group.
Reconnect Sequence on Busy	(F)	If an extension is busy, this sequence allows the VPS to reconnect to the caller.
Reconnect Sequence on No Answer	(F)	If the extension does not answer, this sequence allows the VPS to reconnect with the caller.
Reconnect Sequence on Refuse Call	(F)	The VPS performs this sequence to retrieve a call placed on hold after the extension (in the Call Screening mode) has refused to accept it.
Light-On Sequence for Message Waiting Lamp	(None)	This is the dialing sequence that the VPS must perform to enable the Message Waiting Lamp at an extension.
Light-Off Sequence for Message Waiting Lamp	(None)	This is the dialing sequence that the VPS must perform to disable the Message Waiting Lamp at an extension.
Call Waiting Sequence	(1)	The VPS carries out this sequence when performing call waiting if the extension being called is busy.

Table B-45

Parameter	Value Range (Default)	Description/Function
Release Sequence for Call Waiting	(F)	The VPS performs this sequence to release call waiting.

Inband Signaling Parameters

Use these parameters if the PBX sends touchtones to the VPS to indicate the state of a call (busy, answered, disconnected, etc.). The integration mode must be set to "Inband". If PBX type is set to a KX-T series telephone system, the Inband Signaling parameters will automatically default to the proper codes.

To access the menu for Inband Signaling Parameters, follow the menu path as shown:

System Administration Top Menu-1-6-3-2

The following parameters can be programmed using "0-9", "×", "#", and "A-D".

Table B-46

Parameter	Value Range (Default)	Description/Function
Ringback	(1)	Indicates "Ringback Tone". Sent to the VPS when the extension dialed is ringing.
Busy	(2)	Indicates "Busy Tone". Sent to the VPS when the extension dialed is busy.
Reorder	(3)	Indicates "Reorder Tone". Sent to the VPS when an invalid extension number is dialed or when inadvertently connected to another VPS.
DND	(4)	Indicates "Do Not Disturb Tone". Sent to the VPS if the dialed extension has the Do Not Disturb feature enabled.
Answer	(5)	Sent to the VPS when the called extension answers the call.
Forward to VM Ringing	(6)	Sent to the VPS if the called extension is forwarded to a voice mail port and that voice mail port is available to accept the call.
Forward to VM Busy	(7)	Sent to the VPS if the called extension is forwarded to a voice mail port and that voice mail port is not available to accept the call.
Forward to Other Extension	(8)	Sent to the VPS if the called extension is forwarded to another, non-Voice Mail extension.

Table B-46

Parameter	Value Range (Default)	Description/Function
Confirmation	(9)	Sent to the VPS when it successfully dialed a Message Waiting Lamp On or Message Waiting Lamp Off Code.
Disconnect	(#9)	Sent to the VPS when the other party goes "on-hook".

Note

Default values in the above table vary depending on the settings of "PBX type" and "Inband Integration" (PBX Interface Parameters).

Table B-47

Parameter	Other Manufacturers	KX-T series						
		T308/T616	T1232/TA624	T96	T336	TD816/TD1232/TA1232/TD308	TD500	TDA/TAW series
Ringback	N/A	N/A	1	A1	A1	1	1	1
Busy	N/A	N/A	2	B1	B1	2	2	2
Reorder	N/A	N/A	3	B2	B2	3	3	3
DND	N/A	N/A	4	B3	B3	4	4	4
Answer	N/A	N/A	5	A2	A2	5	5	5
Forward to VM Ringing	N/A	N/A	6	C1	C1	6	6	6
Forward to VM Busy	N/A	N/A	7	C2	C2	7	7	7
Forward to Other Extension	N/A	N/A	8	C3	C3	8	8	8
Confirmation	N/A	N/A	9	D1	D1	9	9	9
Disconnect	N/A	N/A	#9	DD	DD	#9	#9	#9

N/A: Not available

Digit Translation Table Parameters

Use the Digit Translation Table to translate the Follow On ID Signal from the PBX into the proper codes for the VPS. This translation table is only effective for the incoming signal.

To access the menu for Digit Translation Table Parameters, follow the menu path as shown:

System Administration Top Menu-1-6-3-3

Digit Translation Table Parameters-Inter-Digit Timeout

To access the menu for Inter-Digit Timeout, follow the menu path as shown:

System Administration Top Menu-1-6-3-3-1

Table B-48

Parameter	Value Range (Default)	Description/Function
Inter-Digit Timeout	1-4 s (1)	Defines the incoming signal interval (Follow on ID). The Digit Translation Table is translated by a series of signals received within the specified time period.

Digit Translation Table Parameters-Input/Output

To access the menu for Input/Output, follow the menu path as shown:

System Administration Top Menu-1-6-3-3-2

Table B-49

Parameter		Value Range (Default)	Description/Function
Table 1-8	Input digit	Up to 8 digits consisting of 0-9, *, #, A-D, S, K (None)	Do not assign more than 1 code to an incoming signal. If this occurs, the system will take the first assignment. Note S: Skip (ignore) the code. K: Keep the code as it is. In each table, the number of "K" used for the Input digit must be the same as the one used for the Output digit.
	Output digit		

Transfer to Outside Parameters

These parameters specify how the VPS will transfer calls to outside lines from the following services: Custom Service, Call Transfer Service, Personal Custom Service, Caller ID Callback.

To access the menu for Transfer to Outside Parameters, follow the menu path as shown:

System Administration Top Menu-1-6-3-4

Transfer to Outside Parameters-Outside Transfer Sequence

To access the menu for Outside Transfer Sequence, follow the menu path as shown:

System Administration Top Menu-1-6-3-4-1

Table B-50

Parameter	Value Range (Default)	Description/Function
Call Transfer to Outside Sequence	Up to 12 digits consisting of 0-9, *, #, D, F, R, T, S, W, A, N (APT/DPT Integration: FND, other Integration: FTND)	Specifies the sequence the VPS uses to transfer calls to outside lines. Note The default setting (FND/FTND) includes the sequence code "D" (Disconnect), which executes a "blind" transfer. Removing "D" from the sequence results in a "screened" transfer, which is only supported with the KX-TD500 (V4M or higher). Therefore, please do not remove "D" from the sequence unless your PBX is the KX-TD500 (V4M or higher).
Call Transfer to Outside Reconnect Sequence on Busy	Up to 12 digits consisting of 0-9, *, #, D, F, R, T, S, W, A, N (APT/DPT Integration: F, other Integration: FWW)	Specifies the sequence the VPS uses to reconnect the line when the transferred party is busy.

Table B-50

Parameter	Value Range (Default)	Description/Function
Call Transfer to Outside Reconnect Sequence on No Answer	Up to 12 digits consisting of 0-9, *, #, D, F, R, T, S, W, A, N (APT/DPT Integration: F, other Integration: FWW)	Specifies the sequence the VPS uses to reconnect the line when the transferred party does not answer.
EFA Transfer Sequence	Up to 12 digits consisting of 0-9, *, #, D, F, R, T, S, W, A, N (F6TN)	Specifies the sequence the VPS uses to transfer calls to outside lines using EFA (External Feature Access). Note The default value is only activated when the VPS is connected to a default PBX (KX-TD1232/KX-TD500/KX-TA624). For other PBX types, the default value differs depending on the EFA Transfer Sequence specified in the PBX. For example, when the PBX Type is changed to a KX-TDA/KX-TAW series PBX, the default value becomes "F*60TN".
EFA Transfer Reconnect Sequence on Busy	Up to 12 digits consisting of 0-9, *, #, D, F, R, T, S, W, A, N (F6)	Specifies the sequence the VPS uses to reconnect the line when the party transferred with EFA (External Feature Access) is busy. Note The default value is only activated when the VPS is connected to a default PBX (KX-TD1232/KX-TD500/KX-TA624). For other PBX types, the default value differs depending on the EFA Transfer Sequence specified in the PBX. For example, when the PBX Type is changed to a KX-TDA/KX-TAW series PBX, the default value becomes "F*60".
EFA Transfer Reconnect Sequence on No Answer	Up to 12 digits consisting of 0-9, *, #, D, F, R, T, S, W, A, N (F6)	Specifies the sequence the VPS uses to reconnect the line when the party transferred with EFA (External Feature Access) does not answer. Note The default value is only activated when the VPS is connected to a default PBX (KX-TD1232/KX-TD500/KX-TA624). For other PBX types, the default value differs depending on the EFA Transfer Sequence specified in the PBX. For example, when the PBX Type is changed to a KX-TDA/KX-TAW series PBX, the default value becomes "F*60".

Table B-50

Parameter	Value Range (Default)	Description/Function
Outside Transfer Answer Mode	1. Analyze 2. Guidance (Guidance)	Specifies the answering method the VPS uses to detect whether the destination party has answered the transferred outside call. 1. Analyze—the VPS monitors the status of the outside line, recognizes that the destination party goes off-hook, and connects the line. 2. Guidance—the VPS plays the following guidance before connecting the line to the destination party: "You have a call. To answer the call, press 1. Otherwise, press 2 and hang up." If the destination party presses "1", he will be able to answer the transferred outside call. The VPS continues playing this guidance for the time specified in the Outgoing Call No Answer Time in Table B-32. If the transferred party does not answer the call within this time, the VPS considers it as a No Answer call.

1-9, 0, *, #: Dial Codes

D: Disconnect

F: Hook Flash

R: Ringback Tone Detection

T: Dial Tone Detection

S: Silence Detection

W: Wait for 1 s

A: Answer

N: Telephone Number

Transfer to Outside Parameters-Trunk Group

To access the menu for Trunk Group, follow the menu path as shown:

System Administration Top Menu-1-6-3-4-2-Trunk Group No.(1-48)

Table B-51

Parameter	Value Range (Default)	Description/Function
EFA Transfer	1. Disable 2. Enable (Disable)	Specifies whether or not the VPS uses EFA (External Feature Access) when transferring an incoming outside call to an outside line. If set to "Enable", the VPS transfers an incoming outside call to an outside line according to the EFA Transfer Sequence specified in Table B-50. This parameter is available with DPT Integration only. If set to "Disable", the VPS transfers an incoming outside call to an outside line according to the Call Transfer to Outside Sequence specified in Table B-50.
Caller ID Callback	1. Disable 2. Enable (Disable)	Specifies whether or not the VPS allows a subscriber to call back the party who left a message in his mailbox with the Caller ID number sent from the PBX. This setting applies to the trunk group number used when the message with the Caller ID number was left in his mailbox.
Outside Line Access Sequence for Caller ID Callback	Up to 12 digits consisting of 0-9, *, #, F, R, T, S, W (9T)	Specifies the sequence of outside line access codes for Caller ID Callback. This parameter is available when the VPS executes Caller ID Callback without using EFA.
Caller ID Modify Table (1-4)	1-4 (1)	Specifies the number of the Caller ID Modify Table that is used when the VPS converts the Caller ID Number sent from the PBX to the VPS.

Transfer to Outside Parameters-Caller ID Modify Table

To access the menu for Caller ID Modify Table, follow the menu path as shown:

System Administration Top Menu-1-6-3-4-3-Table No.(1-4)

Table B-52

Parameter	Value Range (Default)	Description/Function
Local Area Code/ International Code	Up to 6 digits consisting of 0-9 (None)	Specifies the local area/international codes that are used when the VPS converts the Caller ID Number sent from the PBX to the VPS.

Table B-52

Parameter	Value Range (Default)	Description/Function
Remove Digits (0-9)	0-9 (0)	Specifies the number of digits to be deleted from the telephone number (sent from the PBX) to make up a telephone number for a local area/international/long distance call. Digits are removed from the beginning of the received digits.
Additional Dial	Up to 4 digits consisting of 0-9, *, # (None)	Specifies the number to be added to the telephone number (sent from the PBX) to make up a telephone number for a local area/international/long distance call. The number is added to the beginning of the received digits.

VPS Port Parameters

These parameters specify the extension numbers of VPS ports.

To access the menu for VPS Port Parameters, follow the menu path as shown:

System Administration Top Menu-1-6-3-5

Table B-53

Parameter	Value Range (Default)	Description/Function
Extension No. of the VPS port 1-24	2-4 digits (KX-TVS125: 165-170 [Port 1-6]; KX-TVS225: 165-170 [Port 1-6], 177-178 [Port 7-8], 181-184 [Port 9-12]; KX-TVS325: None [Port 1-24])	Specifies the extension number of each VPS port. Note Extension numbers of the VPS ports will automatically be assigned when: (1) Auto Configuration is executed, or (2) PBX type has been changed. The maximum number of ports depends on the VPS model.

Appendix C
SYSTEM MANAGER'S GUIDE

C1 ACCESSING THE SYSTEM MANAGER'S MAILBOX

The System Manager's Mailbox must be accessed before performing any System Manager task. To access the System Manager's Mailbox, three items of information must be known: the telephone number connected directly to the Voice Mail Service, the System Manager's Mailbox Number and the Password for that mailbox (if assigned). The System Manager's Mailbox Number is 99, 999, 9999 or 99999 depending upon the mailbox number length specified in System Programming. The System Manager's password is assigned through the System Manager's Service.

Notes

- If your VPS is the KX-TVS125 or KX-TVS225, the mailbox number is 999 by default.
- If your VPS is the KX-TVS325, the mailbox number is 9999 by default.

To Access the System Manager's Mailbox

1. **Dial** the **Extension Number** connected to the Voice Mail Service. Or **Dial** any **VPS Extension Number** and **Press** [#] [6] (Service Access Command).

*Please enter your party's mailbox number.
To enter by name, press [#] and [1].
If you are using a rotary telephone, stay on the line.
To call the operator, press [0].*

2. **Press** [✖], then **Type** the **System Manager's Mailbox Number** (99, 999, 9999 or 99999).

Enter your password, followed by [#].

3. **Type** the **Password** followed by [#]. The Main Menu of System Manager's Service will be played:

You have (number) new message(s).

To receive the message, press [1].

To deliver a message, press [2].

To customize your mailbox, press [3].

To check the mailbox distribution, press [4].

For a system report, press [5].

For other features, press [6].

To end this call, press [].*

C2 SETTING UP MAILBOXES

The System Manager's primary function is to create mailboxes for new subscribers and to maintain system organization by deleting unneeded passwords and mailboxes.

Note

While the System Administrator programs via a personal computer, the System Manager cannot set up mailboxes. The VPS plays "Sorry, this function is not available".

Creating and Editing a Mailbox

The System Manager can both create and edit Subscriber Mailboxes by following the steps below.

At any step, when editing an assigned mailbox's parameters, change current settings by **Pressing [1]**. To leave the current setting unchanged, **Press [2]**.

When creating a new mailbox, the following parameters can be set:

- *Mailbox Number*
- *Subscriber's Voiced Name—The VPS allows a maximum of 4 s to record the name. The name must be spoken slowly and clearly. Use the subscriber's last name.*
- *Extension Number*
- *Initial 3 or 4 Letters of the Subscriber's Last Name—Enter only the first 3 or 4 letters of the owner's last name.*
- *Class of Service Number—Enter any COS number (1-62).*
- *Interview Mailbox Number—Interview Mailbox Numbers must be different from Subscriber Mailbox Numbers*
- *All Calls Transfer Mailbox*

Follow the steps listed below to create, edit or delete any mailbox parameter.

1. **Log in** to the Main Menu.
2. **Press [6]** for Other Features.
3. **Press [1]** for Mailbox Setup.
4. **Press [1]** to Assign or Edit.
5. **Type** the **mailbox number**.
6. **Press [2]** to accept the entry.

7. As each parameter plays:
 - a) **Press [1]** to enter the new parameter or **[2]** to leave the parameter unchanged.
 - b) Enter the parameter.
 - c) Confirm the new parameter is correct and **Press [2]** to accept it.
8. The All Calls Transfer to Mailbox parameter is the last parameter to be entered. When this entry is completed, the prompt at Step 4 will appear. Continue assigning or editing other mailboxes by repeating Steps 5-7.
9. To return to the Main Menu, **Press [*]** twice.

Deleting a Mailbox

The System Manager must delete the mailboxes that are no longer needed. When another person accesses the VPS, the action is automatically canceled.

1. **Log in** the Main Menu.
2. **Press [6]** for Other Features.
3. **Press [1]** for Mailbox Setup.
4. **Press [2]** for Delete.
5. **Type** the **mailbox number**.
6. **Press [1]** to delete the mailbox.

Resetting a Mailbox Password

When a password is forgotten, the System Manager must reset the password before it can be reassigned by the subscriber.

1. **Log in** the Main Menu.
2. **Press [6]** for Other Features.
3. **Press [1]** for the Mailbox Setup.
4. **Press [3]** for Password Reset.
5. **Type** the **mailbox number**.
6. **Press [1]** to delete the password.

Note

After the password is reset, the conditions will be as follows:

<Subscribers' Mailboxes>

If this parameter is set to "Yes", the password will be initialized to the default password. If this parameter is set to "No", the password will be cleared.

<Managers' Mailboxes>

The password is initialized to "No password".

When the System Manager's password is reset, the "System Manager Access from Telephone" parameter will automatically change to "Disable".

When the Message Manager's password is reset, the "Message Manager Access from Telephone" parameter will automatically change to "Disable".

C3 SETTING COS (CLASS OF SERVICE) PARAMETERS

Class of Service defines the set of VPS services available to mailbox owners. A maximum of 64 Class of Services can be established. Each Class of Service can be set using the telephone. COS No.63 and No.64 are assigned to the Message Manager and the System Manager respectively.

For a complete explanation of COS parameters, please see Table B-7 and Table B-8 in B3 SYSTEM ADMINISTRATION—SETTING COS (CLASS OF SERVICE) PARAMETERS.

Follow the steps detailed below to set the following Class of Service parameters:

- *New Message Retention Time—Up to 30 days/0: Unlimited.*
- *Saved Message Retention Time—Up to 30 days/0: Unlimited.*
- *Message Length—Length ranges from 1-6 min/0: Unlimited.*
- *Number of Messages—The number of messages range from 5-100.*
- *Total Message Time—Total message time ranges from 5-100 min/0: Unlimited.*
- *Message Retrieval Order—Settings are LIFO (Last In First Out) or FIFO (First In First Out).*
- *Message Scanning with Information—Settings are enable or disable.*
- *Subscriber Service Prompt Mode*
 1. *System Prompt*
 2. *User 1 Prompt*
 3. *User 2 Prompt*
- *Delete Message Confirmation—Settings are enable or disable.*
- **1Envelope Information Position—Settings are Before, After, or None.*
- **1Time and Date Stamp Position—Settings are Before, After, or None.*
- *Caller ID Callback—Settings are enable or disable.*
- **1Direct Mailbox Access—Settings are enable or disable.*
- **2Remote Call Forward to CO—Settings are enable or disable.*
- **1Play System Prompt after Personal Greeting—Settings are enable or disable.*
- **1Call Waiting on Busy—Settings are enable or disable.*
- **1Message Cancel for Live Call Screening—Settings are enable or disable.*
- **1 Intercom Paging Group Number—1-17*
- **1Number of Caller IDs for Personal Caller Name Announcement—0-30*
- **1Play Personal Greeting for Caller ID—Settings are enable or disable.*
- **1Caller ID Screening—Settings are enable or disable.*
- **1Call Transfer to Outside—Settings are enable or disable.*
- **1Toll Saver—Settings are disable, DID, or Caller ID.*
- **1Subscriber Tutorial—Settings are enable or disable.*
- **2Message Notification—Settings are enable or disable.*
- **1External Message Delivery—Settings are enable or disable.*
- **1Auto Forwarding—Settings are enable or disable.*

*1 Not available for COS No.63 (Message Manager) and COS No.64 (System Manager)

*2 Not available for COS No.64 (System Manager)

Note

While the System Administrator programs via a personal computer, the System Manager cannot set COS parameters. The VPS plays "Sorry, this function is not available".

1. **Log in** the Main Menu.
2. **Press [6]** for Other Features.
3. **Press [2]** to set Class of Service.
4. **Type the Class of Service Number (1-64).**

New Message Retention Time

5.
 - a) The current setting plays. **Press [1]** to change the current time.
 - b) **Type the retention time (up to 30 days or 0: Unlimited).**
 - c) Confirm the entry is correct and **Press [2]** to accept it.

Saved Message Retention Time

6.
 - a) The current setting plays. **Press [1]** to change the current time.
 - b) **Type the retention time (up to 30 days or 0: unlimited).**
 - c) Confirm the entry is correct and **Press [2]** to accept it.

Message Length

7.
 - a) The current setting plays. **Press [1]** to change the current length.
 - b) **Type the message length (1-6 min or 0: unlimited).**
 - c) Confirm the entry is correct and **Press [2]** to accept it.

Number of Messages

8.
 - a) The current setting plays. **Press [1]** to change the current number.
 - b) **Type the number of messages (5-100).**
 - c) Confirm the entry is correct and **Press [2]** to accept it.

Total Message Time

9.
 - a) The current setting plays. **Press [1]** to change the current time.
 - b) **Type the total message time (5-100 min or 0: unlimited).**
 - c) Confirm the entry is correct and **Press [2]** to accept it.

Message Retrieval Order

10.
 - a) The current setting plays. **Press [1]** to change the current order (LIFO or FIFO).
 - b) Confirm the entry is correct and **Press [2]** to accept it.

Message Scanning with Information

11.
 - a) The current setting plays. **Press [1]** to change the setting (enable or disable).
 - b) Confirm the entry is correct and **Press [2]** to accept it.

Subscriber Service Prompt Mode

12.
 - a) The current setting plays. **Press [1], [2], or [3]** to change the desired mode.
 - *[1] System Prompt*
 - *[2] User 1 Prompt*
 - *[3] User 2 Prompt*
 - b) Confirm the entry is correct and **Press [4]** to accept it.

Delete Message Confirmation

13.
 - a) The current setting plays. **Press [1]** to change the setting (enable or disable).
 - b) Confirm the entry is correct and **Press [2]** to accept it.

Envelope Information Position

14.
 - a) The current setting plays. **Press [1], [2], or [3]** to change the current order (Before, After, or None).
 - *[1] Before*
 - *[2] After*
 - *[3] None*
 - b) Confirm the entry is correct and **Press [4]** to accept it.

Time and Date Stamp Position

15. **a)** The current setting plays. **Press [1], [2], or [3]** to change the current order (Before, After, or None).
- *[1] Before*
 - *[2] After*
 - *[3] None*
- b)** Confirm the entry is correct and **Press [4]** to accept it.

Caller ID Callback

16. **a)** The current setting plays. **Press [1]** to change the setting (enable or disable).
- b)** Confirm the entry is correct and **Press [2]** to accept it.

Direct Mailbox Access

17. **a)** The current setting plays. **Press [1]** to change the setting (enable or disable).
- b)** Confirm the entry is correct and **Press [2]** to accept it.

Remote Call Forward to CO

18. **a)** The current setting plays. **Press [1]** to change the setting (enable or disable).
- b)** Confirm the entry is correct and **Press [2]** to accept it.

Play System Prompt after Personal Greeting

19. **a)** The current setting plays. **Press [1]** to change the setting (enable or disable).
- b)** Confirm the entry is correct and **Press [2]** to accept it.

Call Waiting on Busy

20. **a)** The current setting plays. **Press [1]** to change the setting (enable or disable).
- b)** Confirm the entry is correct and **Press [2]** to accept it.

Message Cancel for Live Call Screening

21. **a)** The current setting plays. **Press [1]** to change the setting (enable or disable).
- b)** Confirm the entry is correct and **Press [2]** to accept it.

Intercom Paging Group Number

22.
 - a) The current setting plays. **Press [1]** to change the current number.
 - b) **Type the group number (1-17).**
 - c) Confirm the entry is correct and **Press [2]** to accept it.

Note

If set to "17 (Group 17)", the Intercom Paging feature is activated for all groups (1-16).

Number of Caller IDs for Personal Caller Name Announcement

23.
 - a) The current setting plays. **Press [1]** to change the current number.
 - b) **Type the number of Caller IDs (0-30).**
 - c) Confirm the entry is correct and **Press [2]** to accept it.

Play Personal Greeting for Caller ID

24.
 - a) The current setting plays. **Press [1]** to change the setting (enable or disable).
 - b) Confirm the entry is correct and **Press [2]** to accept it.

Caller ID Screening

25.
 - a) The current setting plays. **Press [1]** to change the setting (enable or disable).
 - b) Confirm the entry is correct and **Press [2]** to accept it.

Call Transfer to Outside

26.
 - a) The current setting plays. **Press [1]** to change the setting (enable or disable).
 - b) Confirm the entry is correct and **Press [2]** to accept it.

Toll Saver

27.
 - a) The current setting plays. **Press [1]** to change the current order (disable, DID, or Caller ID).
 - *[1] disable*
 - *[2] DID*
 - *[3] Caller ID*
 - b) Confirm the entry is correct and **Press [4]** to accept it.

Subscriber Tutorial

28. **a)** The current setting plays. **Press [1]** to change the setting (enable or disable).
- b)** Confirm the entry is correct and **Press [2]** to accept it.

Message Notification

29. **a)** The current setting plays. **Press [1]** to change the setting (enable or disable). If the Message Notification is enabled, go to Step 29b below.
- b)** **Press [1], [2], [3], [4], or [5]** to choose the desired Beeper Callback Number Entry Mode.
- *[1] Caller Select Mode*
 - *[2] Without message mode*
 - *[3] Before message recording mode*
 - *[4] After message recording mode*
 - *[5] Disable All Entry Mode (Caller cannot access beeper)*
- c)** Confirm the entry is correct and **Press [6]** to accept it.
- d)** The current setting of MWL Notification for Unreceived Message plays. **Press [1]** to change the setting (enable or disable).
- e)** Confirm the entry is correct and **Press [2]** to accept it.
- f)** The current setting of Device Notification for Unreceived Message plays. **Press [1]** to change the setting (enable or disable).
- g)** Confirm the entry is correct and **Press [2]** to accept it. Return to Step 29a above.

External Message Delivery

30. **a)** The current setting plays. **Press [1]** to change the setting (enable or disable). If the External Message Delivery is enabled, set the prompt mode for receiving External Delivery Messages (go to Step 30b below).
- b)** The current prompt mode plays. **Press [1], [2], [3], or [4]** to choose the desired mode.
- *[1] System Prompt*
 - *[2] User 1 Prompt*
 - *[3] User 2 Prompt*
 - *[4] Selective Prompt*
- c)** Confirm the entry is correct and **Press [5]** to accept it. Return to Step 30a above.

Auto Forwarding

31.
 - a) The current setting plays. **Press [1]** to change the setting (enable or disable). If Auto Forwarding is enabled, go to Step 31b below.
 - b) The current forwarding destination mailbox number plays. **Press [1]** to change the mailbox number.
 - c) **Type the mailbox number.**
 - d) Confirm the entry is correct and **Press [2]** to accept it.
 - e) The current delay time is played. **Press [1]** to change the setting. The delay time is the period of time that the VPS must wait before forwarding messages. For example, enter 115# to set the delay time to 1 h 15 min; 30# to set 30 min.
 - f) Confirm the entry is correct and **Press [2]** to accept it.
 - g) The current forwarding mode is played. **Press [1]** to change the setting (copy or move).
 - h) Confirm the entry is correct and **Press [2]** to accept it. Return to Step 31a above.

C4 SETTING THE SYSTEM CLOCK

The system clock can be set directly from the telephone. It is important to set the exact time because Message Waiting Notification, External Message Delivery, redialing and rescheduling of External Message Delivery, and Automatic Message Deletion are all scheduled using this setting. The System Administrator and Message Manager are also able to set the clock.

The system automatically adjusts the time as appropriate when daylight saving time begins and ends.

Note

The System Manager cannot set the system clock while:

- the System Administrator programs via a personal computer,
- the Message Manager sets the system clock, records the Voice Labels and System Caller Names, and customizes the Message Manager's Mailbox.

"The VPS plays Sorry, this function is not available".

1. **Log in** the Main Menu.
2. **Press [6]** for Other Features.
3. **Press [3]** to set the time and date.
4. **Press [1]** to change the current time.
5. **Type the current time and Press [#].**

Note

Press [0] for help. "For example, to enter 5 o'clock, press 5 and # or to enter 5:15, press 5, 1, 5, and #".

6. **Press [1]** for **AM** or **[2]** for **PM**.

Note

This selection is not available if "24-h" is selected for Time Stamp for User Prompts. See "Position of "AM/PM" in Time Stamp for User 1 Prompt" and "Position of "AM/PM" in Time Stamp for User 2 Prompt" in Table B-28 in B6.5 Prompt Setting.

7. **Press [2]** to accept the time.
8. **Press [1]** to change the current date.
9. **Type the current month and Press [#].**

Note

Press [0] for help. "For example, to enter January, press 1 and #".

10. **Type** the day and **Press [#]**.
11. **Type** the **last 2 digits of the year** and **Press [#]**.
12. **Press [2]** to accept the date.

C5 CHANGING THE SERVICE MODE SETTING

The VPS automatically activates the appropriate call handling method according to the Time Service setting (Day, Night, Lunch, and Break Services) for each Time Group 1-8; however, the System Manager or System Administrator can change the current call handling method by assigning a specific Service Mode to the desired Time Group.

Once the Service Mode has been changed, it is retained unless the System Manager or System Administrator changes it again, even after the power is cut and restored.

Note

While the System Administrator programs via a personal computer, the System Manager cannot change the Service Mode setting. The VPS plays "Sorry, this function is not available".

Assigning the Service Mode

There are 6 Service Modes available:

- *Automatic Mode: Operates according to the setting in Time Service (default)*
- *Manual Day Mode: Operates only in Day Mode*
- *Manual Night Mode: Operates only in Night Mode*
- *Manual Lunch Mode: Operates only in Lunch Mode*
- *Manual Break Mode: Operates only in Break Mode*
- *PBX Control Mode: Operation changes depending on PBX time period (available only with DPT Integration)*

In the Automatic Mode, services have this order of priority:

Toll Saver > Holiday Service > Caller ID Call Routing > DID Call Routing > Trunk Service > Port Service

(Toll Saver has the highest priority.)

In the Manual Modes (Day, Night, Lunch, or Break), services have this order of priority:

Caller ID Call Routing > DID Call Routing > Trunk Service > Port Service

(Toll Saver and Holiday Service are disregarded.)

When a call is received through a PBX in the PBX Control Mode, the VPS obtains the Time Service (Day, Night, Lunch or Break) setting from the PBX and operates accordingly.

When the Integration Mode is other than DPT Integration and the PBX Control Mode is selected, the VPS will operate in the Automatic Mode.

Depending on the model and/or the software version of the connected PBX, the PBX Control Mode may not function properly. For more information, call National Parts Center at 1-800-833-9626.

Follow the steps below to assign a Service Mode to each Time Group 1-8.

1. **Log in** the main menu.
2. **Press [6]** for other features.
3. **Press [4]** to change Service Mode setting.
4. **Type the Time Group number (1-8).**
5. The VPS plays the current setting. **Press [1]** to change the setting.
6. **Press [1], [2], [3], [4], [5], or [6]** to choose the desired Service Mode entry.
 - *[1] Automatic Mode: Operates according to the setting in Time Service (default)*
 - *[2] Manual Day Mode: Operates only in Day Mode*
 - *[3] Manual Night Mode: Operates only in Night Mode*
 - *[4] Manual Lunch Mode: Operates only in the Lunch Mode*
 - *[5] Manual Break Mode: Operates only in the Break Mode*
 - *[6] PBX Control Mode: Operation changes depending on PBX time period*
7. Confirm the entry is correct and **Press [2]** to accept it.

C6 CHANGING THE COMPANY GREETING AND INCOMING CALL SERVICE SETTING

Company Greeting greets all incoming callers. The System Manager or System Administrator can choose the appropriate company greeting to each individual Time Service period (Day, Night, Lunch, and Break) for each port and trunk (CO line) group. The default is set at the System Greeting prior to factory shipment.

The System Manager or System Administrator can also choose a desired Incoming Call Service to each individual Time Service period for each port and trunk (CO line) group. The default is set at the Automated Attendant Service prior to factory shipment.

Note

While the System Administrator programs via a personal computer, the System Manager cannot change the Company Greeting setting. The VPS plays "Sorry, this function is not available".

1. **Log in** the Main Menu.
2. **Press [6]** for Other Features.
3. **Press [5]** to change Port/Trunk setting.
4. **Press [1]** to change the port setting, **or [2]** to change the trunk service setting.
5. **Type 1-24** (port number) **or 1-48** (trunk group number).

Note

The maximum number of ports depends on the VPS model.

6. **Press [1], [2], [3], or [4]** to choose the desired Time Service period entry.
 - *[1] Day Time service*
 - *[2] Night Time service*
 - *[3] Lunch Time service*
 - *[4] Break Time service*
7. **Press [1]** to change the Company Greeting setting, **or [2]** to change the Incoming Call Service setting.
8. The current setting plays. **Press [1]** to change the setting, **or [2]** to accept it. If you press [1], **Go to Step 9** for the Company Greeting setting, or **Go to Step 11** for the Incoming Call Service setting.
9. **Press [1], [2], or [3]** to choose the desired setting entry.
 - *[1] To change Company Greeting number*

- [2] To set System Greeting—**Go to Step 13**
- [3] To disable—**Go to Step 13**

10. Type the Company Greeting number **1-32**—**Go to Step 13**.

11. Press [1], [2], [3], [4], or [5] to choose the desired setting entry.

- [1] To set Voice Mail Service—**Go to Step 13**
- [2] To set Automated Attendant Service—**Go to Step 13**
- [3] To set Custom Service
- [4] To set Interview Service
- [5] To disable

Note

You cannot disable the setting in the port setting.

12. Type the Custom Service prompt number **1 through 100**, or the Interview Mailbox number.

13. Confirm the entry is correct and **Press** [2] to accept it.

C7 INITIALIZING THE INTERNAL MODEM (KX-TVS325 Only)

An internal modem card is installed prior to factory shipment. This card is necessary for programming and maintenance from remote locations. System Manager can initialize the internal modem through the telephone.

Note

While the System Administrator programs via a personal computer, the System Manager cannot initialize the internal modem. The VPS plays "Sorry, this function is not available".

This menu is not available if the internal modem card has not been installed.

1. **Log in** the Main Menu.
2. **Press [6]** for Other Features.
3. **Press [6]** to initialize the internal modem.

If the initialization is unsuccessful, the VPS plays the message "*Initialization failed*". In this case, retry after ensuring that the modem card has been installed properly.

C8 CHECKING SYSTEM USAGE (SYSTEM REPORTS)

The System Manager can generate 8 System Reports to help monitor the VPS operating status. The reports are sent from the RS-232C port to either a printer or a terminal. (The System Administrator is also able to output System Reports.)

Obtaining System Reports

1. **Log in** in the Main Menu.
2. **Press [5]** for the System Report Menu.
3. **Press [1], [2], [3], [4], [5], [6], [7], or [8]** to generate the desired report.
 - *[1] System Service Report*
 - *[2] Disk Usage Report*
 - *[3] Port Usage Report*
 - *[4] Mailbox Usage Report*
 - *[5] Mailbox Parameter Report*
 - *[6] Call Account Report*
 - *[7] Class of Service Parameter Report*
 - *[8] Fax Call Report*

Note

The Mailbox Parameter Report is displayed as "Mailbox Assignments". The Class of Service Parameter Report is displayed as "COS Assignments".

4. For Disk Usage Report, Port Usage Report, Mailbox Usage Report, Call Account Report or Fax Call Report, **Press [1]**. To generate the Mailbox Usage Report, **Go to Step 5**.
5. Mailbox Usage Report—**Type** the **mailbox number** of the start of the range.

Note

If a [#] is entered in place of each digit of the mailbox numbers (e.g., # # # for 3-digit mailbox numbers), reports for all mailboxes will be printed and the System Report Menu will appear. In this case, Step 6 can be skipped.

6. **Press [1]** to specify the mailbox range and **Type** the **mailbox number** of the end of the range, or **Press [2]** to obtain all mailbox usage counts. This mailbox number is the end of the mailbox range. The mailbox number entered in Step 5 is the start of the range. For example, to specify the mailbox range 1001 through 1209, enter 1001 in Step 5 and 1209 in Step 6.

Note

While the System Administrator programs via a personal computer, a System Report will not be generated. The System Report starts to be generated after the System

Administrator has completed programming and system prompt [<] is displayed on the personal computer.

Clearing the Reports

The Port Usage, Disk Usage, Mailbox Usage, and Fax Call Reports can be cleared.

1. **Log in** the Main Menu.
2. **Press [5]** for the System Report Menu.
3. **Press [2]** to clear the Disk Usage Reports, **[3]** to clear the Port Usage Reports, **[4]** to clear the Mailbox Usage Reports, **[6]** to clear the Call Account Report, or **[8]** to clear the Fax Call Report.
4. **Press [2]** to clear the report. To clear the Mailbox Usage Reports, **Go to Step 5**.
5. **Type** the **mailbox number** of the start of the range.

Note

If a [#] is entered in place of each digit of the mailbox numbers (e.g., # # # for 3-digit mailbox numbers), reports for all mailboxes will be cleared and the System Report Menu will appear. In this case, Step 6 can be skipped.

6. **Press [1]** to specify the mailbox range, and **Type** the **mailbox number** of the end of the range. **Press [2]** to clear all Mailbox Usage Reports.

C9 DELIVERING MESSAGES

The System Manager can deliver the same message to all or specified subscribers' mailboxes. When delivering a message to specified mailboxes, he can check the distribution status of each message.

Delivering Messages to All Mailboxes (Broadcasting Messages)

The Broadcasting Messages feature allows the System Manager to deliver the same message to all subscribers at the same time. The message to broadcast is recorded in the System Manager's mailbox. This feature is useful when informing subscribers about the current VPS status such as remaining hard disk capacity, requesting that unnecessary messages be erased, etc.

1. **Log in** the Main Menu.
2. **Press [2]** to deliver a message.
3. **Press [1]** to record a broadcast message.
4. Record a broadcast message and **Press [1]**.
5. **Press [2]** to accept the message recorded.

Delivering Messages to Specified Mailboxes

Use this feature to deliver the same message to one or more subscriber mailboxes by specifying their numbers.

1. **Log in** the Main Menu.
2. **Press [2]** to deliver a message.
3. **Press [2]** to deliver a message.
4. **Type the mailbox number** of the intended recipient.

Note

Enter by name by Pressing [#] [1] first.
Use a System Group Distribution List by specifying its number.

5. **Press [2]** to accept the number if it is correct.

Note

Press [2] to add mailbox numbers. Press [3] to review the mailing list. Press [*] to cancel message transfer.

6. **Press [1]** to record a message.
7. **Record the message** at the tone and **Press [1]**.
8. **Press [2]** to accept the entry.
9. **Press [1]** to specify the delivery time and the private status.

Note

Press [2] to send the message immediately and return to the Main Menu.

10. **Press [1]** to specify the delivery time.
11. **Type the time** and **Press [#]**.
12. **Press [1]** for **AM** or **[2]** for **PM**.

Note

This selection is not available if "24-h" is selected for Time Stamp for User Prompts. See "Position of "AM/PM" in Time Stamp for User 1 Prompt" and "Position of "AM/PM" in Time Stamp for User 2 Prompt" in Table B-28 in B6.5 Prompt Setting.

13. **Type the date (month and day)** and **Press [#]**.
14. **Press [2]** to accept the entry.
15. **Press [1]** to make this message private; otherwise, **Press [2]**.

Checking Mailbox Distribution

Use this feature to check if messages have been delivered to recipients.

1. **Log in** the Main Menu.
2. **Press [4]** to check distribution status.
3. **Press [3]** to cancel the message or delete verification.

Note

Press [1] to listen to messages. Press [1] twice to check the previous message. Press [2] to check the next message.

4. **Press [1]** to delete verification of this message, or **[2]** to cancel message delivery.

C10 CUSTOMIZING THE SYSTEM MANAGER'S MAILBOX

In order to ensure system security, establish a password consisting of up to 10 numeric characters. Anyone requesting access to the System Manager's service will be required to enter this password before proceeding.

Note

While the System Administrator programs via a personal computer, the System Manager cannot access this service. The VPS plays "Sorry, this function is not available".

1. **Log in** the Main Menu.
2. **Press [3]** to customize the mailbox.
3. The VPS plays the current password setting. **Press [1]** to change the mailbox password. If a password has not yet been assigned, go to Step 4. **Press [2]** to accept the current setting.
4. **Type the password** and **Press [#]**.

Note

If a password is not needed, Press [#]. It is recommended that the password be set to maintain security.

5. The VPS plays the current password setting. **Press [2]** to accept it.

C11 LISTENING TO SYSTEM MANAGER MESSAGES

1. **Log in** the Main Menu.
2. The VPS plays the number of new messages. **Press [1]** to listen to the messages.
3. The VPS plays each message, identifying the sender and indicating when the message was recorded. **Press [0]** to listen to the entire menu.
 - *[1] Repeat this message*
 - *[1] [1] Replay the Previous Message*
 - *[2] Play the Next Message*
 - *[3] ([1]) Erase this Message*
 - *[4] Reply*
 - *[5] Rewind*
 - *[6] Fast Forward*
 - *[7] Transfer*
 - *[8] Message Scan*

Appendix D
MESSAGE MANAGER'S GUIDE

D1 ACCESSING THE MESSAGE MANAGER'S MAILBOX

The Message Manager's Mailbox must be accessed before performing any Message Manager task. To access the Message Manager's mailbox, three items of information must be known: the telephone number connected directly to the Voice Mail Service, the Message Manager's Mailbox Number, and the Message Manager's Password (if assigned). The Message Manager's Mailbox Number is 98, 998, 9998, or 99998 depending upon the mailbox number length specified in System Programming. The Message Manager's password is assigned through the Message Manager's Service.

Notes

- If your VPS is the KX-TVS125 or KX-TVS225, the mailbox number is 998 by default.
- If your VPS is the KX-TVS325, the mailbox number is 9998 by default.

To Access the Message Manager's Mailbox

1. **Dial** the **Extension Number** connected to the Voice Mail Service. Or **Dial** any **VPS Extension Number** and **Press [#] [6]** (Service Access Command).

*Please enter your party's mailbox number.
To enter by name, press [#] and [1].
If you are using a rotary telephone, stay on the line.
To call the operator, press [0].*

2. **Press [✳]**, then enter the **Message Manager's Mailbox Number** 98, 998, 9998 or 99998.

Enter your password, followed by [#].

3. **Type** the **Password** followed by [#]. The Main Menu of Message Manager's Service will be played.

*You have (number) new message(s).
To transfer General Delivery Mailbox messages, press [1].
To set up message waiting notification, press [2].
To customize your mailbox, press [3].
To set the clock, press [4].
To modify message, press [5].
To set station call forwarding, press [6].
To end this call, press [✳].*

D2 MANAGING THE GENERAL DELIVERY MAILBOX

One of the Message Manager's functions is to check the General Delivery Mailbox for messages and transfer them to the appropriate mailbox or mailboxes (System Group Distribution Lists may be used). This can be done at any time using the telephone.

Listening to Messages

The Message Manager can monitor the status of the General Delivery Mailbox through his mailbox. He can listen to the messages stored in the General Delivery Mailbox and, if necessary, transfer them to their intended recipients.

1. **Log in** the Main Menu.
2. The VPS plays the number of new messages. **Press [1]** to listen to the messages.
3. The VPS plays each message, identifying the sender and indicating when the message was recorded. **Press [0]** to listen to the entire menu.
 - *[1] Repeat this Message*
 - *[1] [1] Replay the Previous Message*
 - *[2] Play the Next Message*
 - *[3] ([1]) Erase this Message*
 - *[4] Reply*
 - *[5] Rewind*
 - *[6] Fast Forward*
 - *[7] Transfer*
 - *[8] Message Scan*
 - *[9] Save this Message as New*

Transferring Messages

Messages left in the General Delivery Mailbox must be transferred to their intended recipients with voice comments attached when necessary. When a message has been transferred, we recommend that the original be deleted from the General Delivery Mailbox.

1. **Log in** the Main Menu.
2. **Press [1]** to transfer messages from the General Delivery Mailbox.
3. The VPS plays the first (next/last) message. **Press [7]** to transfer the message.
4. **Type the destination mailbox number.**

5. **Press [2]** to accept the number.

6. **Press [2]** to transfer with comment.

Note

Press [1] to transfer messages without comment. Press [3] to add a mailbox number.

Press [4] to review the Mailing List.

7. **Record the comments** and **Press [1]**.

8. **Press [2]** to accept the comments entered.

D3 SETTING UP MESSAGE WAITING NOTIFICATION

The VPS can notify the Message Manager when unplayed messages are waiting in his mailbox. Two types of Message Waiting Notification are available: Notification by Message Waiting Lamp and Notification by Calling.

Setting Message Waiting Lamp Status

The VPS illuminates the message waiting lamp on the extension when a new message is recorded in the Message Manager's Mailbox.

Note

The extension assigned for Operator 1 in the Day Mode is the Message Manager's extension. However, its default extension number (0) cannot be used with the Message Waiting Lamp feature. When using this feature, you must assign the extension number that is included in the Extension Numbering Plan.

1. **Log in** the Main Menu.
2. **Press [2]** to set Message Waiting Notification
3. **Press [1]** to change the Message Waiting Lamp Notification Status.
4. **Press [1]** to change the Message Waiting Lamp Notification Status, or **[2]** to accept it.

Setting Notification by Calling Status

The VPS calls the preset telephone or beeper when a new message is recorded in the Message Manager's Mailbox. Set the following parameters as appropriate.

Setting Device Status

For each device, the notification is enabled or disabled according to a preset schedule. The Message Manager cannot **enable** a device according to a schedule. The System Administrator must accomplish this task (see "Time Frame 1, 2" in Table B-5 in B2 SYSTEM ADMINISTRATION—MAILBOXES).

1. **Log in** the Main Menu.
2. **Press [2]** to set Message Waiting Notification.
3. **Press [2]** to change the Device Status.
4. **Type** the **device number (1-3)**.

Note

If a telephone number has not been assigned to the selected device number, you cannot set the device status. See "Assigning Notification Numbers" to assign a telephone number.

5. **Press [1], [2], or [3]** to select the device status.
 - *[1] Schedule (enabled on the schedule)*
 - *[2] Continuously (enabled whole day)*
 - *[3] Not Use (disabled whole day)*

Assigning Notification Numbers

Up to 3 telephone or beeper numbers can be set for message notification. Use the number keys 0 to 9, the tone/pulse switch, and the Beeper Callback Number Display Entry Code [X] to make these assignments.

When the Beeper Callback No. Entry Code is added at the end of a beeper number, the VPS will ask the caller to enter the callback number that will display on the beeper. System Programming determines if the Callback Number Entry is to be entered before, after, or without the message.

It is also possible to have the caller select whether or not to enter a callback number. The System Manager must authorize the use of the Beeper Callback No. Entry Code.

1. **Log in** the Main Menu.
2. **Press [2]** to set Message Waiting Notification
3. **Press [3]** to assign Telephone Number.
4. **Press [1]** to change the first telephone number, **[2]** to change the second telephone number, or **[3]** to change the third telephone number.
5. **Press [1]** to set the telephone number.
6. **Type** the **telephone number**.
7. **Press [2]** to accept the entry.
 - *[1] Change the telephone number*
 - *[2] Accept*
 - *[3] Review*
 - *[4] Add more digits*
 - *[5] Insert a pause*
 - *[6] Set dial mode*
 - *[7] Insert a wait for dial tone*

- *[8] Insert a beeper display command*

8. Press [1] to be notified by telephone or [2] by a beeper.

D4 CUSTOMIZING THE MESSAGE MANAGER'S MAILBOX

The Message Manager is able to customize the Message Manager's mailbox by specifying: (1) the password; (2) the extension numbers of Operator 1, 2, and 3; or (3) Telephone numbers 1 and 2 as the call forwarding destinations when Remote Call Forwarding is set to a CO line.

Note

While the System Administrator programs via a personal computer, the Message Manager cannot access this service. The VPS plays "Sorry, this function is not available".

Message Manager's Password

The Message Manager can specify the password at any time using the telephone. The password contains up to 10 numeric characters. It must be entered to execute the message management operation.

Operator's Extensions

When callers require help, they can **Press [0]** on their telephone keypad to be transferred to an operator extension. In each Day, Night, Lunch, and Break Modes, up to 3 operators (Operator 1, 2, 3) can be specified. The extension number assigned for Operator 1 in the Day Mode will be for the Message Manager.

Telephone Numbers 1 and 2 for Remote Call Forward to CO

The customization of the Message Manager's mailbox only allows you to assign Telephone number 1 and/or 2; to enable call forwarding to the telephone number assigned by following the steps below, follow the instructions in D7 REMOTE CALL FORWARDING SET.

If you should change the telephone number after you have enabled call forwarding to a CO line, you must go back to D7 REMOTE CALL FORWARDING SET to reset the call forwarding setting; otherwise, you will be transferring calls to the old telephone number unknowingly.

1. **Log in** the Main Menu.
2. **Press [3]** to customize Mailbox.
3. The VPS plays the current password setting. **Press [1]** to change the password. If a password has not yet been assigned, go to Step 4. **Press [2]** to accept the current setting—**Go to Step 6**.
4. **Type** the password and **Press [#]**.
5. The VPS plays the current password setting. **Press [2]** to accept it.

6. The VPS plays the current operator's extension setting. **Press [1]** to change or assign the operator's extension. **Press [2]** to accept the current setting, or **Press [3]** to delete the current setting—**Go to Step 9**.

Note

Operator 1's extension number cannot be deleted.

7. **Type the extension number.**
8. The VPS plays the current extension setting. **Press [2]** to accept it.
9. Repeat Steps 6-8 to assign or to delete the extension number for the Day, Night, Lunch and Break Modes for each operator.
10. The VPS plays the current Telephone number 1 setting. **Press [1]** to change the telephone number. If a telephone number has not yet been assigned, go to Step 11. **Press [2]** to accept the current setting—**Go to Step 13**.
11. **Type the telephone number** using "0-9" and "×".

Notes

- Please make sure you begin the telephone number with a Line Access Code (to seize a CO line).
- When connected to the KX-TD500, the maximum number of characters allowed to be entered is 24; when connected to other KX-T series PBX, 16.

12. The VPS plays the current Telephone number 1 setting. **Press [2]** to accept it.
13. The VPS plays the current Telephone number 2 setting. **Press [1]** to change the telephone number. If a telephone number has not yet been assigned, go to Step 14. **Press [2]** to accept the current setting.
14. **Type the telephone number** using "0-9" and "×".
15. The VPS plays the current Telephone number 2 setting. **Press [2]** to accept it.

D5 SETTING THE SYSTEM CLOCK

The Message Manager can set the system clock directly from the telephone. It is important to set the exact time because Message Waiting Notification, External Message Delivery, redialing and rescheduling of External Message Delivery, and Automatic Message Deletion are all scheduled using this setting. The System Administrator and System Manager are also able to set the clock.

The system automatically adjusts the time as appropriate when daylight saving time begins and ends.

Note

The Message Manager cannot set the system clock while:

- the System Administrator programs via a personal computer,
- the System Manager sets mailboxes and Class of Service (COS), and customizes the System Manager's Mailbox.

The VPS plays "Sorry, this function is not available".

1. **Log in** the Main Menu.
2. **Press [4]** to set the time and date.
3. **Press [1]** to change the current setting.
4. **Type the current time and Press [#].**

Note

Press [0] for help. "For example, to enter 5 o'clock, press 5 and # or to enter 5:15, press 5, 1, 5, and #".

5. **Press [1]** for **AM** or **[2]** for **PM**.

Note

This selection is not available if "24-h" is selected for Time Stamp for User Prompts. See "Position of "AM/PM" in Time Stamp for User 1 Prompt" and "Position of "AM/PM" in Time Stamp for User 2 Prompt" in Table B-28 in B6.5 Prompt Setting.

6. **Press [2]** to accept the time.
7. **Press [1]** to change the current date.
8. **Type the current month and Press [#].**

Note

Press [0] for help. "For example, to enter January, press 1 and #".

9. **Type the day and Press [#].**

10. Type the last 2 digits of the year and Press [#].

11. Press [2] to accept the date entered.

D6 RECORDING MESSAGES

The Message Manager is responsible for recording various system messages (specifically: menus, voice labels, user prompts, and system caller names). He is responsible for maintaining the following:

- *Company Greetings—Up to 32 company greetings for business/non-business and Lunch/Break hours as well as holidays can be selected, recorded, or deleted as necessary.*
 - *Company Name*
 - *The Department Dialing Menu (maximum length: 6 min)—A caller can access departments with the touch of one key. Nine Department Dialing selections (1 to 9) can be recorded.*
 - *The Custom Service Menus (maximum length: 6 min each)—Up to 100 custom service menus can be recorded. These menus guide callers to the services they require without the need for a human operator. This is the most useful and powerful feature of your Panasonic Voice Processing System. For example, the Message Manager can record menus in a wide variety of foreign languages.*
 - ** The Voice Labels (maximum length: 6 min each)—Up to 20 System Group Distribution Lists can be created by the System Administrator. Each list can have a voice label.*
 - *The User Prompts (maximum length: 6 min each)—There are 3 kinds of voice mail prompts: (1) System Prompts, (2) User 1 Prompts, and (3) User 2 Prompts. Generally, the System Prompts should be left alone; they are recorded at the factory in English. However, the Message Manager can record User 1 Prompts and User 2 Prompts in any language he wishes.*
 - *The Multilingual Selection Menu (maximum length: 6 min)—With this menu, callers can select the language they prefer to hear all prompts (mentioned in the previous paragraph, "The User Prompts"). For example, the Message Manager can record a menu like this:
For English, press (7).
For French, press (8).
For Chinese, press (9).*
 - ** The System Caller Names (maximum length: 4 s each)—Up to 120 Caller ID numbers can be registered by the System Administrator. The Message Manager is responsible for recording a name for each Caller ID number.*
- * While the System Administrator programs via a personal computer, the Message Manager cannot record the Voice Labels and System Caller Names. The VPS plays "Sorry, this function is not available".*

Recording Menus and Voice Labels

1. **Log in** the Main Menu.
2. **Press [5]** to modify messages.
3. Select the desired number to be recorded.
 - *[1] Record the Company Greetings.*
 - *[2] Record the Company Name.*
 - *[3] Record the Department Dialing Menu.*
 - *[4] Record the Custom Service Menus.*
 - *[5] Record the Voice Labels for System Group Distribution Lists.*
 - *[7] Record the Multilingual Selection Menu.*
4. For the item selected in Step 3, follow these steps:
 - For the Company Greetings—**Enter the Company Greeting Number (1-32).**
 - For the Company Name—**Go to Step 5.**
 - For the Department Dialing Menu—**Go to Step 5.**
 - For the Custom Service Menus—**Enter a Custom Service Number (1-100).** Enter [0] to record the Custom Service exit prompt.
 - For the Voice Labels—**Enter a System Group Distribution Lists number to be labeled.** (The System Administrator assigns list numbers.)
 - For the Multilingual Selection Menu—**Go to Step 5.**
5. The VPS plays the current message. **Press [1]** to change the message. If a message has not yet been recorded, go to Step 7.
6. **Press [1]** to record the message. **Press [2]** to erase the current message and return to Step 3 or 4.
7. **Record the message** at the tone and **Press [1]**.
8. **Press [2]** to accept the message.

Notes

- Press [1] to review the recorded message.
 - Press [3] to erase the recorded message and try again—Return to Step 7.
 - Press [4] to add a message.
 - Press [*] to erase the recorded message and exit—Return to Step 3.
9. Repeat Steps 4-8 to record other Company Greetings, Custom Service Menus, and/or Voice Labels.

Recording User Prompts

1. **Log in** in the Main Menu.
2. **Press [5]** to modify messages.
3. **Press [6]** to modify user prompts.
4. **Press [1]** to change User Prompt 1, or **[2]** to change User Prompt 2.
5. To change specific prompts, **Go to Step 6**.
To change all prompts in a row without reviewing the current recording, **Go to Step 7**.
6. To change specific prompts:
 - a) **Press [1]**
 - b) **Enter the prompt number** you want to change. (There is a complete list of modifiable prompts in D9 LIST OF MODIFIABLE PROMPTS.)
 - c) The VPS plays the prompt number and its prompt. If a prompt has not yet been recorded, the VPS plays the system prompt. If a prompt is turned off, "The prompt is now turned off" will play before the prompt.
 - d) **Press [1]** to record a new prompt.

Notes

- Press [2] to erase the current recording—Return to Step 6b.
(This is not available when the selected prompt is currently turned on and not recorded, or when the selected prompt has never been recorded and is currently turned off with the Utility command by the System Administrator.)
 - Press [3] to turn off the specified prompt—Return to Step 6b.
 - Press [4] to accept—Return to Step 6b.
- e) **Record a prompt** at the tone and **Press [1]** to end recording.
 - f) **Press [2]** to accept the recorded prompt.

Notes

- Press [1] to review the recorded prompt.
 - Press [3] to erase the recorded prompt and try again—Return to Step 6f.
 - Press [*] to erase the recorded prompt and exit—Return to Step 6b.
- g) Repeat Steps 6b to 6h to record other prompts.
7. To change all prompts in a row:
 - a) **Press [2]**
 - b) **Enter the prompt number** you want to change. (There is a complete list of modifiable prompts in D9 LIST OF MODIFIABLE PROMPTS.)
 - c) The VPS plays the prompt number.
 - d) **Press [1]** to change the prompt.

Notes

- Press [2] to go to Step 7g.
- Press [3] to turn off the prompt.

e) Record a prompt at the tone and **Press [1]** to end recording.

f) Press [2] to accept the recorded prompt.

Notes

- Press [1] to review the recorded prompt.
- Press [3] to erase the recorded prompt and try again—Return to Step 7e.
- Press [*] to erase the recorded prompt and exit—Go to Step 7g.

g) The VPS plays the next prompt number.

h) Repeat Steps 7d to 7g to record other prompts.

Note

User prompts can be saved in a personal computer (command SAVE through the RS-232C). Once they have been saved, they can be restored (with the command LOAD) at any time. There is a complete list of modifiable prompts and prompt numbers in D9 LIST OF MODIFIABLE PROMPTS.

Recording System Caller Names

1. **Log in** in the Main Menu.
2. **Press [5]** to modify messages.
3. **Press [8]** to modify system caller names.
4. **Enter the Caller ID List Number**^{*1} (1-120) to be modified.

Notes

- Enter [*] to return to Step 3.
- To record system caller names, first Caller ID numbers must be assigned (see B6.6 System Caller Name Announcement).

5. The VPS plays the Caller ID number and its name. To change the name, **Press [1]**. If a name has not yet been recorded for this Caller ID number, go to Step 6.

Notes

- Press [2] to accept the current name—Return to Step 4.
- Press [3] to erase the current name—Return to Step 4.

6. Record the name at the tone and **Press [1]**.

7. The VPS plays the recorded name. **Press [2]** to accept it.

^{*1} Guidance is "Caller Name Announcement number".

Notes

- Press [1] to change the recorded name—Return to Step 6.
 - Press [3] to erase the recorded name—Return to Step 4.
- 8.** Repeat Steps 4-7 to record names for other Caller ID List numbers.

D7 REMOTE CALL FORWARDING SET

The Message Manager can program his extension (assigned for Operator 1 in the Day Mode) from a remote location to forward various types of calls to a desired extension or an outside telephone. There are six forwarding settings available:

- *FWD All*—Forward all incoming calls to a desired extension number.
- *FWD Busy*—Forward all incoming calls to a desired extension number when the line is busy.
- *FWD No Answer*—Forward all incoming calls to a desired extension number when there is no answer.
- *FWD Busy or No Answer*—Forward all incoming calls to a desired extension number when the line is busy or there is no answer.
- *FWD to CO*—Forward all incoming calls to Telephone number 1 or 2 (preprogrammed in the Mailbox Setting), or to any other telephone number.
- *FWD Cancel*—Cancel the forwarding setting.

Notes

- The Remote Call Forwarding Set feature is available with DPT Integration only.
- By default, the extension number for the Message Manager's extension (assigned for Operator 1 in the Day Mode) is "0". However, the default setting cannot be used with this feature. When using this feature, you must assign the extension number that is included in the Extension Numbering Plan.
- FWD to CO must be enabled in the COS (Class of Service) setting to be utilized (see "Remote Call FWD to CO" in Table B-8 in B3 SYSTEM ADMINISTRATION—SETTING COS (CLASS OF SERVICE) PARAMETERS).
- FWD to CO must also be enabled in the COS setting in the PBX for each extension.

Assigning Remote Call Forwarding Set

1. **Log in** the Main Menu.
2. **Press [6]** to set Remote Call Forwarding.
3. **Press [1], [2], [3], [4], [5], or [6]** to select the desired forwarding setting.
 - [1] *FWD All*
 - [2] *FWD Busy*
 - [3] *FWD No Answer*
 - [4] *FWD Busy or No Answer*
 - [5] *FWD to CO*

- [6] FWD Cancel

4. For the items selected in Step 3, follow these steps:

- For FWD All—**Go to Step 5.**
- For FWD Busy—**Go to Step 5.**
- For FWD No Answer—**Go to Step 5.**
- For FWD Busy or No Answer—**Go to Step 5.**
- For FWD to CO—**Go to Step 7.**
- For FWD Cancel—**Go to Step 10.**

5. **Type the extension number.**

6. Confirm the entry is correct and **Press [2]** to accept it. **Go to Step 11.**

Note

Press [1] to change the extension number—Return to Step 5.

7. **Press [1]** or **[2]** to select Telephone number 1 or Telephone number 2 (**Go to Step 9**), or **Press [3]** to select another telephone number.

8. **Type the telephone number** using "0-9" and "×".

Notes

- Please make sure you begin the telephone number with a Line Access Code (to seize a CO line).
- When connected to the KX-TD500, the maximum number of characters allowed to be entered is 24; when connected to other KX-T series PBX, 16.

9. Confirm the entry is correct and **Press [2]** to accept it. **Go to Step 11.**

Note

Press [1] to change the telephone number. Return to Step 7.

10. Call Forwarding is canceled. **Press [2]** to accept it.

11. Call Forwarding setting data is transmitted to the PBX. If the forwarding setting or canceling has been completed properly, you will hear: *"Call forwarding accepted"* or *"Call forwarding is canceled"*.

Note

If you hear "Call Forwarding not accepted. Please check the destination number", the forwarding setting has not been completed properly at the PBX, possibly because a nonexistent extension number has been entered as the destination. It is also possible that the model of the connected PBX does not support the Remote Call Forwarding Set feature, or its software version is lower than required; for more information, call National Parts Center at 1-800-833-9626.

D8 LIST OF PROMPTS FOR VOICE MAIL AND AA SERVICE

There are over 1000 voice prompts (all listed in the next section) and they come in 3 types.

- (1) System Prompts—in English (cannot be modified)
- (2) User 1 Prompts—recordable
- (3) User 2 Prompts—in Spanish (can be erased or modified)

However, in many cases it is not necessary to record all the voice prompts (recording over 900 voice prompts is a big undertaking). When an outside party calls AA service or VM service, he only hears some of the following prompts. **Therefore, it is necessary only to record (or modify) these prompts.** Please change prompts as needed for your application. For example, prompt no. [915] could be *"Thank you for calling ABCD Travel"*, instead of *"Welcome to the Voice Processing System"*. (The maximum length of a prompt is fixed at 6 min.)

Note

To identify the prompt(s) linked to each prompt listed below, refer to the next section, D9 LIST OF MODIFIABLE PROMPTS.

Prompts Common to VM and AA Services

Table D-1

Prompt No.	Modifiable Prompts
273	Good afternoon
274	Good evening
275	Good morning
915	Welcome to the Voice Processing System
752	To enter by name, press the pound sign and 1
152	Enter the first 3 or 4 letters of the person's last name
221	For 'Q', press 7
222	For 'Z', press 9
556	Sorry, there are no more matching names
564	Sorry, this name cannot be found
303	Incorrect entry
299	If you are using a rotary telephone, stay on the line
678	To call the operator, press 0
60	Calling the operator
467	Please wait a moment
914	Welcome to the general delivery mailbox
466	Please leave a message at the tone
744	To end recording, hang up or press 1 for more features

Table D-1

Prompt No.	Modifiable Prompts
789	To pause and restart recording, press 2
819	To review, press 1
663	To accept, press 2
755	To erase and try again, press 3
674	To add, press 4
754	To erase and exit, press ✕
783	To make this message private, press 1
432	Otherwise, press 2
590	Thank you for calling

VM Prompts

Table D-2

Prompt No.	Modifiable Prompts
463	Please enter your party's mailbox number

AA Prompts

Table D-3

Prompt No.	Modifiable Prompts
462	Please enter your party's extension
921	You have a call
553	Sorry, no one is available to answer the call
781	To leave a message, press 1
749	To enter another extension, press ✕
561	Sorry, this line is busy
302	If you would like to hold, press 1
683	To cancel holding, press 2 now Otherwise, I'll try your party again

D9 LIST OF MODIFIABLE PROMPTS

The table below shows the modifiable prompts. Record prompts as User 1 or User 2. Some of the modifiable prompts are listed along with their linked prompt number. Whenever possible, record related prompts together so that the assembled sentence flows naturally and sounds like one voice.

If your VPS model is the KX-TVS325, you can change all service prompts to User 1 or User 2 by changing the DIP Switch setting (see "MODE (DIP Switch)—KX-TVS325" in 1.3.2 System Components).

If you wish to change some of service prompts to User 1 or User 2, but not all of them, please see the following sections:

- B3 SYSTEM ADMINISTRATION—SETTING COS (CLASS OF SERVICE) PARAMETERS; "Prompt Mode" of Table B-7 and Table B-8.
- B4 SYSTEM ADMINISTRATION—PORT/TRUNK SERVICE; "Incoming Call Service Prompt" of Table B-9 and Table B-10.
- B5.2 Custom Service; "Prompt Mode" of Table B-16.
- B6.5 Prompt Setting; Table B-28.

Table D-4

Prompt No.	Modifiable Prompts	Linked to Prompt No. (s)
1	1 through (number)	[1]
2	20 members maximum	[560], [2]
3	8 members maximum	[560], [3]
4	After hours greeting is (message)	[4]
5	After hours greeting is not recorded	[5]
6	All beeper entry modes are disabled	[6]
7	All caller ID numbers deleted	[7]
8	All calls transfer to mailbox disabled	[8]
9	All calls transfer to mailbox enabled	[9]
10	All mailboxes are assigned	[10]
11	All messages erased	[11]
12	All transfer services disabled	[12]
13	AM	[13]
14	and	[14] [359], [15], [14] [367], [14]
15	and transferred via (mailbox number)	[359], [15], [14] [15]
16	Answer length is (number)	[16], [507]

Table D-4

Prompt No.	Modifiable Prompts	Linked to Prompt No. (s)
17	Any digit on the telephone keypad can be used	[17]
18	APRIL	[18]
19	at	[19] [654], [19] [345], [483], [19] [365], [19], [220], [284] [365], [19], [220], [283] [182], [420], [19] [360], [19] [346], [912], [19] [183], [19] [360], [19], [220], [284]
20	(number) attempts were busy	[20]
21	(number) attempts were no answer	[21]
22	(number) attempts were successful	[22]
23	AUGUST	[23]
24	Auto forwarding disabled	[24]
25	Auto forwarding enabled	[25]
26	because message retention time expired	[181], [911], [26]
27	Beeper access disabled	[27]
28	Beeper access enabled	[28]
29	Beeper callback number entry mode is after message recording	[29]
30	Beeper callback number entry mode is before message recording	[30]
31	Beeper callback number entry mode is caller select	[31]
32	Beeper callback number entry mode is without message	[32]
33	being delivered now	[366], [33]
34	Break mode first operator's extension is (extension number)	[34]
35	Break mode first operator's extension is not assigned	[35]
36	Break mode second operator's extension is (extension number)	[36]

Table D-4

Prompt No.	Modifiable Prompts	Linked to Prompt No. (s)
37	Break mode second operator's extension is not assigned	[37]
38	Break mode third operator's extension is (extension number)	[38]
39	Break mode third operator's extension is not assigned	[39]
40	Busy signal greeting is (message)	[40]
41	Busy signal greeting is not recorded	[41]
42	Call blocking enabled	[42]
43	Call forwarding accepted	[43]
44	Call forwarding is canceled	[44]
45	Call forwarding not accepted Please check the destination number	[45]
46	Call screening enabled	[46]
47	Call transferred from the voice processing system	[47]
48	CALLBACK NUMBER	[48]
49	Caller ID (number)	[49], [277] [49], [278]
50	Caller ID number and caller name deleted	[50]
51	Caller ID number entries for this box are full, there are 30 entries for caller ID allowed	[51]
52	Caller ID number is (telephone number)	[52] [52], [722], [663]
53	Caller ID number is not assigned	[53] [53], [722], [432]
54	Caller ID numbers assigned	[601], [54]
55	Caller ID screen disabled	[55]
56	Caller ID screen enabled	[56]
57	Caller name is (name)	[57]
58	Caller name is erased	[58]
59	Caller name is not recorded	[59]
60	Calling the operator	[60], [467]
61	Cannot be retrieved	[61]

Table D-4

Prompt No.	Modifiable Prompts	Linked to Prompt No. (s)
62	Class of service number is (number)	[62], [643] [62], [644] [62]
63	Company greeting number (number)	[63], [178]
64	Company greeting number is (number)	[64]
65	Company name (name)	[65]
66	Company name erased	[66]
67	Counts cleared	[67]
68	Covering extension is (extension number)	[68]
69	Covering extension not assigned	[69]
70	Covering extension transfer disabled	[70]
71	Covering extension transfer enabled	[71]
72	Current company greeting setting is disabled	[72]
73	Current company greeting setting is number (number)	[73]
74	Current company greeting setting is System Greeting	[74]
75	Current service mode for Time Group number (number)	[75], [312] [75], [314] [75], [316] [75], [315] [75], [313] [75], [317]
76	Custom service menu	[76] [76], [178]
77	Custom service number (number)	[77]
78	Date is (date)	[78]
79	Day mode first operator's extension is (extension number)	[79]
80	Day mode first operator's extension is not assigned	[80]
81	Day mode second operator's extension is (extension number)	[81]

Table D-4

Prompt No.	Modifiable Prompts	Linked to Prompt No. (s)
82	Day mode second operator's extension is not assigned	[82]
83	Day mode third operator's extension is (extension number)	[83]
84	Day mode third operator's extension is not assigned	[84]
85	days	[85] [381], [85] [502], [85]
86	DECEMBER	[86]
87	Delay time is (time)	[87], [289], [374] [87], [289] [87], [374]
88	Delete message confirmation disabled	[88]
89	Delete message confirmation enabled	[89]
90	deleted	[329], [90]
91	Delivering message to (name)	[91]
92	Delivery list number is (number)	[92]
93	Department dialing menu erased	[93]
94	Department dialing menu is (menu)	[94]
95	Device notification for unreceived message disabled	[95]
96	Device notification for unreceived message enabled	[96]
97	Device number is (number)	[97]
98	DIAL TONE	[98]
99	digits	[151], [918], [99] [461], [918], [99] [461], [918], [99], [916] [139], [918], [99] [168], [918], [99]
100	Direct mailbox access disabled	[100]
101	Direct mailbox access enabled	[101]
102	EIGHT	[102]
103	EIGHT [HOUR]	[103]

Table D-4

Prompt No.	Modifiable Prompts	Linked to Prompt No. (s)
104	EIGHTEEN	[104]
105	EIGHTEEN [HOUR]	[105]
106	EIGHTEEN [MINUTE]	[106]
107	EIGHTEENTH	[107]
108	EIGHTH	[108]
109	EIGHTY	[109]
110	EIGHTY EIGHT	[110]
111	EIGHTY FIVE	[111]
112	EIGHTY FOUR	[112]
113	EIGHTY NINE	[113]
114	EIGHTY ONE	[114]
115	EIGHTY SEVEN	[115]
116	EIGHTY SIX	[116]
117	EIGHTY THREE	[117]
118	EIGHTY TWO	[118]
119	ELEVEN	[119]
120	ELEVEN [HOUR]	[120]
121	ELEVEN [MINUTE]	[121]
122	ELEVENTH	[122]
123	Enter 1 for AM, or 2 for PM	[123]
124	Enter a class of service number from 1 to 62	[124]
125	Enter a class of service number from 1 to 64	[125]
126	Enter a group number from 1 to 17	[126]
127	Enter a group number, 1 through 4	[127]
128	Enter a mailbox list number	[128]
129	Enter a message length from 1 to 6 minutes or 0 for unlimited length	[129]
130	Enter a message retention time up to 30 days	[130]
131	Enter a message retention time up to 30 days or 0 for unlimited days	[131]
132	Enter a personal greeting length from 8 to 60 seconds	[132]

Table D-4

Prompt No.	Modifiable Prompts	Linked to Prompt No. (s)
133	Enter delivery list number 1 or 2	[133]
134	Enter device number, 1 through 3	[134]
135	Enter extension number	[135]
136	Enter question number, followed by the hash sign	[136]
137	Enter question number, followed by the pound sign	[137]
138	Enter the 4 digits password	[138], [840] [138], [839]
139	Enter the caller ID number	[139], [918], [99]
140	Enter the caller name announcement number 1 through 120	[140]
141	Enter the company greeting number 1 through 32	[141]
142	Enter the custom service prompt number 1 through 100 To record custom service exit prompt, press 0	[142]
143	Enter the day of the month, followed by the hash sign	[143]
144	Enter the day of the month, followed by the pound sign	[144]
145	Enter the day, followed by the hash sign	[145]
146	Enter the day, followed by the pound sign	[146]
147	Enter the delay time, followed by the hash sign	[147]
148	Enter the delay time, followed by the pound sign	[148]
149	Enter the destination extension number for forwarding	[149]
150	Enter the destination mailbox number	[150], [752] [150], [751]
151	Enter the destination telephone number for forwarding	[151], [918], [99]
152	Enter the first 3 or 4 letters of the person's last name	[152], [221], [222] [152]

Table D-4

Prompt No.	Modifiable Prompts	Linked to Prompt No. (s)
153	Enter the first 4 letters of the owner's last name	[153]
154	Enter the interview mailbox number	[154]
155	Enter the last 2 digits of the year, followed by the hash sign	[155]
156	Enter the last 2 digits of the year, followed by the pound sign	[156]
157	Enter the mailbox number	[157] [157], [908] [157], [909]
158	Enter the maximum number of caller IDs for caller name announce Valid entries are from 0 to 30	[158]
159	Enter the maximum number of messages per mailbox Valid entries are from 5 to 100	[159]
160	Enter the month, followed by the hash sign	[160], [232]
161	Enter the month, followed by the pound sign	[161], [232]
162	Enter the new time, followed by the hash sign	[162], [232]
163	Enter the new time, followed by the pound sign	[163], [232]
164	Enter the operator's extension number	[164]
165	Enter the owner's extension number	[165]
166	Enter the port number	[166], [272]
167	Enter the prompt number	[167]
168	Enter the telephone number	[168], [918], [99]
169	Enter the telephone number and wait. To insert a pause or special command, enter the partial number and wait for the options menu	[169]
170	Enter the Time Group number 1 through 8	[170]
171	Enter the time, followed by the hash sign	[171], [232] [171], [740], [232]

Table D-4

Prompt No.	Modifiable Prompts	Linked to Prompt No. (s)
172	Enter the time, followed by the pound sign	[172], [232] [172], [741], [232]
173	Enter the total message time available per mailbox. Valid entries are from 5 to 100 minutes or 0 for unlimited time	[173]
174	Enter the trunk group number	[174], [272]
175	Enter your party's mailbox number	[175], [752] [175], [751]
176	Enter your password, followed by the hash sign	[176] [176], [839]
177	Enter your password, followed by the pound sign	[177] [177], [840]
178	erased	[63], [178] [76], [178]
179	Extension (extension number)	[179]
180	Extension number (extension number)	[180]
181	External delivery message for (name)	[181], [911], [26]
182	External delivery message scheduled for (name)	[182], [420], [19]
183	External delivery message scheduled on (date)	[183], [19]
184	External delivery message will be sent right away	[184]
185	External delivery message will be sent to (name)	[185], [500]
186	External message delivery disabled	[186]
187	External message delivery enabled	[187]
188	FAX messages	[920], [188]
189	FEBRUARY	[189]
190	FIFTEEN	[190]
191	FIFTEEN [HOUR]	[191]
192	FIFTEEN [MINUTE]	[192]
193	FIFTEENTH	[193]
194	FIFTH	[194]
195	FIFTY	[195]

Table D-4

Prompt No.	Modifiable Prompts	Linked to Prompt No. (s)
196	FIFTY [MINUTE]	[196]
197	FIFTY EIGHT	[197]
198	FIFTY EIGHT [MINUTE]	[198]
199	FIFTY FIVE	[199]
200	FIFTY FIVE [MINUTE]	[200]
201	FIFTY FOUR	[201]
202	FIFTY FOUR [MINUTE]	[202]
203	FIFTY NINE	[203]
204	FIFTY NINE [MINUTE]	[204]
205	FIFTY ONE	[205]
206	FIFTY ONE [MINUTE]	[206]
207	FIFTY SEVEN	[207]
208	FIFTY SEVEN [MINUTE]	[208]
209	FIFTY SIX	[209]
210	FIFTY SIX [MINUTE]	[210]
211	FIFTY THREE	[211]
212	FIFTY THREE [MINUTE]	[212]
213	FIFTY TWO	[213]
214	FIFTY TWO [MINUTE]	[214]
215	FIRST	[215]
216	First telephone number is (telephone number)	[216]
217	First telephone number is not assigned	[217]
218	FIVE	[218]
219	FIVE [HOUR]	[219]
220	for	[220] [365], [19], [220], [284] [365], [19], [220], [283] [360], [19], [220], [284]
221	For 'Q', press 7	[152], [221], [222]
222	For 'Z', press 9	[152], [221], [222]
223	For a system report, press 5	[798], [739], [728], [725], [223], [236], [746]

Table D-4

Prompt No.	Modifiable Prompts	Linked to Prompt No. (s)
224	For automated attendant status, press 4	[798], [739], [724], [224], [234], [236], [746] [798], [739], [724], [224], [234], [746]
225	For Day time, press 1 For Night time, press 2 For Lunch time, press 3 For Break time, press 4	[225]
226	For department dialing, press ✕	[462], [752], [226] [462], [751], [226]
227	For example, to enter 5 o'clock press 5 and the hash sign, or to enter 5:15 press 5, 1, 5 and the hash sign	[227]
228	For example, to enter 5 o'clock press 5 and the pound sign, or to enter 5:15 press 5, 1, 5 and the pound sign	[228]
229	For example, to enter January, press 1 and the hash sign	[229]
230	For example, to enter January, press 1 and the pound sign	[230]
231	For external message delivery, press 3	[231]
232	For help, press 0	[172], [232] [172], [741], [232] [804], [793], [756], [813], [846], [232] [804], [793], [756], [846], [232] [163], [232] [161], [232] [171], [232] [171], [740], [232] [162], [232] [160], [232]
233	For interview mailbox management, press 1	[233]
234	For mailbox management, press 5	[798], [739], [724], [224], [234], [236], [746] [798], [739], [724], [224], [234], [746]
235	For notification by telephone, press 1 For notification by beeper, press 2	[235]
236	For other features, press 6	[798], [739], [724], [224], [234], [236], [746] [798], [739], [728], [725], [223], [236], [746]
237	For Port setting, press 1 For Trunk service setting, press 2	[237]

Table D-4

Prompt No.	Modifiable Prompts	Linked to Prompt No. (s)
238	For the next name, press 2	[662], [238], [805], [748]
239	FORTY	[239]
240	FORTY [MINUTE]	[240]
241	FORTY EIGHT	[241]
242	FORTY EIGHT [MINUTE]	[242]
243	FORTY FIVE	[243]
244	FORTY FIVE [MINUTE]	[244]
245	FORTY FOUR	[245]
246	FORTY FOUR [MINUTE]	[246]
247	FORTY NINE	[247]
248	FORTY NINE [MINUTE]	[248]
249	FORTY ONE	[249]
250	FORTY ONE [MINUTE]	[250]
251	FORTY SEVEN	[251]
252	FORTY SEVEN [MINUTE]	[252]
253	FORTY SIX	[253]
254	FORTY SIX [MINUTE]	[254]
255	FORTY THREE	[255]
256	FORTY THREE [MINUTE]	[256]
257	FORTY TWO	[257]
258	FORTY TWO [MINUTE]	[258]
259	Forwarding mailbox number is (mailbox number)	[259]
260	Forwarding mailbox number is not assigned	[260]
261	Forwarding mode is copy	[261]
262	Forwarding mode is move	[262]
263	FOUR	[263]
264	FOUR [HOUR]	[264]
265	FOURTEEN	[265]
266	FOURTEEN [HOUR]	[266]
267	FOURTEEN [MINUTE]	[267]
268	FOURTEENTH	[268]

Table D-4

Prompt No.	Modifiable Prompts	Linked to Prompt No. (s)
269	FOURTH	[269]
270	FRIDAY	[270]
271	from (name)	[635], [271] [291], [271] [292], [271]
272	from 1 to	[166], [272] [174], [272]
273	Good afternoon	[273], [915] [273]
274	Good evening	[274], [915] [274]
275	Good morning	[275], [915] [275]
276	Greeting erased	[276]
277	greeting is (message)	[49], [277]
278	greeting is not recorded	[49], [278]
279	Group member deleted	[279]
280	Group name erased	[280]
281	Group name not recorded	[281]
282	Group number (number)	[282]
283	has been erased, because message retention time expired	[365], [19], [220], [283]
284	has not been received	[365], [19], [220], [284] [360], [19], [220], [284]
285	HASH(#)	[285]
286	Hello, this is the voice processing system	[286]
287	Hello, this is the voice processing system I have some information for the system Cooling fan has stopped functioning Please call for service	[287]
288	Hello, this is voice processing system with the following information More than 80 % of the disk space is now utilized Please erase unnecessary messages	[288]

Table D-4

Prompt No.	Modifiable Prompts	Linked to Prompt No. (s)
289	hours (time)	[87], [289], [374] [87], [289]
290	HUNDRED	[290]
291	I have a call for (name)	[291] [291], [271]
292	I have a call for mailbox (mailbox number)	[292] [292], [271]
293	I have a message for (name)	[293], [798], [775] [293], [798], [775], [301]
294	I was unable to reach (name)	[294]
295	I'll notify by beeper	[295]
296	I'll notify by telephone	[296]
297	I'll redial (number)	[297], [379]
298	I'll redial only once	[298]
299	If you are using a rotary telephone, stay on the line	[299], [678] [299]
300	If you really want to erase, press 1 If not, press 2	[300]
301	If you want me to call back later, press 3	[293], [798], [775], [301]
302	If you would like to hold, press 1	[302], [432]
303	Incorrect entry	[303]
304	Initialization completed	[304]
305	Initialization failed	[305]
306	Intercom paging disabled	[306]
307	Intercom paging enabled	[307]
308	Intercom paging group number is (number)	[308]
309	Interview mailbox number is (mailbox number)	[309]
310	Interview mailbox number is deleted	[310]
311	Interview mailbox number is not assigned	[311]
312	is Automatic mode	[75], [312]
313	is Manual Break mode	[75], [313]

Table D-4

Prompt No.	Modifiable Prompts	Linked to Prompt No. (s)
314	is Manual Day mode	[75], [314]
315	is Manual Lunch mode	[75], [315]
316	is Manual Night mode	[75], [316]
317	is PBX Control mode	[75], [317]
318	JANUARY	[318]
319	JULY	[319]
320	JUNE	[320]
321	Leaving a message is disabled	[321]
322	Leaving a message is enabled	[322]
323	Lunch Mode first operator's extension is (extension number)	[323]
324	Lunch Mode first operator's extension is not assigned	[324]
325	Lunch Mode second operator's extension is (extension number)	[325]
326	Lunch Mode second operator's extension is not assigned	[326]
327	Lunch Mode third operator's extension is (extension number)	[327]
328	Lunch Mode third operator's extension is not assigned	[328]
329	Mailbox	[329] [329], [90]
330	Mailbox is in use	[330]
331	Mailbox list label erased	[331]
332	Mailbox list number (number)	[332]
333	Mailbox number already specified	[333]
334	MARCH	[334]
335	Maximum number of caller IDs for caller name announce is (number)	[335]
336	Maximum number of messages per mailbox is (number)	[336]
337	MAY	[337]
338	(number) members maximum	[338]
339	Message back up disabled	[339]
340	Message back up enabled	[340]

Table D-4

Prompt No.	Modifiable Prompts	Linked to Prompt No. (s)
341	Message cancel for live call screening disabled	[341]
342	Message cancel for live call screening enabled	[342]
343	Message delivery canceled	[343]
344	Message erased	[344]
345	Message for (name)	[345], [483], [19]
346	Message from (name)	[346], [912], [19]
347	Message from the interview mailbox	[347]
348	Message from the Message Manager	[348]
349	Message from the System Manager	[349]
350	Message length is (time)	[350], [374]
351	Message length is unlimited	[351]
352	Message Manager	[352]
353	Message notification disabled	[353]
354	Message notification enabled	[354]
355	Message reception mode is interview mode	[355]
356	Message reception mode is message recording mode	[356]
357	Message reception mode is set to interview mode	[357]
358	Message reception mode is set to message recording mode	[358]
359	Message recorded by (mailbox number)	[359], [15], [14]
360	Message recorded on (date)	[360], [19] [360], [19], [220], [284]
361	Message retrieval order is first-in-first-out	[361]
362	Message retrieval order is last-in-first-out	[362]
363	Message scanning with information is disabled	[363]
364	Message scanning with information is enabled	[364]

Table D-4

Prompt No.	Modifiable Prompts	Linked to Prompt No. (s)
365	Message sent on (date)	[365], [19], [220], [284] [365], [19], [220], [283]
366	Message to (name)	[366], [33]
367	Message transferred via (mailbox number)	[367], [14]
368	Message waiting lamp notification disabled	[368]
369	Message waiting lamp notification enabled	[369]
370	Message waiting lamp notification for unreceived message disabled	[370]
371	Message waiting lamp notification for unreceived message enabled	[371]
372	Messages	[372] [920], [372]
373	(number) messages to verify	[373]
374	minutes	[374] [350], [374] [857], [374] [87], [289], [374] [87], [374]
375	MONDAY	[375]
376	more caller ID numbers	[917], [376]
377	more members	[917], [377]
378	MORE THAN ONE HUNDRED	[378]
379	more times	[297], [379]
380	New message	[380]
381	New message retention time is (day)	[381], [85]
382	new messages	[920], [382]
383	Night mode first operator's extension is (extension number)	[383]
384	Night mode first operator's extension is not assigned	[384]
385	Night mode second operator's extension is (extension number)	[385]
386	Night mode second operator's extension is not assigned	[386]

Table D-4

Prompt No.	Modifiable Prompts	Linked to Prompt No. (s)
387	Night mode third operator's extension is (extension number)	[387]
388	Night mode third operator's extension is not assigned	[388]
389	NINE	[389]
390	NINE [HOUR]	[390]
391	NINETEEN	[391]
392	NINETEEN [HOUR]	[392]
393	NINETEEN [MINUTE]	[393]
394	NINETEENTH	[394]
395	NINETY	[395]
396	NINETY EIGHT	[396]
397	NINETY FIVE	[397]
398	NINETY FOUR	[398]
399	NINETY NINE	[399]
400	NINETY ONE	[400]
401	NINETY SEVEN	[401]
402	NINETY SIX	[402]
403	NINETY THREE	[403]
404	NINETY TWO	[404]
405	NINTH	[405]
406	No answer greeting is (message)	[406]
407	No answer greeting is not recorded	[407]
408	No external delivery message pending	[408]
409	No letters have been specified	[409]
410	No messages to verify	[410]
411	No more messages	[411]
412	No one specified by this number	[412]
413	No previous message	[413]
414	No question recorded	[414]
415	NOVEMBER	[415]
416	O'CLOCK	[416]
417	OCTOBER	[417]

Table D-4

Prompt No.	Modifiable Prompts	Linked to Prompt No. (s)
418	of (company name)	[652], [418]
419	Old message	[419]
420	on (date)	[182], [420], [19]
421	ONE	[421]
422	ONE [HOUR]	[422]
423	One attempt was busy	[423]
424	One attempt was no answer	[424]
425	One attempt was successful	[425]
426	One message to verify	[426]
427	One other person is waiting to connect	[427]
428	Only extension call is available	[550], [428], [465]
429	Operator transfer disabled	[429]
430	Operator transfer enabled	[430]
431	(number) other people are waiting to connect	[431]
432	Otherwise, press 2	[753], [432] [783], [432] [591], [722], [432] [727], [432] [302], [432] [592], [722], [432] [730], [432] [807], [432] [729], [432] [53], [722], [432]
433	OWE	[433]
434	OWE EIGHT	[434]
435	OWE FIVE	[435]
436	OWE FOUR	[436]
437	OWE NINE	[437]
438	OWE ONE	[438]
439	OWE SEVEN	[439]
440	OWE SIX	[440]
441	OWE THREE	[441]

Table D-4

Prompt No.	Modifiable Prompts	Linked to Prompt No. (s)
442	OWE TWO	[442]
443	Owner's extension is (extension number)	[443]
444	Owner's extension is not assigned	[444]
445	Owner's extension number is deleted	[445]
446	Owner's name erased	[446]
447	Owner's name is (name)	[447]
448	Owner's name is deleted	[448]
449	Owner's name is not recorded	[449]
450	Password deleted	[450]
451	Password entry failure Check the password	[451]
452	Password is (number)	[452]
453	Password not assigned	[453]
454	PAUSE	[454]
455	Personal greeting for caller ID disabled	[455]
456	Personal greeting for caller ID enabled	[456]
457	Personal greeting length is (time)	[457], [507]
458	Play system prompt after personal greeting disabled	[458]
459	Play system prompt after personal greeting enabled	[459]
460	Please call (telephone number)	[460]
461	Please enter your callback number	[461], [918], [99] [461], [918], [99], [916]
462	Please enter your party's extension	[462], [752] [462], [752], [226] [462], [751] [462], [751], [226]
463	Please enter your party's mailbox number	[463], [752] [463], [752], [678] [463], [751] [463], [751], [678]
464	Please hold while I page your party	[464]

Table D-4

Prompt No.	Modifiable Prompts	Linked to Prompt No. (s)
465	Please inform System Manager	[559], [465] [550], [428], [465]
466	Please leave a message at the tone	[466]
467	Please wait a moment	[467] [60], [467]
468	PM	[468]
469	Port number is (number)	[469]
470	POUND(#)	[470]
471	Prompt mode for external message delivery is caller select	[471]
472	Prompt mode for external message delivery is system	[472]
473	Prompt mode for external message delivery is user 1	[473]
474	Prompt mode for external message delivery is user 2	[474]
475	Prompt mode is system	[475]
476	Prompt mode is user 1	[476]
477	Prompt mode is user 2	[477]
478	Prompt number (number)	[478]
479	Prompt restored	[479]
480	PULSE DIALING MODE	[480]
481	Question erased	[481]
482	Question number (number)	[482]
483	received on (date)	[345], [483], [19]
484	Record caller name at the tone	[484]
485	Record company name at the tone	[485]
486	Record greeting at the tone	[836]
487	Record label at the tone	[487]
488	Record menu at the tone	[488]
489	Record owner's name at the tone	[489]
490	Record the group name at the tone	[490]
491	Record the prompt at the tone	[491]
492	Record the question at the tone	[492]

Table D-4

Prompt No.	Modifiable Prompts	Linked to Prompt No. (s)
493	Record the recipient's name at the tone	[493]
494	Record your name at the tone	[494]
495	Recording accepted	[495]
496	Remote Call Forward to CO disabled	[496]
497	Remote Call Forward to CO enabled	[497]
498	Returning to top menu automated attendant service disabled	[498]
499	Returning to top menu automated attendant service enabled	[499]
500	right away	[185], [500]
501	SATURDAY	[501]
502	Saved message retention time is (day)	[502], [85]
503	Saved message retention time is unlimited	[503]
504	SECOND	[504]
505	Second telephone number is (telephone number)	[505]
506	Second telephone number is not assigned	[506]
507	seconds	[507] [16], [507] [457], [507]
508	Selection Menu	[508]
509	Selection menu erased	[509]
510	Selection menu is (selection menu)	[510]
511	Sending report now to terminal or printer connected to RS-232C port	[511]
512	SEPTEMBER	[512]
513	Set the answer length using the following options For 4 seconds, press 1 For 8 seconds, press 2 For 16 seconds, press 3 For 32 seconds, press 4	[513]
514	SEVEN	[514]
515	SEVEN [HOUR]	[515]

Table D-4

Prompt No.	Modifiable Prompts	Linked to Prompt No. (s)
516	SEVENTEEN	[516]
517	SEVENTEEN [HOUR]	[517]
518	SEVENTEEN [MINUTE]	[518]
519	SEVENTEENTH	[519]
520	SEVENTH	[520]
521	SEVENTY	[521]
522	SEVENTY EIGHT	[522]
523	SEVENTY FIVE	[523]
524	SEVENTY FOUR	[524]
525	SEVENTY NINE	[525]
526	SEVENTY ONE	[526]
527	SEVENTY SEVEN	[527]
528	SEVENTY SIX	[528]
529	SEVENTY THREE	[529]
530	SEVENTY TWO	[530]
531	SIX	[531]
532	SIX [HOUR]	[532]
533	SIXTEEN	[533]
534	SIXTEEN [HOUR]	[534]
535	SIXTEEN [MINUTE]	[535]
536	SIXTEENTH	[536]
537	SIXTH	[537]
538	SIXTY	[538]
539	SIXTY EIGHT	[539]
540	SIXTY FIVE	[540]
541	SIXTY FOUR	[541]
542	SIXTY NINE	[542]
543	SIXTY ONE	[543]
544	SIXTY SEVEN	[544]
545	SIXTY SIX	[545]
546	SIXTY THREE	[546]
547	SIXTY TWO	[547]
548	Sorry	[548]

Table D-4

Prompt No.	Modifiable Prompts	Linked to Prompt No. (s)
549	Sorry, I cannot add any more	[549]
550	Sorry, I cannot call this number	[550], [428], [465]
551	Sorry, mailbox in use, cannot be deleted	[551]
552	Sorry, maximum of 20 destinations exceeded	[552]
553	Sorry, no one is available to answer the call	[553]
554	Sorry, no space for recording	[554]
555	Sorry, Operator is not available to answer the call Please call back later	[555]
556	Sorry, there are no more matching names	[556] [556], [849]
557	Sorry, there is no space for recording	[557]
558	Sorry, there is no space for recording in this mailbox	[558]
559	Sorry, this function is not available	[559], [465] [559]
560	Sorry, this group is full	[560], [3] [560], [2]
561	Sorry, this line is busy	[561]
562	Sorry, this list is in use for delivery If this list is edited, all the deliveries will then be canceled	[562]
563	Sorry, this mailbox is in use	[563]
564	Sorry, this name cannot be found	[564]
565	Sorry, this number is not assigned	[565]
566	Sorry, this pager is not available	[566]
567	Sorry, this report is not available	[567]
568	Sorry, you cannot deliver the message The maximum number of delivery has already been reached	[568]
569	Sorry, you cannot reply	[569], [597] [569], [653] [569], [649]

Table D-4

Prompt No.	Modifiable Prompts	Linked to Prompt No. (s)
570	Sorry, you cannot transfer a private message	[570]
571	STAR(*)	[571]
572	State your comment at the tone	[572], [745], [789]
573	SUNDAY	[573]
574	Telephone number 1 for Remote Call Forward to CO is (telephone number)	[574]
575	Telephone number 1 for Remote Call Forward to CO is not assigned	[575]
576	Telephone number 1 is (telephone number)	[576]
577	Telephone number 1 is not assigned	[577]
578	Telephone number 2 for Remote Call Forward to CO is (telephone number)	[578]
579	Telephone number 2 for Remote Call Forward to CO is not assigned	[579]
580	Telephone number 2 is (telephone number)	[580]
581	Telephone number 2 is not assigned	[581]
582	Telephone number deleted	[582]
583	Telephone number is (telephone number)	[583]
584	Telephone number is not assigned	[584]
585	TEN	[585]
586	TEN [HOUR]	[586]
587	TEN [MINUTE]	[587]
588	TENTH	[588]
589	Thank you	[589]
590	Thank you for calling	[590]
591	The callback number is (telephone number)	[591], [722], [432]
592	The callback number is not assigned	[592], [722], [432]
593	The FAX transfer situation is as follows	[593]
594	The first 4 letters of the owner's last name are (name)	[594]

Table D-4

Prompt No.	Modifiable Prompts	Linked to Prompt No. (s)
595	The mailbox number entry failure Check the mailbox number	[595]
596	The message is (message)	[596]
597	The message sender is unknown	[569], [597]
598	The prompt is now turned off	[598]
599	The prompt is now turned on	[599]
600	The system-reserved mailbox cannot be edited	[600]
601	There are (number)	[601], [54]
602	There are no messages	[602]
603	There was one unsuccessful attempt to enter this mailbox	[603]
604	There were (number of failure)	[604], [905]
605	These are the brief segments of your Message	[605]
606	THIRD	[606]
607	Third telephone number is (telephone number)	[607]
608	Third telephone number is not assigned	[608]
609	THIRTEEN	[609]
610	THIRTEEN [HOUR]	[610]
611	THIRTEEN [MINUTE]	[611]
612	THIRTEENTH	[612]
613	THIRTIETH	[613]
614	THIRTY	[614]
615	THIRTY [MINUTE]	[615]
616	THIRTY EIGHT	[616]
617	THIRTY EIGHT [MINUTE]	[617]
618	THIRTY FIRST	[618]
619	THIRTY FIVE	[619]
620	THIRTY FIVE [MINUTE]	[620]
621	THIRTY FOUR	[621]
622	THIRTY FOUR [MINUTE]	[622]
623	THIRTY NINE	[623]

Table D-4

Prompt No.	Modifiable Prompts	Linked to Prompt No. (s)
624	THIRTY NINE [MINUTE]	[624]
625	THIRTY ONE	[625]
626	THIRTY ONE [MINUTE]	[626]
627	THIRTY SEVEN	[627]
628	THIRTY SEVEN [MINUTE]	[628]
629	THIRTY SIX	[629]
630	THIRTY SIX [MINUTE]	[630]
631	THIRTY THREE	[631]
632	THIRTY THREE [MINUTE]	[632]
633	THIRTY TWO	[633]
634	THIRTY TWO [MINUTE]	[634]
635	This call is for (name)	[635] [635], [271]
636	This call is from (name)	[636]
637	This caller ID number already exists	[637]
638	This device is for continuous use	[638]
639	This device is for scheduled use	[639]
640	This device is not to be used	[640]
641	This group has no members	[641]
642	This is a new mailbox	[642]
643	This is for Message Manager	[62], [643]
644	This is for System Manager	[62], [644]
645	This is the General Delivery Mailbox	[645]
646	This is the last message	[646]
647	This is the last prompt number	[647]
648	This is your mailbox	[648]
649	This is your message	[569], [649]
650	This list member already exists	[650]
651	This mailbox number is already assigned	[651]
652	This message is from (name)	[652], [418] [652]
653	This message is from the general delivery mailbox	[569], [653]

Table D-4

Prompt No.	Modifiable Prompts	Linked to Prompt No. (s)
654	This message will be delivered on (day)	[654], [19]
655	THOUSAND	[655]
656	THREE	[656]
657	THREE [HOUR]	[657]
658	THURSDAY	[658]
659	Time is (time)	[659]
660	times	[859], [660]
661	To accept the prompt, press 2	[819], [661], [755], [754]
662	To accept, press 1	[662], [238], [805], [748]
663	To accept, press 2	[819], [663], [755], [674], [754] [828], [663] [722], [663] [819], [663], [755] [712], [663], [820] [722], [663], [737] [722], [663], [759] [722], [663], [820], [668], [778], [830], [779] [722], [663], [820], [668], [778], [830], [779], [777] [722], [663], [808] [722], [663], [820], [668], [778], [779] [722], [663], [820], [668], [778], [779], [777] [52], [722], [663]
664	To accept, press 4	[672], [736], [820], [664] [853], [854], [855], [664]
665	To accept, press 5	[853], [854], [855], [782], [665]
666	To add group members, press 2	[690], [666] [690], [666], [732], [818]
667	To add more caller ID numbers, press 1	[667], [747]
668	To add more digits, press 4	[722], [663], [820], [668], [778], [830], [779] [722], [663], [820], [668], [778], [830], [779], [777] [722], [663], [820], [668], [778], [779] [722], [663], [820], [668], [778], [779], [777]
669	To add more members, press 1	[669], [747]
670	To add new mailbox number, press 3	[848], [670], [817] [848], [847], [670], [817]

Table D-4

Prompt No.	Modifiable Prompts	Linked to Prompt No. (s)
671	To add new member, press 1	[671] [671], [732], [820]
672	To add, press 1	[672] [672], [736], [820] [672], [736], [820], [664] [672], [723], [737], [821]
673	To add, press 2	[722], [673]
674	To add, press 4	[819], [663], [755], [674], [754]
675	To answer the call, press 1 Otherwise, press 2 and hang up	[675]
676	To assign or edit mailboxes, press 1 To delete mailboxes, press 2 To reset mailbox passwords, press 3	[676]
677	To call message sender, press 1 To record a message, press 2	[677]
678	To call the operator, press 0	[299], [678] [463], [752], [678] [678] [463], [751], [678]
679	To call this person, press 1	[679], [720], [849]
680	To cancel, press ✕ To continue, press 1	[680]
681	To cancel call forwarding, press 6	[761], [762], [764], [763], [765], [681] [761], [762], [764], [763], [681]
682	To cancel external message delivery, press 1	[682], [716]
683	To cancel holding, press 2 now Otherwise, I'll try your party again	[683]
684	To cancel mailing list review, press any key	[684]
685	To cancel this message or verification, press 3	[685]
686	To change caller ID greeting number 1, press 1 To change caller ID greeting number 2, press 2 To change caller ID greeting number 3, press 3 To change caller ID greeting number 4, press 4	[686]

Table D-4

Prompt No.	Modifiable Prompts	Linked to Prompt No. (s)
687	To change caller ID number, press 1 To change caller name, press 2 To accept, press 3	[687]
688	To change company greeting number, press 1 To set system greeting, press 2 To disable, press 3	[688]
689	To change company greeting setting, press 5	[837], [827], [834], [692], [689] [837], [827], [834], [692], [689], [776]
690	To change group name, press 1	[690], [666] [690], [666], [732], [818]
691	To change Remote Call Forwarding to CO setting, press 6	[709], [708], [706], [836], [698], [691]
692	To change service mode setting, press 4	[837], [827], [834], [692], [689] [837], [827], [834], [692], [689], [776]
693	To change Telephone number 1, press 1 To change Telephone number 2, press 2	[693]
694	To change the after hours greeting, press 3	[705], [696], [694] [705], [696], [694], [697]
695	To change the answer length, press 1	[695], [841], [842], [774]
696	To change the busy signal greeting, press 2	[705], [696], [694] [705], [696], [694], [697]
697	To change the caller ID greetings, press 4	[705], [696], [694], [697]
698	To change the caller name and number, press 5	[709], [708], [706], [836], [698] [709], [708], [706], [836], [698], [691]
699	To change the company greeting, press 1	[699], [700], [702], [701], [718], [786], [711], [714]
700	To change the company name, press 2	[699], [700], [702], [701], [718], [786], [711], [714]
701	To change the custom service menu, press 4	[699], [700], [702], [701], [718], [786], [711], [714] [702], [701], [718], [786], [711], [714]
702	To change the department dialing menu, press 3	[699], [700], [702], [701], [718], [786], [711], [714] [702], [701], [718], [786], [711], [714]

Table D-4

Prompt No.	Modifiable Prompts	Linked to Prompt No. (s)
703	To change the first telephone number, press 1 To change the second telephone number, press 2 To change the third telephone number, press 3	[703]
704	To change the message waiting lamp status, press 1 To change the device status, press 2 To assign the telephone or beeper numbers, press 3	[704]
705	To change the no answer greeting, press 1	[705], [696], [694] [705], [696], [694], [697]
706	To change the owner's name, press 3	[709], [708], [706], [836] [709], [708], [706], [836], [698] [709], [708], [706], [836], [698], [691]
707	To change the password, press 1	[707], [716]
708	To change the password, press 2	[715], [708], [710], [717] [709], [708], [706], [836] [709], [708], [706], [836], [698] [709], [708], [706], [836], [698], [691]
709	To change the personal greeting, press 1	[709], [708], [706], [836] [709], [708], [706], [836], [698] [709], [708], [706], [836], [698], [691]
710	To change the recipient's name, press 3	[715], [708], [710], [717]
711	To change the selection menu, press 7	[699], [700], [702], [701], [718], [786], [711], [714] [702], [701], [718], [786], [711], [714]
712	To change the setting, press 1	[712], [663], [820]
713	To change the specified prompt, press 1 To change all prompts, press 2	[713]
714	To change the system caller name announcement, press 8	[699], [700], [702], [701], [718], [786], [711], [714] [702], [701], [718], [786], [711], [714]
715	To change the telephone number, press 1	[715], [708], [710], [717]
716	To change the time and date, press 2	[707], [716] [682], [716]
717	To change the time and date, press 4	[715], [708], [710], [717]

Table D-4

Prompt No.	Modifiable Prompts	Linked to Prompt No. (s)
718	To change the voice label, press 5	[699], [700], [702], [701], [718], [786], [711], [714] [702], [701], [718], [786], [711], [714]
719	To change this question, press 1	[719], [841], [842], [774]
720	To change to the next person, press 2	[679], [720], [849]
721	To change user prompt 1, press 1 To change user prompt 2, press 2	[721]
722	To change, press 1	[722], [663] [591], [722], [432] [592], [722], [432] [722], [663], [737] [722], [663], [759] [722], [663], [820], [668], [778], [830], [779] [722], [663], [820], [668], [778], [830], [779], [777] [722], [673] [722], [663], [808] [722], [663], [820], [668], [778], [779] [722], [663], [820], [668], [778], [779], [777] [53], [722], [432] [52], [722], [663] [722], [843] [722], [843], [850] [722], [843], [851]
723	To change, press 2	[672], [723], [737], [821]
724	To check the mailbox distribution, press 3	[798], [739], [724], [224], [234], [236], [746] [798], [739], [724], [224], [234], [746]
725	To check the mailbox distribution, press 4	[798], [739], [728], [725], [223], [236], [746]
726	To clear all mailbox usage counts, press 2	[844], [726]
727	To continue holding, press 1	[727], [432]
728	To customize your mailbox, press 3	[845], [838], [728], [835], [785], [746] [845], [838], [728], [835], [785], [832], [746] [798], [739], [728], [725], [223], [236], [746]
729	To delete all caller ID numbers, press 1	[729], [432]
730	To delete all group members, press 1	[730], [432]
731	To delete distribution verification of this message, press 1 To cancel message delivery, press 2	[731]

Table D-4

Prompt No.	Modifiable Prompts	Linked to Prompt No. (s)
732	To delete group members, press 3	[690], [666], [732], [818]
733	To delete members, press 2	[671], [733], [820]
734	To delete the password, press 1	[734], [780]
735	To delete, press 1	[735], [795] [735], [792] [735], [780]
736	To delete, press 2	[672], [736], [820] [672], [736], [820], [664]
737	To delete, press 3	[722], [663], [737] [672], [723], [737], [821]
738	To deliver a broadcast message, press 1	[738], [739]
739	To deliver a message, press 2	[798], [739], [724], [224], [234], [236], [746] [798], [739], [724], [224], [234], [746] [798], [739], [728], [725], [223], [236], [746] [738], [739]
740	To deliver now, press only the hash sign	[171], [740], [232]
741	To deliver now, press only the pound sign	[172], [741], [232]
742	To enable call blocking, press 1 To enable call screening, press 2 To enable intercom paging, press 3 To enable beeper access, press 4 To disable all transfer service, press 5	[742]
743	To end recording, hang up To cancel your message, press *, if you have a touchtone phone	[743]
744	To end recording, hang up or press 1 for more features	[744], [789]
745	To end recording, press 1	[745], [789] [745] [572], [745], [789]

Table D-4

Prompt No.	Modifiable Prompts	Linked to Prompt No. (s)
746	To end this call, press *	[804], [812], [746] [804], [812], [822], [760], [746] [807], [746] [798], [739], [724], [224], [234], [236], [746] [798], [739], [724], [224], [234], [746] [845], [838], [728], [835], [785], [746] [845], [838], [728], [835], [785], [833], [746] [798], [739], [728], [725], [223], [236], [746]
747	To end, press 2	[669], [747] [667], [747]
748	To enter a new name or mailbox, press *	[662], [238], [805], [748]
749	To enter another extension, press *	[749]
750	To enter another extension, press 2	[781], [750]
751	To enter by name, press the hash sign and 1	[463], [751] [463], [751], [678] [463], [751], [226] [175], [751] [150], [751]
752	To enter by name, press the pound sign and 1	[463], [752] [463], [752], [678] [462], [752] [462], [752], [226] [175], [752] [150], [752]
753	To enter your callback number, press 1	[753], [432]
754	To erase and exit, press *	[819], [663], [755], [674], [754] [819], [661], [755], [754]
755	To erase and try again, press 3	[819], [663], [755], [674], [754] [819], [661], [755], [754] [819], [663], [755]
756	To erase this message, press 3	[804], [793], [756], [813], [846], [232] [804], [811], [793], [756], [813], [822], [760], [846], [784] [804], [793], [756], [846], [232] [804], [811], [793], [756], [822], [760], [846], [784]

Table D-4

Prompt No.	Modifiable Prompts	Linked to Prompt No. (s)
757	To erase this prompt and use system prompt, press 2	[801], [757], [850] [801], [757], [851]
758	To erase this question, press 1	[758], [841], [842], [774]
759	To erase, press 3	[722], [663], [759]
760	To fast forward, press 6	[804], [812], [822], [760], [746] [804], [811], [793], [756], [813], [822], [760], [846], [784] [804], [811], [793], [756], [822], [760], [846], [784]
761	To forward all calls, press 1	[761], [762], [764], [763], [765], [681] [761], [762], [764], [763], [681]
762	To forward busy calls, press 2	[761], [762], [764], [763], [765], [681] [761], [762], [764], [763], [681]
763	To forward busy or no answer calls, press 4	[761], [762], [764], [763], [765], [681] [761], [762], [764], [763], [681]
764	To forward no answer calls, press 3	[761], [762], [764], [763], [765], [681] [761], [762], [764], [763], [681]
765	To forward to a CO line, press 5	[761], [762], [764], [763], [765], [681]
766	To forward to the other number, press 3	[766]
767	To forward to your telephone number 1, press 1	[767]
768	To forward to your telephone number 2, press 2	[768]
769	To generate disk usage report, press 1 To clear disk usage counts, press 2	[769]
770	To generate fax call report, press 1 To clear fax call counts, press 2	[770]
771	To generate mailbox usage report, press 1 To clear mailbox usage counts, press 2	[771]
772	To generate port usage report, press 1 To clear port usage counts, press 2	[772]

Table D-4

Prompt No.	Modifiable Prompts	Linked to Prompt No. (s)
773	To generate system service report, press 1 For disk usage report management, press 2 For port usage report management, press 3 For mailbox usage report management, press 4 To generate mailbox parameter report, press 5 To generate call account report, press 6 To generate class of service parameter report, press 7 To generate fax call report, press 8	[773]
774	To go directly to a question, press 4	[695], [841], [842], [774] [719], [841], [842], [774] [758], [841], [842], [774] [841], [842], [774]
775	To hold this call, press 2	[293], [798], [775] [293], [798], [775], [301]
776	To initialize internal modem, press 6	[837], [827], [834], [692], [689], [776]
777	To insert a beeper display command, press 8	[722], [663], [820], [668], [778], [830], [779], [777] [722], [663], [820], [668], [778], [779], [777]
778	To insert a pause, press 5	[722], [663], [820], [668], [778], [830], [779] [722], [663], [820], [668], [778], [830], [779], [777] [722], [663], [820], [668], [778], [779] [722], [663], [820], [668], [778], [779], [777]
779	To insert a wait for dial tone, press 7	[722], [663], [820], [668], [778], [830], [779] [722], [663], [820], [668], [778], [830], [779], [777] [722], [663], [820], [668], [778], [779] [722], [663], [820], [668], [778], [779], [777]
780	To keep, press 2	[735], [780] [734], [780]
781	To leave a message, press 1	[781] [781], [750]
782	To let the caller select prompt language, press 4	[853], [854], [855], [782], [665]
783	To make this message private, press 1	[783], [432]

Table D-4

Prompt No.	Modifiable Prompts	Linked to Prompt No. (s)
784	To message scan, press 8	[804], [811], [793], [756], [813], [822], [760], [846], [784] [804], [811], [793], [756], [822], [760], [846], [784]
785	To modify message, press 5	[845], [838], [728], [835], [785], [746] [845], [838], [728], [835], [785], [833], [746]
786	To modify the user prompt, press 6	[699], [700], [702], [701], [718], [786], [711], [714] [702], [701], [718], [786], [711], [714]
787	To notify your party's beeper, press 4	[787]
788	To page your party, press 3	[788]
789	To pause and restart recording, press 2	[745], [789] [744], [789] [789] [572], [745], [789]
790	To play the entire message, press 3	[810], [793], [790]
791	To play the message, press 1 To check the previous message, press 1 twice To check the next message, press 2	[791]
792	To play the next caller ID number, press 2	[735], [792]
793	To play the next message, press 2	[804], [793], [756], [813], [846], [232] [804], [811], [793], [756], [813], [822], [760], [846], [784] [810], [793], [790] [804], [793], [756], [846], [232] [804], [811], [793], [756], [822], [760], [846], [784] [811], [793] [793]
794	To play the next schedule, press 2	[815], [794], [806], [796] [794], [806], [796]
795	To play the next, press 2	[735], [795]
796	To play the previous schedule, press 4	[815], [794], [806], [796] [794], [806], [796]
797	To reach the covering extension, press 2	[797]

Table D-4

Prompt No.	Modifiable Prompts	Linked to Prompt No. (s)
798	To receive the message, press 1	[293], [798], [775] [293], [798], [775], [301] [798], [739], [724], [224], [234], [236], [746] [798], [739], [724], [224], [234], [746] [798], [739], [728], [725], [223], [236], [746]
799	To record a message for external delivery, press 1 To check external delivery message status, press 2 To set up mailing list, press 3	[799]
800	To record a message, press 1 To add new mailbox number, press 2 To review the mailing list, press 3	[800]
801	To record a new prompt, press 1	[801], [757], [850] [801], [757], [851]
802	To record the question, press 1 To set the answer length, press 2 To erase the question, press 3	[802]
803	To record, press 1 To erase, press 2	[803]
804	To repeat this message, press 1	[804], [812], [746] [804], [812], [822], [760], [746] [804], [793], [756], [813], [846], [232] [804], [811], [793], [756], [813], [822], [760], [846], [784] [804], [793], [756], [846], [232] [804], [811], [793], [756], [822], [760], [846], [784]
805	To repeat this name, press 3	[662], [238], [805], [748]
806	To repeat this schedule, press 3	[815], [794], [806], [796] [794], [806], [796]
807	To repeat, press 1	[807], [746] [807], [432]
808	To repeat, press 3	[722], [663], [808]
809	To replay the previous message information, press 1 To play the next message's information, press 2 To play the message, press 3	[809]
810	To replay the previous message, press 1	[810], [793], [790]

Table D-4

Prompt No.	Modifiable Prompts	Linked to Prompt No. (s)
811	To replay the previous message, press 1 twice	[804], [811], [793], [756], [813], [822], [760], [846], [784] [804], [811], [793], [756], [822], [760], [846], [784] [811], [793] [811]
812	To reply, press 2	[804], [812], [746] [804], [812], [822], [760], [746]
813	To reply, press 4	[804], [793], [756], [813], [846], [232] [804], [811], [793], [756], [813], [822], [760], [846], [784]
814	To report all mailbox usage, press 2	[844], [814]
815	To reschedule, press 1	[815], [794], [806], [796]
816	To retrieve the call, press 2	[816]
817	To review the mailing list, press 4	[848], [670], [817] [848], [847], [670], [817]
818	To review this group, press 4	[690], [666], [732], [818]
819	To review, press 1	[819], [663], [755], [674], [754] [819], [661], [755], [754] [819], [663], [755]
820	To review, press 3	[671], [733], [820] [712], [663], [820] [722], [663], [820], [668], [778], [830], [779] [722], [663], [820], [668], [778], [830], [779], [777] [722], [663], [820], [668], [778], [779] [722], [663], [820], [668], [778], [779], [777] [672], [736], [820] [672], [736], [820], [664]
821	To review, press 4	[672], [723], [737], [821]
822	To rewind, press 5	[804], [812], [822], [760], [746] [804], [811], [793], [756], [813], [822], [760], [846], [784] [804], [811], [793], [756], [822], [760], [846], [784]

Table D-4

Prompt No.	Modifiable Prompts	Linked to Prompt No. (s)
823	To select caller select mode, press 1 To select without message mode, press 2 To select before message recording mode, press 3 To select after message recording mode, press 4 To disable all entry modes, press 5 To accept, press 6	[823]
824	To send to 1 recipient, press 1 To send by mailing list, press 2	[824]
825	To set Automatic mode, press 1 To set Manual Day mode, press 2 To set Manual Night mode, press 3 To set Manual Lunch mode, press 4 To set Manual Break mode, press 5 To set PBX Control mode, press 6	[825]
826	To set call transfer status, press 1 To set up covering extension, press 2 To set message reception mode, press 3 To set incomplete handling status, press 4	[826]
827	To set class of service, press 2	[837], [827], [834] [837], [827], [834], [692], [689] [837], [827], [834], [692], [689], [776]
828	To set delivery time or make this message private, press 1	[828], [663]
829	To set delivery time, press 1 For immediate delivery, press 2	[829]
830	To set dial mode, press 6	[722], [663], [820], [668], [778], [830], [779] [722], [663], [820], [668], [778], [830], [779], [777]
831	To set leaving a message status, press 1 To set covering extension transfer status, press 2 To set intercom paging status, press 3 To set beeper access status, press 4 To set operator transfer status, press 5 To set returning to top menu automated attendant service status, press 6	[831]
832	To set station call forwarding, press 4	[832]

Table D-4

Prompt No.	Modifiable Prompts	Linked to Prompt No. (s)
833	To set station call forwarding, press 6	[845], [838], [728], [835], [785], [833], [746]
834	To set the clock, press 3	[837], [827], [834] [837], [827], [834], [692], [689] [837], [827], [834], [692], [689], [776]
835	To set the clock, press 4	[845], [838], [728], [835], [785], [746] [845], [838], [728], [835], [785], [833], [746]
836	To set the group distribution lists, press 4	[709], [708], [706], [836] [709], [708], [706], [836], [698] [709], [708], [706], [836], [698], [691]
837	To set up mailbox, press 1	[837], [827], [834] [837], [827], [834], [692], [689] [837], [827], [834], [692], [689], [776]
838	To set up message waiting notification, press 2	[838] [845], [838], [728], [835], [785], [746] [845], [838], [728], [835], [785], [832], [746]
839	To skip setting the password, press the hash sign	[138], [839] [176], [839]
840	To skip setting the password, press the pound sign	[138], [840] [177], [840]
841	To skip to the next question, press 2	[695], [841], [842], [774] [719], [841], [842], [774] [758], [841], [842], [774] [841], [842], [774]
842	To skip to the previous question, press 3	[695], [841], [842], [774] [719], [841], [842], [774] [758], [841], [842], [774] [841], [842], [774]
843	To skip, press 2	[722], [843] [722], [843], [850] [722], [843], [851]
844	To specify the mailbox range, press 1	[844], [814] [844], [726]
845	To transfer General Delivery Mailbox messages, press 1	[845], [838], [728], [835], [785], [746] [845], [838], [728], [835], [785], [833], [746]

Table D-4

Prompt No.	Modifiable Prompts	Linked to Prompt No. (s)
846	To transfer this message, press 7	[804], [793], [756], [813], [846], [232] [804], [811], [793], [756], [813], [822], [760], [846], [784] [804], [793], [756], [846], [232] [804], [811], [793], [756], [822], [760], [846], [784]
847	To transfer with comment, press 2	[848], [847], [670], [817]
848	To transfer, press 1	[848], [670], [817] [848], [847], [670], [817]
849	To try again, press ✕	[679], [720], [849] [556], [849]
850	To turn off the prompt, press 3	[801], [757], [850] [722], [843], [850]
851	To turn on the prompt, press 3	[801], [757], [851] [722], [843], [851]
852	To use for scheduling, press 1 To use continuously, press 2 To use not at all, press 3	[852]
853	To use the system prompt, press 1	[853], [854], [855], [664] [853], [854], [855], [782], [665]
854	To use user 1 prompt, press 2	[853], [854], [855], [664] [853], [854], [855], [782], [665]
855	To use user 2 prompt, press 3	[853], [854], [855], [664] [853], [854], [855], [782], [665]
856	TONE DIALING MODE	[856]
857	Total message time available per mailbox is (time)	[857], [374]
858	Total message time available per mailbox is unlimited	[858]
859	Transferred (number)	[859], [660]
860	Transferred 1 time	[860]
861	Trunk group number is (number)	[861]
862	TUESDAY	[862]
863	TWELFTH	[863]
864	TWELVE	[864]
865	TWELVE [HOUR]	[865]
866	TWELVE [MINUTE]	[866]

Table D-4

Prompt No.	Modifiable Prompts	Linked to Prompt No. (s)
867	TWENTY	[867]
868	TWENTY [HOUR]	[868]
869	TWENTY [MINUTE]	[869]
870	TWENTY EIGHT	[870]
871	TWENTY EIGHT [MINUTE]	[871]
872	TWENTY EIGHTH	[872]
873	TWENTY FIFTH	[873]
874	TWENTY FIRST	[874]
875	TWENTY FIVE	[875]
876	TWENTY FIVE [MINUTE]	[876]
877	TWENTY FOUR	[877]
878	TWENTY FOUR [HOUR]	[878]
879	TWENTY FOUR [MINUTE]	[879]
880	TWENTY FOURTH	[880]
881	TWENTY NINE	[881]
882	TWENTY NINE [MINUTE]	[882]
883	TWENTY NINTH	[883]
884	TWENTY ONE	[884]
885	TWENTY ONE [HOUR]	[885]
886	TWENTY ONE [MINUTE]	[886]
887	TWENTY SECOND	[887]
888	TWENTY SEVEN	[888]
889	TWENTY SEVEN [MINUTE]	[889]
890	TWENTY SEVENTH	[890]
891	TWENTY SIX	[891]
892	TWENTY SIX [MINUTE]	[892]
893	TWENTY SIXTH	[893]
894	TWENTY THIRD	[894]
895	TWENTY THREE	[895]
896	TWENTY THREE [HOUR]	[896]
897	TWENTY THREE [MINUTE]	[897]
898	TWENTY TWO	[898]
899	TWENTY TWO [HOUR]	[899]

Table D-4

Prompt No.	Modifiable Prompts	Linked to Prompt No. (s)
900	TWENTY TWO [MINUTE]	[900]
901	TWENTIETH	[901]
902	TWO	[902]
903	TWO [HOUR]	[903]
904	TWO THOUSAND	[904]
905	unsuccessful attempts to enter this mailbox	[604], [905]
906	Use call waiting on busy signal disabled	[906]
907	Use call waiting on busy signal enabled	[907]
908	Use the hash sign key as a wild card character	[157], [908]
909	Use the pound sign key as a wild card character	[157], [909]
910	Verification deleted	[910]
911	was erased	[181], [911], [26]
912	was sent on (date)	[346], [912], [19]
913	WEDNESDAY	[913]
914	Welcome to the general delivery mailbox	[914]
915	Welcome to the Voice Processing System	[275], [915] [273], [915] [274], [915] [915]
916	When you are finished, hang up, or stay on the line to confirm or change your number	[461], [918], [99], [916]
917	You can add up to (number)	[917], [377] [917], [376]
918	You can enter up to (number)	[151], [918], [99] [461], [918], [99] [461], [918], [99], [916] [139], [918], [99] [168], [918], [99]
919	You can not add any more digits	[919]

Table D-4

Prompt No.	Modifiable Prompts	Linked to Prompt No. (s)
920	You have (number)	[920], [382] [920], [372] [920], [188]
921	You have a call	[921]
922	You have a call from (name)	[922]
923	You have 1 FAX message	[923]
924	You have 1 message	[924]
925	You have 1 new message	[925]
926	Your extension is call forwarded all calls to extension (extension)	[926]
927	Your extension is call forwarded busy calls to extension (extension)	[927]
928	Your extension is call forwarded busy or no answer calls to extension (extension)	[928]
929	Your extension is call forwarded no answer calls to extension (extension)	[929]
930	Your extension is call forwarded to telephone number (telephone number)	[930]
931	ZERO	[931]
932	Caller ID Callback is enabled	[932]
933	Caller ID Callback is disabled	[933]
934	Toll Saver is disabled	[934]
935	Toll Saver for DID	[935]
936	Toll Saver for Caller ID	[936]
937	To disable Toll Saver, press 1 For DID, press 2 For Caller ID, press 3 To accept, press 4	[937]
938	To change the Number for Toll Saver, press 7	[709], [708], [706], [836], [698], [691], [938], [939]
939	To change the personal custom service, press 8	[709], [708], [706], [836], [698], [691], [938], [939]
940	To change Caller ID Number 1, press 1 To change Caller ID Number 2, press 2	[940]

Table D-4

Prompt No.	Modifiable Prompts	Linked to Prompt No. (s)
941	Caller ID Number 1 is not assigned	[941]
942	Caller ID Number 2 is not assigned	[942]
943	Caller ID Number 1 is (number)	[943]
944	Caller ID Number 2 is (number)	[944]
945	DID Number is not assigned	[945]
946	DID Number is (number)	[946]
947	Enter the number for Toll Saver	[947], [918], [99]
948	This number is already assigned	[948]
949	Number deleted	[949]
950	To change the key assignment, press 1 To review current setting, press 2	[950]
951	To enter the key number you want to change from 3 to 9 If you want to change No DTMF Input operation, press 1	[951]
952	Key (number)	[952], [953] [952], [954] [952], [955] [952], [956] [952], [957] [952], [958] [952], [968]
953	is not assigned	[952], [953]
954	is transfer to mailbox (mailbox number)	[952], [954]
955	is transfer to extension (extension number)	[952], [955]
956	is Custom Service number (number)	[952], [956]
957	is Voice Mail Service	[952], [957]
958	is Call Transfer Service	[952], [958]
959	Enter the custom service number 1 through 100	[959]
960	No DTMF Input operation is Message Recording	[960]
961	No DTMF Input operation is Disconnect	[961]

Table D-4

Prompt No.	Modifiable Prompts	Linked to Prompt No. (s)
962	To assign transfer to mailbox, press 1	[962], [963], [964], [965], [966], [967] [962], [963], [965], [966], [967]
963	To assign transfer to extension, press 2	[962], [963], [964], [965], [966], [967] [962], [963], [965], [966], [967]
964	To assign transfer to outside telephone, press 3	[962], [963], [964], [965], [966], [967]
965	To assign custom service, press 4	[962], [963], [964], [965], [966], [967] [962], [963], [965], [966], [967]
966	To assign voice mail service, press 5	[962], [963], [964], [965], [966], [967] [962], [963], [965], [966], [967]
967	To assign call transfer service, press 6	[962], [963], [964], [965], [966], [967] [962], [963], [965], [966], [967]
968	is transfer to outside telephone number (telephone number)	[952], [968]
969	You cannot assign more than two outside transfer	[969]
970	Key assignment is cancelled	[970]
971	To cancel, press 3	[722], [663], [971]
972	Subscriber Tutorial enabled	[972]
973	Subscriber Tutorial disabled	[973]
974	To save this message as new, press 9	[804], [811], [793], [756], [822], [760], [846], [784], [974] [804], [811], [793], [756], [813], [822], [760], [846], [784], [974]
975	To change Port or Trunk setting, press 5	[837], [827], [834], [692], [975] [837], [827], [834], [692], [975], [776]
976	To set up mailbox, press 1 To set class of service, press 2 To set the clock, press 3 To change service mode setting, press 4 To change Port or Trunk setting, press 5	[976]
977	To change Company Greeting setting, press 1 To change Incoming Call Service setting, press 2	[977]
978	Current Incoming Call Service is Voice Mail Service	[978]

D9 LIST OF MODIFIABLE PROMPTS

Table D-4

Prompt No.	Modifiable Prompts	Linked to Prompt No. (s)
979	Current Incoming Call Service is Automated Attendant Service	[979]
980	Current Incoming Call Service is Custom Service number (number)	[980]
981	Current Incoming Call Service is Interview Mailbox (mailbox number)	[981]
982	Current Incoming Call Service is disabled	[982]
983	To set Voice Mail Service, press 1 To set Automated Attendant Service, press 2 To set Custom Service, press 3 To set Interview Service, press 4 To disable, press 5	[983]
984	To set Voice Mail Service, press 1 To set Automated Attendant Service, press 2 To set Custom Service, press 3 To set Interview Service, press 4	[984]
985	Envelope Information Position is Before	[985]
986	Envelope Information Position is After	[986]
987	Envelope Information Position is disabled	[987]
988	To set "Before", press 1 To set "After", press 2 To disable, press 3 To accept, press 4	[988]
989	Time and Date Stamp Position is Before	[989]
990	Time and Date Stamp Position is After	[990]
991	Time and Date Stamp Position is disabled	[991]
992	To enable call blocking, press 1 To enable call screening, press 2 To enable intercom paging, press 3 To enable beeper access, press 4 To enable transfer to mailbox, press 5 To disable all transfer service, press 6	[992]

Table D-4

Prompt No.	Modifiable Prompts	Linked to Prompt No. (s)
993	Transfer to mailbox enabled	[993]
994	To generate system service report, press 1 For disk usage report management, press 2 For port usage report management, press 3 For mailbox usage report management, press 4 To generate mailbox parameter report, press 5 For call account report management, press 6 To generate class of service parameter report, press 7 To generate fax call report, press 8	[994]
995	To generate call account report, press 1 To clear call account report, press 2	[995]
996	Report cleared	[996]
997	Now, trying to reach next operator	[997]
998	New message retention time is unlimited	[998]
999	You cannot access this Service	[999]
1000	Call Transfer to Outside is enabled	[1000]
1001	Call Transfer to Outside is disabled	[1001]
1002	To set call transfer status, press 1 To set up covering extension, press 2 To set message reception mode, press 3 To set incomplete handling status, press 4 To set telephone number for transfer, press 5	[1002]
1003	System Manager	[1003]
1004	Call Forwarding Cancel is not accepted Please check the destination number	[1004]
1005	To forward to some other number, press 3	[1005]

Table D-4

Prompt No.	Modifiable Prompts	Linked to Prompt No. (s)
1006	To confirm your settings, press 1 To enter subscriber's service, press 2 To end this call, press *	[1006]
1007	Welcome to the Panasonic Voice Mail System This is the Subscriber Tutorial service In this service, you can set your password, record your name and record your personal greetings before you use this system You can hear a Help message before each setup	[1007]
1008	You can set your password to a maximum of 10 digits When you access your subscriber service the system asks you to enter your password We recommend you change your password frequently for good security	[1008]
1009	Please record your name It is used in the following way If you deliver your message to another mailbox owner by using message delivery feature, the message receiver will hear your message with your name when he receives the message	[1009]

Table D-4

Prompt No.	Modifiable Prompts	Linked to Prompt No. (s)
1010	<p>When any caller leaves a message for your mailbox, your Personal Greeting is played before the recording</p> <p>There are three kinds of Personal Greetings</p> <p>A No Answer Greeting is played when you cannot answer a call</p> <p>A Busy Greeting is played when you are on another call</p> <p>An After Hours Greeting is played when you are gone for the day</p> <p>Please record these personal greetings based on following system greeting</p> <p>If you do not record a Personal Greeting, the system plays the following pre-recorded system greeting</p> <p>Please leave a message at the tone</p> <p>To end recording, hang up or press 1 for more features</p> <p>To pause and restart recording, press 2</p> <p>Refer to the system greeting, but record your Personal Greeting as you like</p>	[1010]

[Linked Prompts List]

Subscriber Service

Table D-5

[920]	You have (number)	[604]	There were (number of failure)
[380]	new message	[905]	unsuccessful attempts to enter this mailbox

Receive Message

Table D-6

[359] Message recorded by (mailbox number)	[367] Message transferred via (mailbox number)
[15] and transferred via (mailbox number)	[14] and (mailbox number)
[14] and (mailbox number)	
[360] Message recorded on (date)	[920] You have (number)
[19] at (time)	[372] Messages

Message Scan

Table D-7

[346] Message from (name)	
[912] was sent on (date)	
[19] at (time)	

Message Delivery

Table D-8

[654] This message will be delivered on (day)	
[19] at (time)	

Personal Group Distribution List

Table D-9

[917] You can add up to (number)	
[377] more members	

Check Mailbox Distribution

Table D-10

[345] Message for (name)	[365] Message sent on (date)
[483] received on (date)	[19] at (time)
[19] at (time)	[220] for (mailbox number)
[220] for (mailbox number)	[283] has been erased, because message retention time expired
[284] has not been received	

External Message Delivery

Table D-11

[182]	External delivery message scheduled for (name)	[652]	This message is from (name)
[420]	on (date)	[418]	of (company name)
[19]	at (time)	[181]	External delivery message for (name)
[185]	External delivery message will be sent to (name)	[911]	was erased
[500]	right away	[26]	because message retention time expired
[366]	Message to (name)	[297]	I'll redial (number)
[33]	being delivered now	[379]	more times

Message Waiting Notification

Table D-12

[461]	Please enter your callback number	[461]	Please enter your callback number
[918]	You can enter up to (number)	[918]	You can enter up to (number)
[99]	digits	[99]	digits
		[916]	When you are finished hang up, stay on the line to confirm or change your number
[635]	This call is for (name)		
[271]	from (name)		

Interview Mailbox Management

Table D-13

[16]	Answer length is (number)		
[507]	seconds		

Fax Management

Table D-14

[920]	You have (number)	[859]	Transferred (number)
[188]	FAX messages	[660]	times

Alternate Extension Group

Transfers the call coming into the extensions in this group following the sequence specified by "Alternate Extension Transfer Sequence".

Auto Configuration

(Available with DPT Integration only.) The VPS can automatically draw information from the KX-TD500, the KX-TD816, the KX-TD1232, the KX-TA1232, the KX-TD308, or the KX-TDA/KX-TAW series. This information includes, among other things, extension number assignments for each VPS port. This saves time in the initial setup. Auto Configuration can be executed by DIP/Rotary Switch settings or by System Administration (Quick Setup).

Auto Forwarding

Allows unretrieved messages to be copied or moved to another mailbox.

Automated Attendant

The Automated Attendant feature of the VPS requests the caller to enter an extension number and then the VPS dials the number. If there is no answer or the line is busy, the caller is given some options, including the option to leave a message in a mailbox. This is the advantage of calling an extension indirectly through the Automated Attendant rather than calling it directly.

Call Blocking

Connects the caller to the Incomplete Call Handling Service without ringing the subscriber's extension.

Call Screening

Allows subscribers to screen calls. The VPS prompts the caller with the message "Record your name at the tone", and records the caller's name; it then puts the caller on hold while playing the name to the subscriber who decides whether to take the call or not.

Call Transfer

Transfers a call to the requested destination.

Called Party ID

(Sometimes referred to as Follow-On ID) Allows the PBX to dial extra digits to bring the caller directly to a specified mailbox, rather than to the General Delivery Mailbox.

Caller ID Callback

Enables a subscriber to call back a message sender with the Caller ID number attached to the message.

Caller ID Call Routing

(Available with DPT Integration only.) The VPS automatically sends calls from pre-assigned Caller ID numbers to the specified extension, mailbox (including System Group Distribution List) or Custom Service.

Caller Name Announcement (System/Personal)

(Available with DPT Integration only.) The VPS announces prerecorded Caller ID callers' names when: (1) extension users listen to messages from pre-assigned numbers left in the users' mailboxes, (2) the VPS transfers calls from pre-assigned numbers to the users (Caller ID Screening), and (3) the VPS pages the users by intercom (Intercom Paging).

If the same Caller ID number is programmed for both system and personal caller name announcements, the VPS will use the personal caller name.

Company Greeting

Up to 32 Company Greetings can be recorded to greet callers. One (or System Greeting or none) can be selected for each Day, Night, Lunch, Break, and Holiday service on a port basis and trunk (CO line) basis.

Company Name

This is played by the VPS to the intended receiver of an External Delivery Message when he is unable to enter correctly the password (if required). This helps him to realize where the call came from.

Covering Extension

This can be a destination for Incomplete Call Handling Service. This can also be accessed by pressing [0] while a Personal Greeting is being played, or while a caller is leaving a message.

Custom Service Setting

Allows one-touch access to extensions, other custom service menus, fax machine, mailboxes, etc. A greeting can be recorded for each of the 100 menus to give verbal directions to the non-subscribers.

Default Setting

A parameter defined for the system at the factory which can be changed through system programming by the System Administrator or the System Manager.

Delayed Ringing

There are 2 kinds of delayed ringing applications:

- (1) The VPS is used as the no-answer destination for the Intercept Routing feature of your PBX.
- (2) DIL 1:N (CO line to several extensions) terminates on telephones and VPS ports. To give the telephone users a chance to answer calls, the VPS lines should be programmed for delayed ringing. Otherwise, the VPS will answer the calls immediately.

Delete Message Confirmation

The VPS requests confirmation from the mailbox owner before erasing a message left in the mailbox.

Delivery Time

The time specified by the subscriber for the VPS to deliver a prerecorded message. You can specify delivery time in External Delivery Message or when delivering a message to other subscribers (Subscriber's Guide Section 3.1)

Department Dialing

A speed-dialing feature that permits an outside caller to dial a single digit (1-9) to reach a specific extension.

DID Call Routing

(Available with DPT Integration only on the KX-TD816 [P311Q or higher], KX-TD1232 [P211Q or higher], and the KX-TD500 [V4M or higher].) The VPS automatically sends calls from pre-assigned DID numbers to the specified extension, mailbox (including System Group Distribution List) or Custom Service.

Direct Mailbox Access

(Available with DPT Integration only.) A subscriber can enter his mailbox directly when he calls the VPS from his extension. He does not have to enter any special codes except for his password, if one is established.

DPT Integration

Digital integration between the VPS and the KX-TD500, the KX-TD816, the KX-TD1232, the KX-TA1232, the KX-TD308, or the KX-TDA/KX-TAW series. Requires upgraded software in the PBX.

Depending on the model and/or the software version of the connected PBX, you may not be able to utilize some of the features available only with DPT Integration. For more information, call National Parts Center at 1-800-833-9626.

DTMF

(Dual Tone Multi Frequency) Commonly referred to as touchtone.

Envelope Information Position

Specifies the position of Envelope Information—the name of the person who recorded/transferred a message, or Caller ID Number information.

- (1) Before: The VPS announces Envelope Information before playing the recorded/transferred message.
- (2) After: The VPS announces Envelope Information after playing the recorded message.
- (3) None: The VPS does not announce Envelope Information.

External Call Forwarding

(Available on the KX-TD500, the KX-TD816, the KX-TD1232, the KX-TA1232, the KX-TD308, and the KX-TDA/KX-TAW series.) Forwards calls to an extension that has call forwarding activated to an outside phone.

External Delivery Message

A message intended for automatic delivery to outside parties and/or extensions. The message can be delivered immediately or at a specified time.

External Message Delivery List

Allows the subscriber to create 2 lists to deliver messages to outside parties. Each list can have 8 destinations.

External Message Delivery Redial

Allows the System Administrator to instruct the VPS when making external message deliveries how many attempts to make when the line is busy or when there is no answer.

Fast Forward

Puts the user 4 s ahead in the current message.

Follow-On ID

See Called Party ID.

General Delivery Mailbox

When the caller does not dial anything (either because he does not want to or he is using a rotary telephone), the VPS sends him to the General Delivery Mailbox. Periodically (daily is best), the Message Manager should transfer the contents of the General Delivery Mailbox to the appropriate destinations.

Hash Sign

Same as Pound Sign.

HELP

One of the utility commands that is used to list all utility commands with a brief description of each.

Immediate Reply

Allows the message receiver to reply to a message without specifying the extension number or the mailbox number of the sender.

Inband Signaling

The Follow-On ID (or Called Party ID) that integrates the VPS and the PBX. Uses intercom paths to light message wait light. Does not give "high end" features such as: Intercom Paging, Direct Mailbox Access, Live Call Screening, etc.

Incomplete Call Handling Service

Calls are considered incomplete when there is no answer or if the line is busy.

There are 6 options for the Incomplete Call Handling Service:

- (1) to record a message from the caller,
- (2) transfer the caller to a covering extension,
- (3) page the mailbox owner via the PBX,
- (4) notify the mailbox owner via beeper,
- (5) transfer the caller to the operator, or
- (6) let the caller try another extension.

Integration

Required between the VPS and the PBX. See Inband Signaling and DPT Integration.

Intercept Routing No Answer

Transfers an unanswered call to another extension or to the VPS.
(This is a PBX feature.)

Intercom Paging

(Available with DPT Integration only.) Although Intercom Paging is generally paging through telephones ("internal paging"), paging through external speakers ("external paging") is also supported. Intercom Paging allows up to 16 different paging groups. An outside party can reach a subscriber who is away from his telephone using one of the paging groups that is assigned for the subscriber. (A paging group can be either internal or external.) For a Caller ID caller, if his name has been recorded for the Caller Name Announcement feature, the name will be announced at the end of the page.

Interview Service

A special type of subscriber mailbox that enables the subscriber to record up to 10 questions. After the answers are recorded, the Message Waiting Lamp turns on at the subscriber's telephone. (Good for claims departments, order desks, job applications, etc.)

Keypad

All touchtone keys on the telephone.

LCD

Liquid crystal display

Live Call Screening

(Available with DPT Integration only.) The proprietary telephone works like an answering machine. The subscriber can hear the caller through the speakerphone or the handset while the message is being recorded.

LOAD

One of the utility commands that is used to load new or saved data to the VPS from a personal computer.

Logical Extension (All Calls Transfer to Mailbox)

An extension that always receives calls directly into its mailbox. This feature is used by subscribers who are often unavailable or who do not have a telephone.

Mailbox Capacity (messages)

The number of messages that can be recorded in a subscriber's mailbox: should be set between 5 and 100 messages by the System Administrator or the System Manager.

Mailbox Capacity (recording time)

The total length of time for messages in a subscriber's mailbox: should be set between 5 and 100 min or unlimited length by the System Administrator or the System Manager.

Mailbox Extension

Normally the same number as the telephone extension number.

Mailbox Management

Allows a subscriber to alter the setting for personal mailboxes.

Menu

A list of choices from which the user can select by using the telephone keypad or the keys from a personal computer.

Message Manager

(Mailbox 98, 998, 9998, or 99998) The person who takes care of the General Delivery Mailbox and records: the Company Greetings, Company Name, Department Dialing Menu, Custom Service Menus, Voice Labels, User Prompts (User 1/User 2), Multilingual Selection Menu, and System Caller Names.

Message Retention Time

New Message Retention Time—the length of time the VPS will store a new (unplayed) message before deleting the message.

Saved Message Retention Time—the length of time the VPS will store an old (played) message before deleting the message.

Message Retrieval Order

The order in which the subscriber retrieves messages: Last In First Out (LIFO) or First In First Out (FIFO).

Message Transfer

Allows a subscriber to reroute a message to another mailbox unless the message was marked "private". Additional comments can be added to this message.

Message Waiting Lamp

Light on proprietary telephones that lights when there are messages in the mailbox.

Message Waiting Notification

The VPS can notify subscribers and the Message Manager when they have received messages (if authorized by the System Administrator or the System Manager). There are 3 notification methods: (1) by the Message Waiting Lamp, (2) by a telephone, or (3) by a beeper.

Multilingual Selection Menu

The Message Manager is responsible for recording this menu. Allows callers to choose the language they want (System, User 1 or User 2 prompts) when they call the VPS.

Non-Subscriber

A caller to the VPS who does not own a mailbox.

Notification Method

(See Message Waiting Notification.)

One-Touch Two-Way Transfer (One-Touch TWT)

(Available with DPT Integration only on the KX-TDA/KX-TAW series.) Allows a subscriber to record a conversation into another person's mailbox with one touch.

Operator

Up to three destinations can be assigned as operators. This is the extension that receives calls when the calling party is on a rotary phone or dials [0].

Owner's Name

After a subscriber records his name, the VPS announces his name during transfers, Intercom Paging, and confirmation of Dialing by Name.

Independent of this recording is registration of name by System Administrator. This allows callers to dial parties by name (Dialing by Name) rather than by number. For example, a caller can dial "S-M-I-T" (Smith) rather than Smith's mailbox number, which can be hard to remember.

Password

A combination of numbers selected by the subscriber to protect access to his mailbox. If forgotten, the System Administrator or System Manager can clear it so that the subscriber can select a new password.

Personal Custom Service

Allows a subscriber to set the following Custom Services in his personal greeting (Personal Custom Service):

- (1) Transfer to Mailbox
- (2) Transfer to Extension
- (3) Transfer to Outside
- (4) Custom Service
- (5) VM Service (Voice Mail Service)
- (6) AA Service (Call Transfer Service)

A caller can select a desired service from those above while listening to the personal greeting or recording a message.

Personal Greetings

A subscriber can record messages to greet callers. There are 3 kinds of Personal Greetings:

- (1) No Answer Greeting
- (2) Busy Signal Greeting
- (3) After Hours Greeting

Personal Greeting for Caller ID

(Available with DPT Integration only.) A subscriber can record up to 4 personal greeting messages for calls from pre-assigned Caller ID numbers. Each greeting supports up to 8 Caller ID numbers.

Personal Group Distribution List

A subscriber can maintain up to 4 distribution lists, each containing a maximum of 20 mailboxes. Using this list, he can send the same message to all members of a specific distribution list at once.

Port

The point of connection between the PBX and the VPS.

Pound Sign

The [#] key on the telephone keypad.

Private Message

A message recorded as a private message cannot be forwarded. You can specify privacy when delivering a message to other subscribers (Subscriber's Guide Section 3.1).

Prompt

Prerecorded VPS sentences that guide subscribers and non-subscribers through specific VPS functions. The VPS supports 3 prompts: (1) System prompts (prerecorded at the factory in English), (2) User 1 prompts*, and (3) User 2 prompts*.

Prompts are numbered; the Message Manager can turn off and on the prompts individually.

* freely recorded by the Message Manager

Remote Call Forwarding Set

(Available with DPT Integration only.) A subscriber and the Message Manager can program his extension from a remote location to forward various types of calls to a desired extension or an outside telephone. There are 6 forwarding settings available:

- (1) Forward All Calls
- (2) Forward Busy Calls
- (3) Forward No Answer Calls
- (4) Forward Busy or No Answer Calls
- (5) Forward to a CO Line
- (6) Forward Cancel.

See Remote Call Forward to CO.

Remote Call Forward to CO

(Available with DPT Integration only.) Allows the System Administrator to program Telephone number 1 and Telephone number 2 as the destination to which the callers are forwarded when the Remote Call Forwarding is set to an outside (CO) line. This feature must be enabled in the COS (Class of Service) setting to be utilized. See Remote Call Forwarding Set.

Review

Plays back a message.

Rewind

Replays the last 4 s of a message.

Rotary Telephone

A telephone capable of pulse dial only. Callers using a rotary telephone will be automatically forwarded to the operator or the General Delivery Mailbox.

SAVE

One of the utility commands that is used to save VPS data to a personal computer.

Scanning Messages

Allows the subscriber to listen to only the first 4 s of each message. Another method is to press [2] while listening to a message; this instructs the VPS to skip to the next message.

Service Mode

The System Administrator or the System Manager can change the call handling method programmed for each Time Group 1-8.

Station Programming

Programming via the proprietary telephone.

Subscriber

A person who has an assigned mailbox.

Subscriber Tutorial

When a subscriber accesses his mailbox for the first time, he will be guided to set up these items simply by following Help messages:

- (1) Password
- (2) Owner's Name
- (3) Personal Greetings (No Answer Greeting/Busy Greeting/After Hours Greeting)

System Administration

System programming can be performed via 2 ways: (1) Locally (personal computer connected directly to the RS-232C port of the VPS), or (2) remotely (personal computer connected via the telephone network and the internal modem card [KX-TVS325 only] of the VPS).

Note: Local programming and remote programming are mutually exclusive.

System Administrator

Unlike the Message Manager and the System Manager, who use a telephone to perform their duties, the System Administrator uses a personal computer to program the VPS. The System Administrator's handbook is the Installation Manual.

System External Message Delivery Duration Time

The maximum time allowed for an external message that is to be delivered by the VPS, specified by the System Administrator.

System Group Distribution List

The VPS can maintain up to 20 distribution lists, each containing a maximum of 20 mailboxes. Each list is referenced by a System Group Distribution List number and is assigned via system administration. A recording into a System Group Distribution List number will go into the mailboxes of all group members.

System Manager

(Mailbox 99, 999, 9999, or 99999) The person who can perform very basic and limited system programming using a telephone. He can create/delete mailboxes, clear subscriber passwords when they are forgotten, set Class of Service parameters, set the System Clock, and generate System Reports.

System Report

The System Administrator or System Manager can generate 8 System Reports to monitor the VPS operating status as required.

System Security

By default, the System/Message Managers cannot access the VPS from their telephones until the System Administrator enables the relevant settings and sets a password for access. The System/Message Managers always need to enter this password to access the VPS. The System Administrator can also choose to set a default password for subscribers' mailboxes. If this setting is enabled, a default password is automatically assigned when mailboxes are created.

TIME

One of the utility commands that is used to confirm or set the time and date of the VPS.

Time and Date Stamp Position

Specifies the position of Time and Date Stamp.

- (1) Before: The VPS announces Time and Date Stamp before playing the recorded/transferred message.
- (2) After: The VPS announces Time and Date Stamp after playing the recorded message.
- (3) None: The VPS does not announce Time and Date Stamp.

Time Group

A time frame in which Day, Night, Lunch or Break time period can be programmed. It is possible to assign up to 8 different Time Groups.

Time Synchronization

(Available with DPT Integration only.) When the PBX sets a new date and time or when DPT Integration is established, the data is sent from the PBX to the VPS.

Toll Saver

Is a cost-saving feature that allows a subscriber to check his mailbox from a pre-assigned DID/ Caller ID number without necessarily making the VPS answer the call. Without Toll Saver, the VPS will always answer the call and therefore he will incur toll charges. With Toll Saver, the VPS can let him know that there are no new messages without answering his call.

Two-Way Recording

(Available with DPT Integration only.) Allows a subscriber to record a conversation into his mailbox.

Two-Way Transfer

(Available with DPT Integration only.) Allows a subscriber to record a conversation into another person's mailbox.

Unlimited Message Length

Permits a mailbox owner to record two-way conversations of unlimited length into his or another person's mailbox (Two-Way Recording or Two-Way Transfer). The maximum recording time for other messages will automatically be set to 6 min.

Voice Mail

A general term used for messages recorded over the phone from one person to another.

Voice Prompt

Recorded VPS instructions to callers. These are either system prompts or user prompts.

VPS

Voice Processing System (e.g., Panasonic KX-TVS125, KX-TVS225, and KX-TVS325).

Index

A

- Alternate Extension Group 242
- Auto Configuration 242
- Auto Forwarding 242
- Automated Attendant 243

B

- Broadcasting Messages 243
- Busy Coverage Mode 243

C

- Call Services 243
- Call Transfer No Answer Time 174, 336
- Call Transfer Status 243
- Call Transfer to Outside 247
- Callback Number Entry 244
- Caller ID Call Routing 244
- Caller ID Callback 244, 287
- Caller ID Screening 245
- Caller Name Announcement—Personal 245
- Caller Name Announcement—System 245
- Calling a Beeper 246
- Class of Service (COS) 247
- Company Greeting 193, 247, 376
- Company Name 248
- Company's Telephone No. 339
- Connections—internal modem card 59
- Connections—modular plug 56
- Connections—PBX 55
- Connections—port cards 56
- Covering Extension 248
- Custom Service 248

D

- Data—loading new or saved data to the VPS (LOAD) 212
- Data—saving the system data to the backup device (SAVE) 198, 210
- Daylight Saving Time Assignment 248
- Delete Message Confirmation 248
- Department Dialing 249
- Dialing by Name 249
- DID Call Routing 249
- DIP switch 24, 49, 110, 121, 130, 407
- Direct Mailbox Access 250
- DPT Integration 27, 32, 101, 250

E

- Envelope Information Position 287
- Expansion Capabilities 29
- Extension Group 250
- Extension Numbering Plan 250
- External Message Delivery List 251
- External Message Delivery Service 251
- External Message Delivery Status 252

F

- Fax Management 252

G

- Group Distribution List—Personal 252
- Group Distribution List—System 252

H

- Hardware settings 67, 345
- Hold 253
- Holiday Service 253

I

- Inband Integration 253
- Incomplete Call Handling Service 253
- Initializing the system 202
- Installing port expansion cards: KX-TVS102 or KX-TVS204 51
- Intercom Paging 254
- Internal modem card 29, 59, 233
- Internal modem—initialization 378
- Internal modem—remote programming 233
- Interview Service 255

L

- Live Call Screening 255, 256
- LOAD 212
- Logical Extension (All Calls Transfer to Mailbox) 257

M

- Mailbox 257
- Message Delivery Status 258
- Message Delivery, Internal 257
- Message Management 20, 192
- MESSAGE MANAGER'S GUIDE 387
- Message Reception Mode 258
- Message Scan 258
- Message Transfer 259
- Message Waiting Notification—Device 259
- Message Waiting Notification—Lamp 260
- Multilingual Service 260

N

- No Answer Coverage Mode 261

O

- One-Touch Two-Way Transfer 261
- Operator Service 261

P

- Password Administration 262
- PBX Integration 262
- Personal Custom Service 262
- Personal Greeting for Caller ID 263
- Personal Greetings 263
- Play System Prompt After Personal Greeting 263
- Port Service 264
- Private Message 264

Q

Quick Setup 156, 157, 217

R

Receive Message 264
Remote Call Forwarding Set 265, 403
Remote programming 233
Rotary switch 25, 49, 110, 121, 130
Rotary Telephone Service 265
RS-232C Parameters 345

S

SAVE 198, 210
Service Access Commands 266
Service Mode 266, 374
Special Feature Authorization 267
Specifications—hard disk 44
Specifications—outline 28
Specifications—VPS 238
Subscriber service prompt selection 287
Subscriber Tutorial 267
System Administration 20
SYSTEM ADMINISTRATOR'S GUIDE 273
System Clock 267, 372
System Components 21
System Management 20
SYSTEM MANAGER'S GUIDE 359
System Reports 268
System Security 268

T

Time and Date Stamp Position 287
Time Group 268
Time Service 268
Time Synchronization 268
Toll Saver 269
Troubleshooting 235
Trunk Service (Universal Port) 269
Twenty-four-hour time stamp 330
Two-Way Recording 270
Two-Way Transfer 270

U

Unlimited Message Length 271
Utility Commands 271

V

Voice Mail Service 271
Voice Prompts 271

**Panasonic Consumer Electronics Company
Division of Matsushita Electric Corporation of America**

One Panasonic Way
Secaucus, NJ 07094

**Panasonic Sales Company
Division of Matsushita Electric of Puerto Rico, Inc.**

Ave. 65 de Infantería, Km. 9.5
San Gabriel Industrial Park
Carolina, Puerto Rico 00985

<http://www.panasonic.com/csd>

Copyright:

This manual is copyrighted by Panasonic Communications Co., Ltd. (PCC).
You may print out this manual solely for internal use with this model. Except above, you may not reproduce this manual in any form, in whole or part, without the prior written consent of PCC and its licensee.

© 2004 Panasonic Communications Co., Ltd. All Rights Reserved.