

Panasonic

Cordless Phone

KX-TC187-B

Model No. KX-TC187-W

Pulse-or-tone dialing capability

Operating Instructions



SOUND CHARGER PLUS

25 CHANNEL

KX-TC187-B

PLEASE READ BEFORE USE AND SAVE.

Charge the battery for about 3 hours before initial use.

Getting Started

Basic Operation

Advanced Operation

Useful Information

Before Initial Use

Please read **IMPORTANT SAFETY INSTRUCTIONS** on pages 28-29 before use. Read and understand all instructions.

Thank you for purchasing the Panasonic cordless telephone.

Attach your purchase receipt here.

For your future reference

Serial No. _____

(found on the bottom of the unit)

Date of purchase _____

Name and address of dealer _____

Accessories (To order accessories, call 1-800-332-5368.)

AC Adaptor (p. 8)

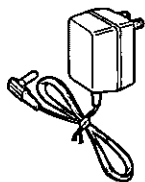

one

Telephone Line Cord (p. 8)

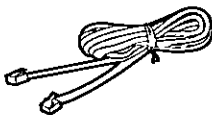

one

Wall Mounting Adaptor (p. 11, 24)

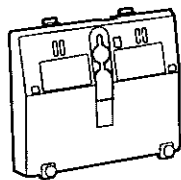

one

For Best Performance

Battery Charge

A rechargeable Ni-Cd battery powers the handset. Charge the battery for about **3 hours** before initial use (p. 9).

The battery is beneath this cover.



Operating Distance/Noise

Calls are transmitted between the base unit and the handset using wireless radio waves. **For maximum distance and noise free operation**, the recommended base unit location is:

Away from electrical appliances such as a TV, radio, or personal computer.

In a **HIGH** and **CENTRAL** location with no obstructions such as walls.

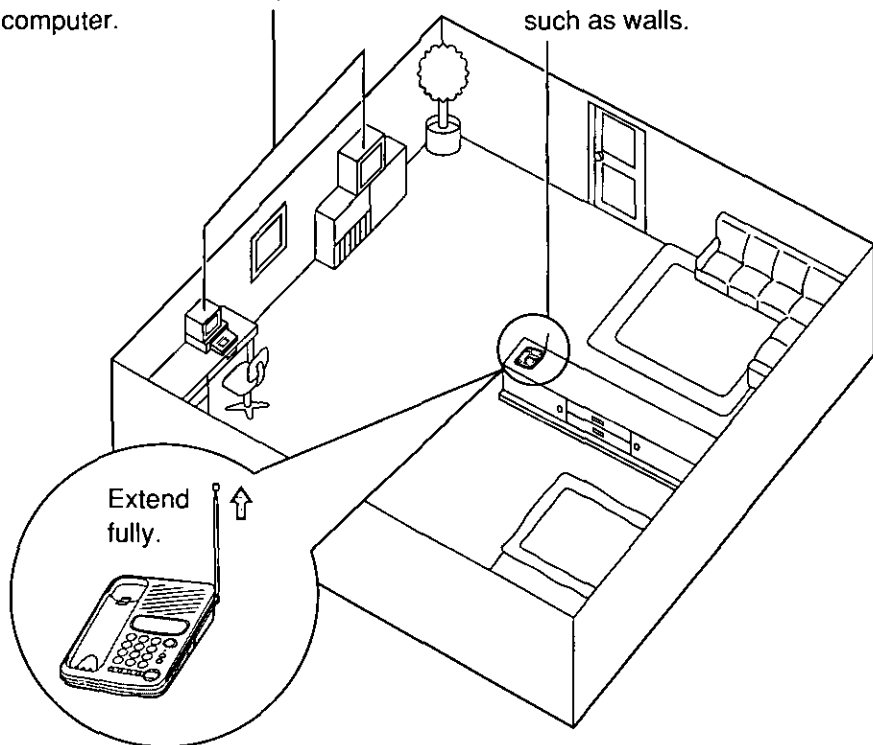

Contents

Getting Started

Location of Controls	6
Settings	8
Connection	8
Battery Charge	9
Selecting the Dialing Mode.....	10
Convenient Desk Usage	11
Adding Another Phone	11

Basic Operation

Making/Answering Calls	12
Making Calls with the Handset	12
Answering Calls with the Handset	13
Making Calls with the Base Unit	14
Answering Calls with the Base Unit	16
Simultaneous Keypad Dialing.....	17
Automatic Dialing	18
Storing Phone Numbers in Memory	18
Dialing a Stored Number	19

Advanced Operation

Intercom 20
 Transferring a Call Using the Intercom 21
Special Features 22
 Automatic Security Code Setting 22
 For Call Waiting Service Users 22
 Temporary Tone Dialing (For Rotary Service Users) 22
 If Your Unit is Connected to a PBX (Analog Only)..... 22

Useful Information

Battery Replacement 23
Wall Mounting 24
Before Requesting Help 26
Important Safety Instructions 28
FCC and Other Information 30

Location of Controls

Handset

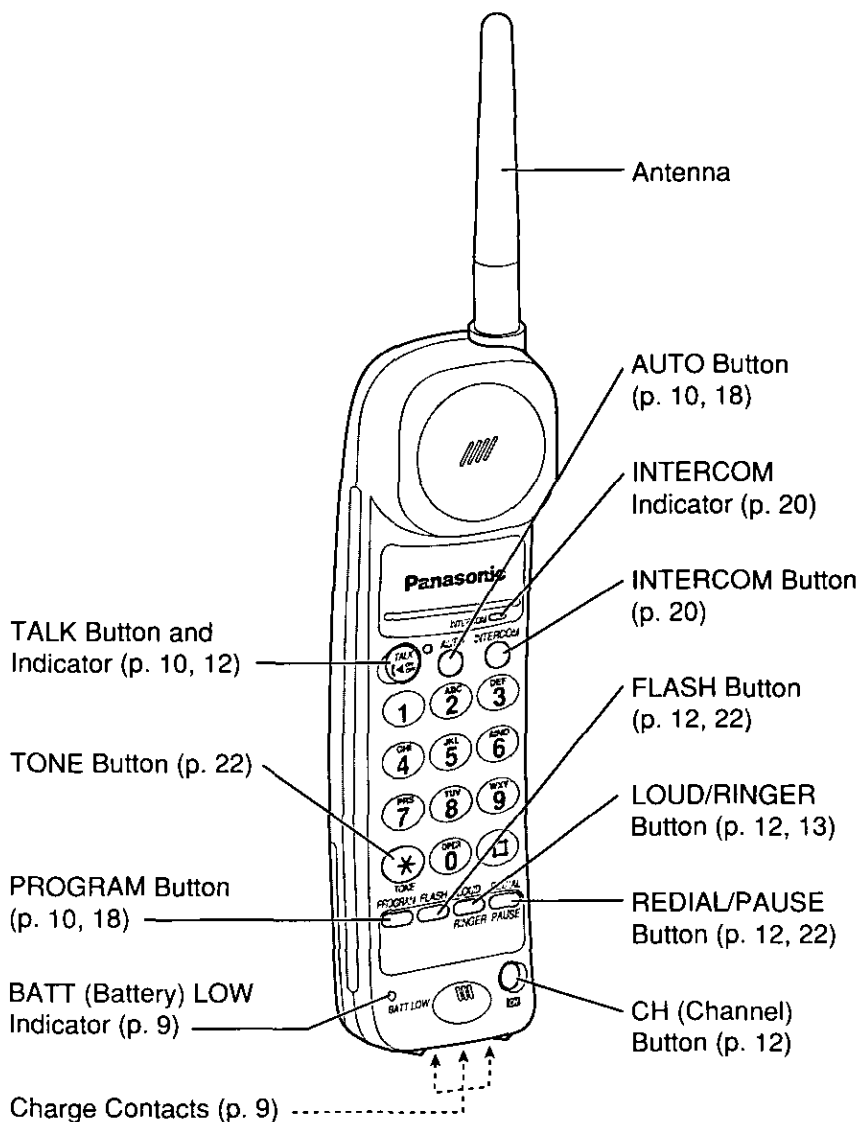

Base unit

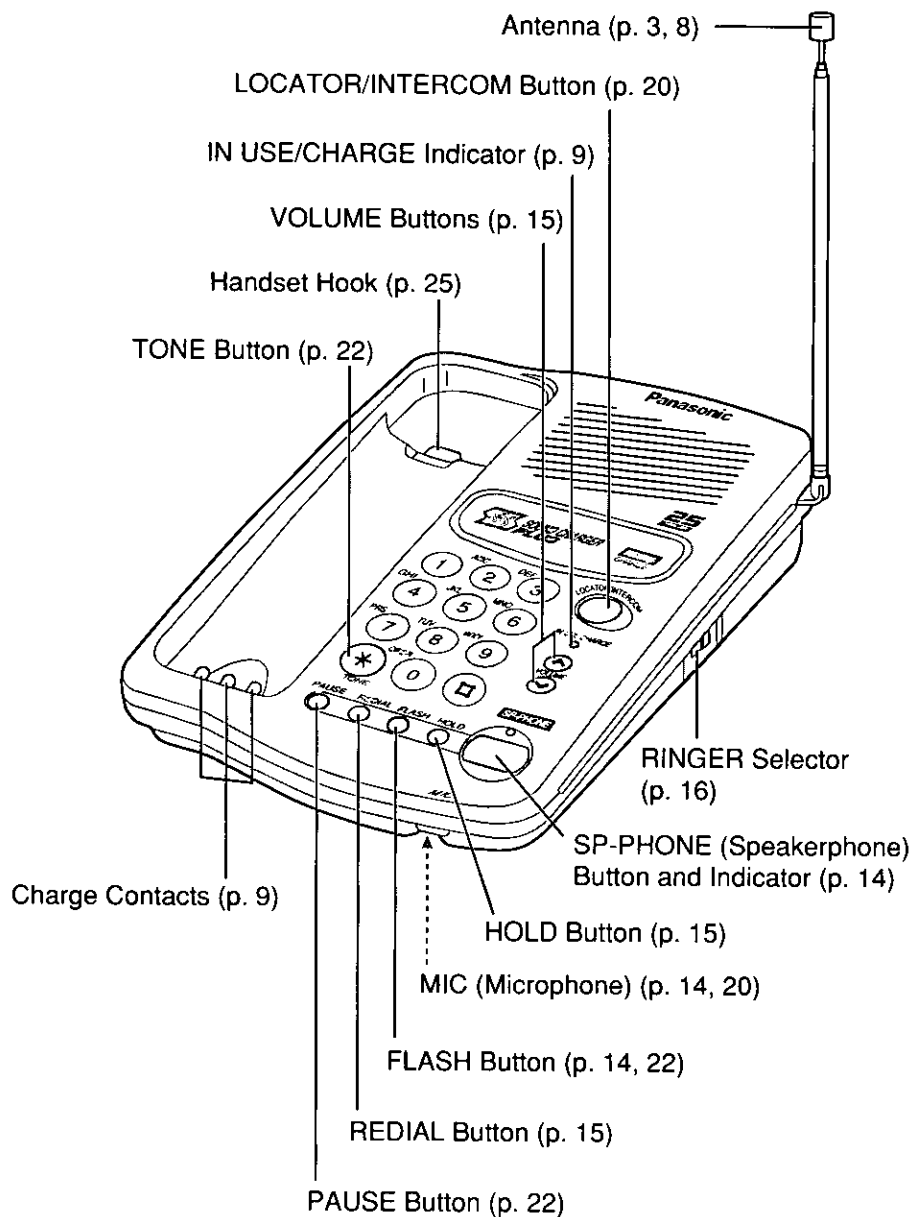

Settings

Connection

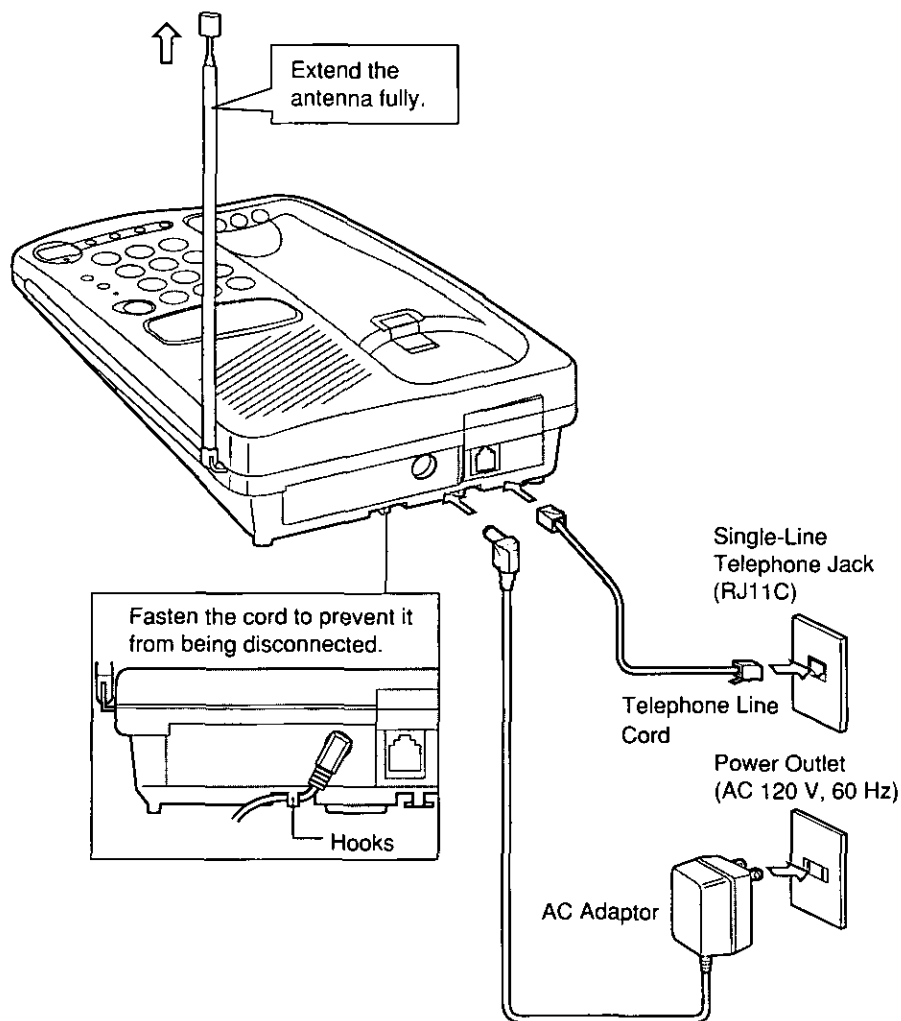

- USE ONLY Panasonic AC ADAPTOR KX-A11.
- The AC adaptor must remain connected at all times. (It may feel warm during use. This is normal.)
- If you connect a standard telephone on the same line, see page 11.



Battery Charge

Place the handset on the base unit for about **3 hours** before initial use.

- The IN USE/CHARGE indicator lights.

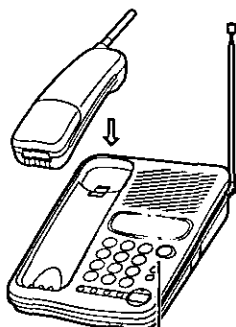

IN USE/CHARGE Indicator

Recharge

When the BATT LOW indicator flashes or the unit beeps intermittently, recharge the battery.

- The BATT LOW indicator will continue to flash for at least 10 minutes once you begin recharging. This time will increase the more you use the handset while recharging.

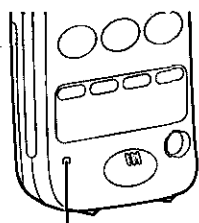

BATT LOW Indicator

Standard battery life

If your Panasonic battery is fully charged;

While in use (TALK)	Up to about 8 hours
While not in use (Stand-By)	Up to about 30 days

- Battery life may vary depending on usage conditions and ambient temperature.
- **Clean the handset and the base unit charge contacts with a soft dry cloth once a month or once a week if the unit is subject to grease, dust or high humidity.** If not, the battery may not charge properly.
- Once the battery is fully charged, you do not have to place the handset on the base unit until the BATT LOW indicator flashes. This will maximize the battery life.
- The battery cannot be overcharged.

Selecting the Dialing Mode

You can program the dialing mode **by using the handset near the base unit**. When your telephone line has touch tone service, set to TONE. If rotary service is used, set to PULSE. The factory preset is TONE.

The TALK and SP-PHONE indicator lights must be off before programming.

- 1 Press **PROGRAM**.
 - The TALK indicator flashes.
- 2 Press **AUTO**.
- 3 To select PULSE, press **☐** twice.
OR
To select TONE, press ***** twice.
- 4 When finished, press **PROGRAM**.
 - A confirmation tone sounds.*

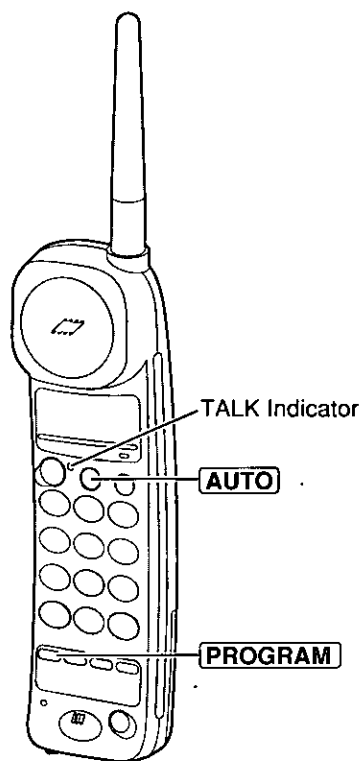

- To cancel programming, press **PROGRAM**, then restart from the beginning.
- If 3 beeps sound during programming, you have pressed a wrong key. Restart from step 1.

*What the confirmation tone means

- 1 beep: The mode is different from a previously selected one.
- 2 beeps: The mode is the same as a previously selected one.

If a power failure occurs, the mode will return to the factory preset (TONE). Reprogram if necessary.

Convenient Desk Usage

The wall mounting adaptor can also be used to raise the unit at an angle.

- ① Insert the tabs of the wall mounting adaptor into the "DESK" openings in the unit.
- ② Push the adaptor in the direction of the arrow.
 - "UP DESK" should face upward.

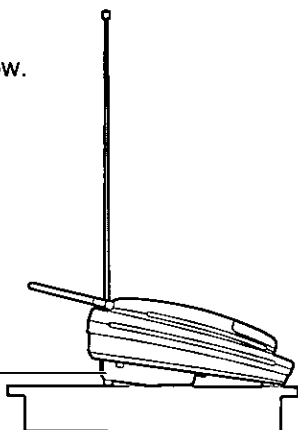
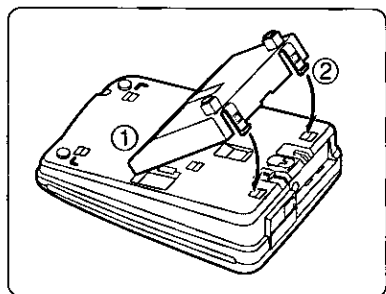

- It is necessary to pull down the handset hook (p. 7).

Adding Another Phone

This unit will not function during a power failure. To connect a standard telephone on the same line, use a Panasonic T-adaptor KX-J66. (To order, call 1-800-332-5368.)

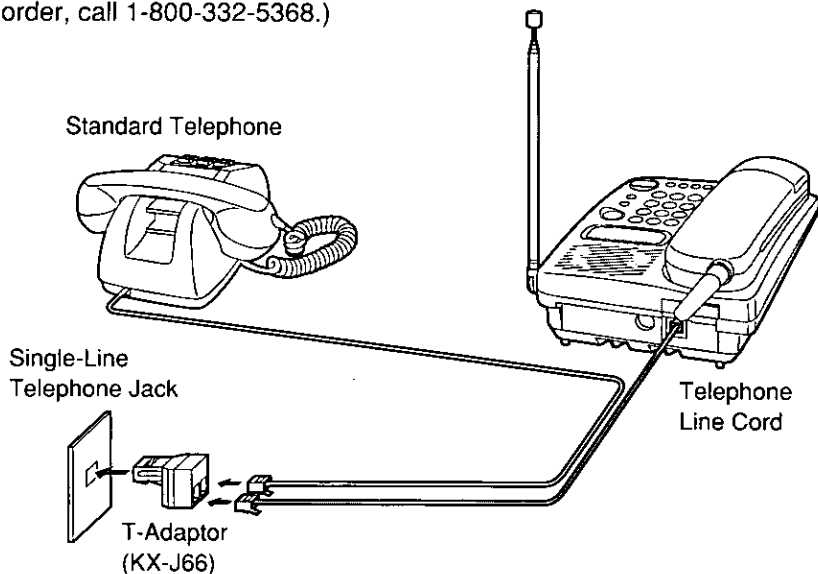

Making/Answering Calls

Making Calls with the Handset

- 1 Press **TALK**.
 - The indicator lights.
- 2 Dial a telephone number.
 - If you misdial, press **FLASH** firmly then dial again.
- 3 To hang up, press **TALK** or place the handset on the base unit.
 - The TALK indicator light goes out.

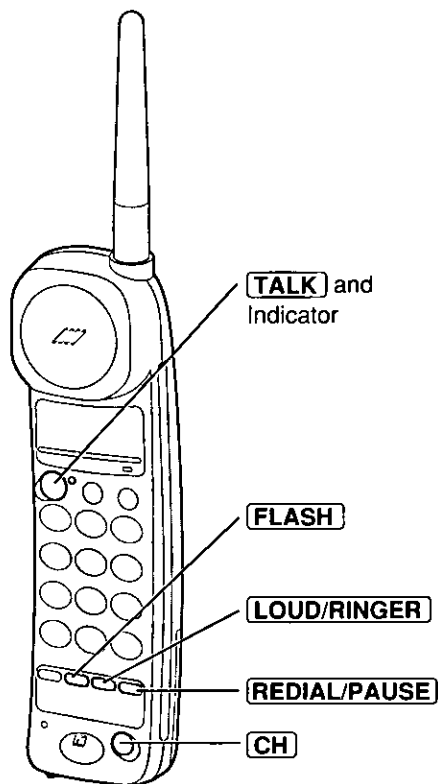

- If an alarm tone sounds in step 1, move toward the base unit or place the handset on the base unit. Then try again.
- To switch to the speakerphone during a call with the handset, see page 17.

To redial the last number

Press **TALK** ⇨ **REDIAL/PAUSE**.

To select the receiver volume LOW, MEDIUM (preset) or HIGH

Press **LOUD/RINGER** while talking.

- Each time you press the button, the volume level will change.
(MEDIUM ⇨ HIGH ⇨ LOW ⇨ MEDIUM ⇨ ...)

If noise interferes with the conversation

Press **CH** to select a clear channel or move closer to the base unit.



Answering Calls with the Handset

If the handset is off the base unit, press **TALK**.

- You can also answer a call by pressing a dialing button 0 to 9, *, or # (**Any key Talk**).

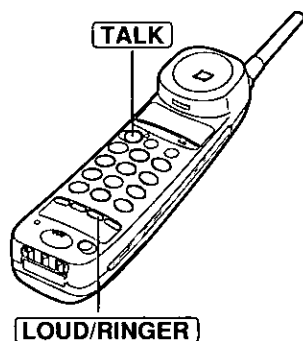

OR

If on the base unit, just lift it up.

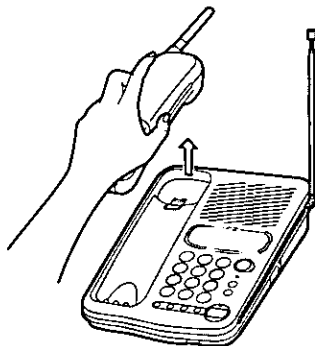

Adjusting the ringer volume

Be sure the TALK indicator light is off.

- To select **HIGH (preset) or LOW**, press **LOUD/RINGER** lightly. (Each time you press the button, the ringer volume will change.)
- To turn the ringer **OFF**, press **LOUD/RINGER** until 2 beeps sound.
- To turn the ringer **ON**, press **LOUD/RINGER** lightly. The ringer sounds at the HIGH level.

Lighted keypad

The dialing buttons will light while dialing and flash when a call is received. The light will go out about 10 seconds after dialing or answering a call.

➔ Making/Answering Calls

Illuminated Talk key

The **TALK** button uses non-radioactive luminescent material which can absorb light energy of sunlight or lamps (incandescent, fluorescent, halogen, etc.) and release this absorbed light for darkened room operation.

- As the absorbed energy in the **TALK** button material decreases, the button brightness will fade naturally.
- Button brightness and duration depends on the amount of room lighting and exposure time.

Making Calls with the Base Unit

- 1 Press **SP-PHONE**.
 - The indicator lights.
- 2 Dial a telephone number.
 - If you misdial, press **FLASH** firmly then dial again.
- 3 When the other party answers, speak into the **MIC** (microphone).
- 4 To hang up, press **SP-PHONE**.
 - The SP-PHONE indicator light goes out.

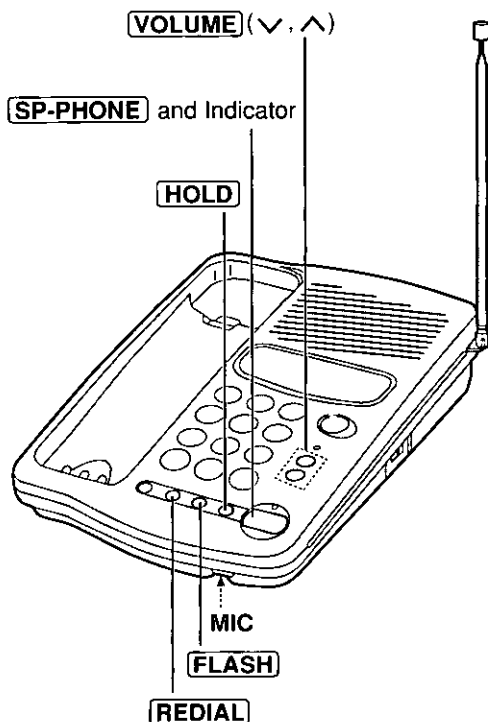

- For best speakerphone performance, use in a quiet room and speak alternately with the caller. If the other party has difficulty hearing you, press ∇ to decrease the speaker volume.
- While using the speakerphone, if the handset is on the base unit, you may switch to the handset by lifting it up.



To adjust the speaker volume (12 levels)

To increase, press \wedge . To decrease, press \vee .

To redial the last number

Press **[SP-PHONE]** ⇨ **[REDIAL]** .

To put a call on hold

Press **[HOLD]** .

- The SP-PHONE indicator flashes.
- If you put a call on hold for 6 minutes, a warning tone will sound.
The call will be disconnected after a total of 10 minutes.

To release the hold

For the base unit, press **[SP-PHONE]** .

For the handset, press **[TALK]** or lift the handset off the base unit.

- If another phone is connected on the same line (p. 11), you can also release the hold by lifting its handset.

➔ Making/Answering Calls

Answering Calls with the Base Unit

- 1 Press **SP-PHONE**.
- 2 Speak into the **MIC**.
- 3 To hang up, press **SP-PHONE**.

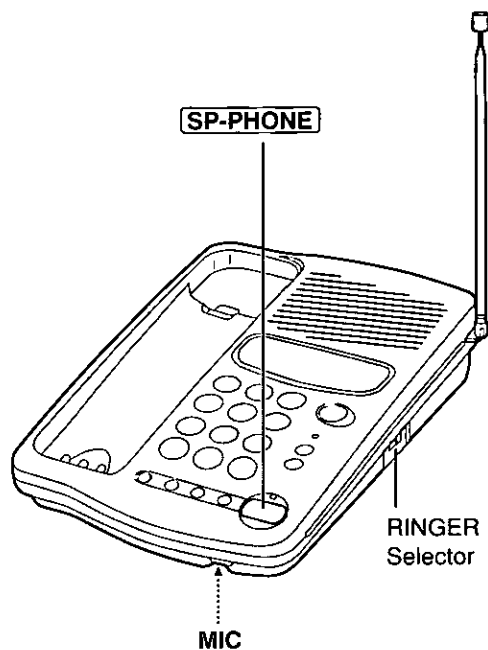

To select the ringer volume

Set the RINGER selector to HIGH, LOW, or OFF.

- When set to OFF, the base unit will not ring.

Simultaneous Keypad Dialing

You can use the base unit like a standard telephone. After pressing **TALK** to make a call with the handset near the base unit, you can also dial using the base unit keypad.

- 1 Handset:**
Press **TALK**.
- 2 Base unit:**
Dial a telephone number while hearing a dial tone with the handset.
 - When the other party answers, talk using the handset.
- 3 Handset:**
To hang up, press **TALK** or place the handset on the base unit.

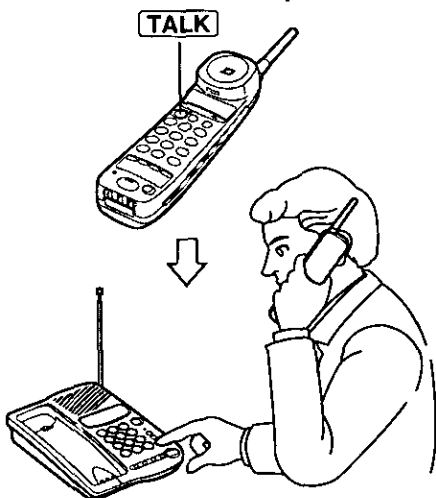

Simultaneous Keypad Dialing is available only after pressing **TALK**.

Useful information

This feature is convenient when you need to enter numbers during a call using the handset (for example, to access an answering service, electronic banking service, etc.). You can enter numbers using the base unit keypad.

- 1. Handset:**
Press **TALK**.
- 2. Handset:**
Dial a telephone number.
 - You may also dial with the base unit keypad.
- 3. Base Unit:**
Enter the required numbers.
- 4. Handset:**
To hang up, press **TALK** or place the handset on the base unit.

Automatic Dialing

Storing Phone Numbers in Memory

You can store up to 10 numbers in the handset. The dialing buttons (0 to 9) function as memory stations. The TALK indicator light must be off before programming.

- 1 Press **PROGRAM**.
 - The TALK indicator flashes.

- 2 Enter a phone number up to 16 digits.
 - If you misdial, press **PROGRAM** to end storing, then restart from step 1.

- 3 Press **AUTO**.

- 4 Press a memory station number (0 to 9).
 - A confirmation tone sounds.*
 - To store other numbers, repeat steps 1 through 4.

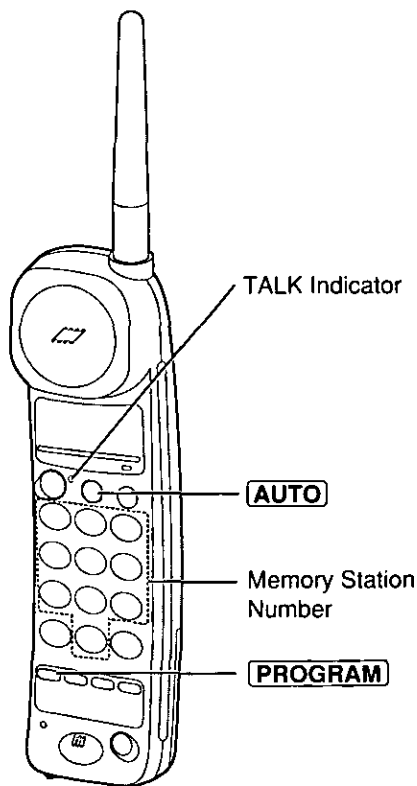

*What the confirmation tone means

1 beep: The new number is stored.

2 beeps: The number is the same as a previously stored one.

To erase a stored number

Press **PROGRAM** ⇒ **AUTO** ⇒ the memory station number (0 to 9) for the phone number to be erased.

Memory sticker

Use the included memory stickers as a name or phone number index for automatic dialing. Attach the sticker to the unit or in a convenient place.

10-STATION AUTOMATIC DIALER	
1	6
2	7
3	8
4	9
5	0
TEL NO.	

Dialing a Stored Number

- 1 Press **TALK**.
- 2 Press **AUTO**.
- 3 Press the memory station number (0 to 9).
 - The stored number is dialed.

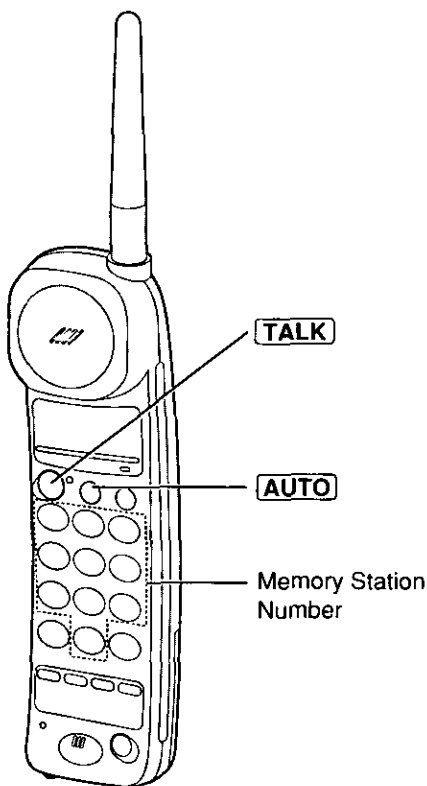

Intercom

A 2-way intercom is available between the handset and the base unit.

Paging the base unit from the handset

- 1 Handset:**
Press **INTERCOM**,
then speak.
 - The indicator lights.
- 2 Base unit:**
When the other party's voice is heard, answer through the **MIC**.
- 3 Handset:**
To end the intercom, press **INTERCOM**.

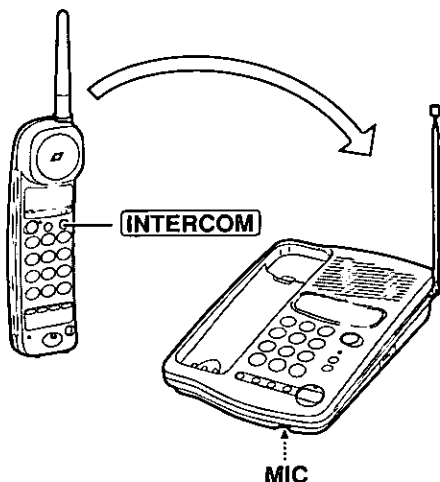

Paging the handset from the base unit (Handset locator)

Using this feature, you can locate the handset if misplaced.

- 1 Base unit:**
Press **LOCATOR/INTERCOM**.
 - The handset beeps for 1 minute.
 - To stop paging, press **LOCATOR/INTERCOM** again.
- 2 Handset:**
Press **INTERCOM** to answer.
- 3 Base unit:**
Speak into the **MIC**.
- 4 Handset:**
To end the intercom, press **INTERCOM**.

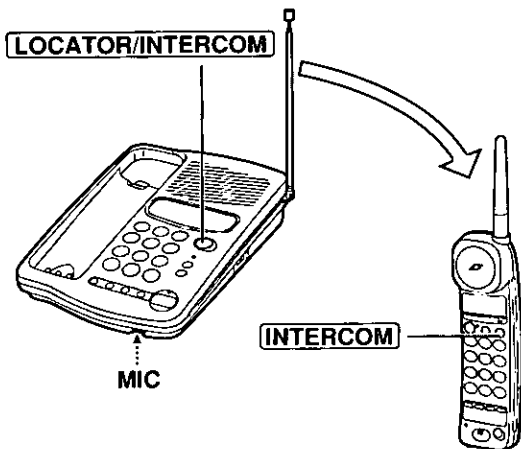

During the intercom:

- Intercom calls can only be ended with the handset.
- If the handset user has difficulty hearing the base unit user, decrease the speaker volume by pressing **✓**.
- If two tones sound, an incoming call has been received. To answer, press **TALK** or **SP-PHONE**. The intercom is ended.

Transferring a Call Using the Intercom

The intercom can be used during a call. This feature enables you to transfer the call between the handset and the base unit.

From the handset to the base unit

- 1** Handset:
During a call, press **INTERCOM**.
 - The call is put on hold.
 - If the base unit does not answer, press **TALK**.
- 2** Base unit:
When the paging party's voice is heard, answer through the **MIC**.
- 3** Base unit:
To answer the call, press **SP-PHONE**.
 - The transfer is completed.
 - The handset user can join the conversation by pressing **TALK**.

From the base unit to the handset

- 1** Base unit:
During a call, press **LOCATOR/INTERCOM**.
 - The call is put on hold.
 - If the handset does not answer, press **SP-PHONE**.
- 2** Handset:
Press **INTERCOM** to answer the page.
- 3** Handset:
To answer the call, press **TALK**.
 - The transfer is completed.
 - The base unit user can join the conversation by pressing **SP-PHONE**.

Special Features

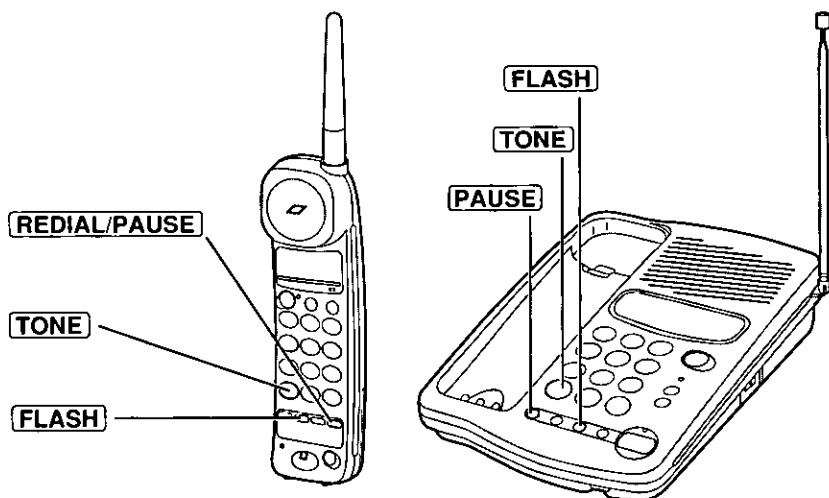

Automatic Security Code Setting

Whenever you place the handset on the base unit, the unit automatically selects one of 65,000 security codes. These codes help to avoid unauthorized use of your telephone line by another cordless telephone.

For Call Waiting Service Users

Press **FLASH** lightly if you hear a call-waiting tone while talking.

- The first call is put on hold and you can answer the second call.
- To return to the first caller, press **FLASH** again.

Temporary Tone Dialing (For Rotary Service Users)

Press **TONE** before entering access numbers which require tone dialing.

- The dialing mode changes to tone. You can enter numbers to access an answering service, electronic banking services, etc. When you hang up, the mode returns to pulse.

If Your Unit is Connected to a PBX (Analog Only)

We recommend you press **PAUSE** or **REDIAL/PAUSE** between the access number for an outside line and the phone number.

- Pressing **PAUSE** or **REDIAL/PAUSE** once creates a 3.5 second pause. This prevents misdialing when you redial or dial a stored number. (**PAUSE** or **REDIAL/PAUSE** counts as one digit.)

Battery Replacement

If the BATT LOW indicator flashes after being fully charged, replace the battery with a new Panasonic P-P301(KX-A36A) battery. (To order, call 1-800-332-5368.) To prevent memory loss, replace within 5 minutes.

- 1 Remove the cover by sliding it while pressing the arrow.

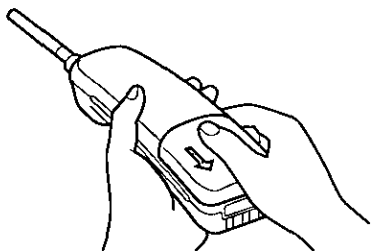

- 2 Replace the battery, then close the cover.

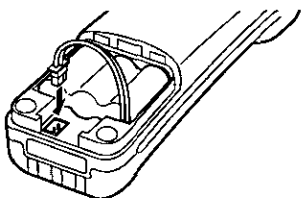

- 3 Be sure to charge the new battery for about 3 hours.

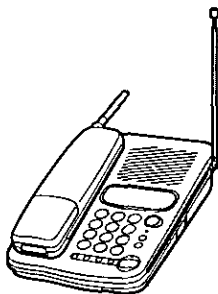

Advanced Operation

Attention:

The product you have purchased is powered by a nickel cadmium battery which is recyclable. At the end of its useful life, under various state and local laws, it is illegal to dispose of this battery into your municipal waste stream. Please call 1-800-8-BATTERY for information on how to recycle this battery.



Wall Mounting

This unit can be mounted on a wall phone plate.

- 1 Connect the AC adaptor.

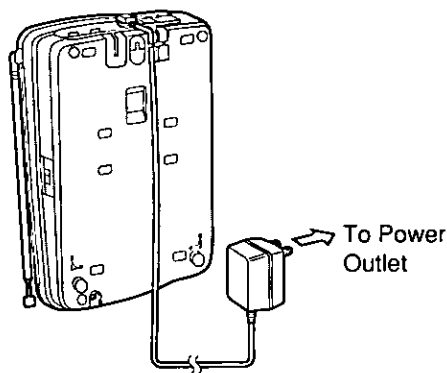

- 2 Tuck the telephone line cord inside the wall mounting adaptor.

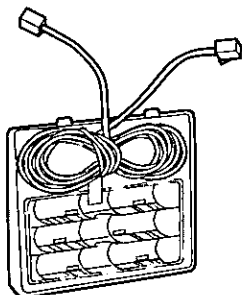

- 3 ① Insert the tabs of the wall mounting adaptor into the "WALL" openings in the unit.
② Push the adaptor in the direction of the arrow.
• "UP WALL" should face upward.

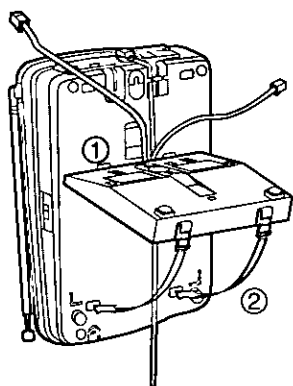

- 4** Connect the telephone line cord. Mount the unit, then slide down.

- Extend the antenna fully.

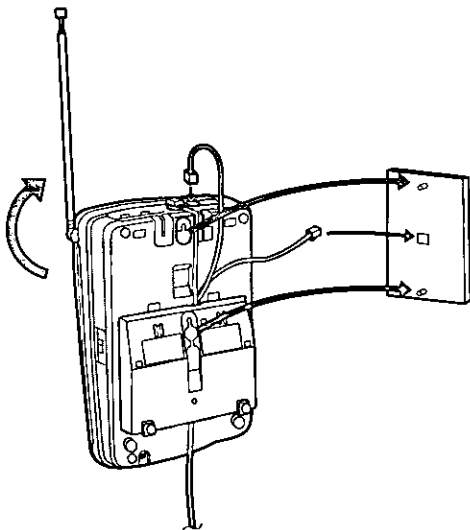

- 5** Pull down the handset hook until it locks **so the tab holds the handset.**

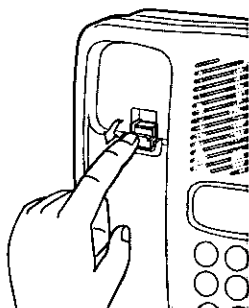

- 6 To charge the battery:**
Place the handset on the handset hook as shown.

- The IN USE/CHARGE indicator lights.

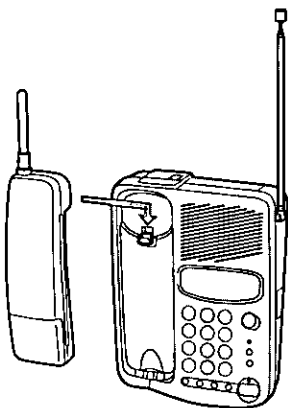

Before Requesting Help

Problem	Remedy
The unit does not work.	<ul style="list-style-type: none">◦ Check the settings (p. 8-10).◦ Charge the battery fully (p. 9).◦ Clean the charge contacts and charge again (p. 9).◦ Install the battery properly (p. 23).◦ Place the handset on the base unit and unplug the AC adaptor to reset. Plug in, then try again.◦ Re-insert the handset battery within 5 minutes to avoid memory loss and place the handset on the base unit. Then try again.
An alarm tone sounds when you press TALK or INTERCOM .	<ul style="list-style-type: none">◦ You are too far from the base unit. Move closer and try again.◦ Place the handset on the base unit and try again.◦ Plug in the AC adaptor.◦ Clean the charge contacts and charge again (p. 9).◦ Extend the base unit antenna fully.
Static, sound cuts in/out, fades. Interference from other electrical units.	<ul style="list-style-type: none">◦ Set the handset and the base unit away from other electrical appliances (p. 3).◦ Move closer to the base unit.◦ Extend the base unit antenna fully.◦ Press CH to select a clearer channel.
The handset does not ring.	<ul style="list-style-type: none">◦ The ringer volume is set to OFF. Press LOUD/RINGER lightly while the TALK indicator light is off (p.13).
The base unit does not ring.	<ul style="list-style-type: none">◦ The RINGER selector is set to OFF. Set to HIGH or LOW.
You cannot store a phone number in memory.	<ul style="list-style-type: none">◦ You cannot store a number while the unit is in the talk, speakerphone or intercom mode.◦ Do not pause for over 30 seconds while storing.

Problem	Remedy
While storing a phone number, the unit starts to ring.	<ul style="list-style-type: none"> • To answer the call, press TALK or SP-PHONE. The program will be canceled. Store the number again.
LOCATOR/INTERCOM does not function.	<ul style="list-style-type: none"> • The handset is too far from the base unit or is engaged in an outside call.
While using the intercom, two tones sound.	<ul style="list-style-type: none"> • A call is being received. To answer, press TALK or SP-PHONE.
REDIAL/PAUSE does not function properly.	<ul style="list-style-type: none"> • It will redial the last dialed number if pressed at the outset of a call (p. 12). If another number has been dialed first, it will operate as a pause button (p. 22).
The BATT LOW indicator flashes or the unit beeps intermittently.	<ul style="list-style-type: none"> • Charge the battery fully (p. 9).
You charged the battery fully, but the BATT LOW indicator flashes.	<ul style="list-style-type: none"> • Clean the charge contacts and charge again (p. 9). • Install a new battery (p. 23).
The IN USE/CHARGE indicator light never goes out while charging.	<ul style="list-style-type: none"> • This is normal.
If you cannot solve your problem.	<ul style="list-style-type: none"> • Call our customer satisfaction center at 1-800-922-0028.

Important Safety Instructions

When using this unit, basic safety precautions should always be followed to reduce the risk of fire, electric shock, or personal injury.

1. Read and understand all instructions.
2. Follow all warnings and instructions marked on this unit.
3. Unplug this unit from AC outlets before cleaning. Do not use liquid or aerosol cleaners. Use a damp cloth for cleaning.
4. Do not use this unit near water, for example, near a bathtub, washbowl, kitchen sink, or the like.
5. Place this unit securely on a stable surface. Serious damage and/or injury may result if the unit falls.
6. Do not cover slots and openings on the unit. They are provided for ventilation and protection against overheating. Never place the unit near radiators, or in a place where proper ventilation is not provided.
7. Use only the power source marked on the unit. If you are not sure of the type of power supplied to your home, consult your dealer or local power company.
8. Do not place objects on the power cord. Install the unit where no one can step or trip on the cord.
9. Do not overload wall outlets and extension cords. This can result in the risk of fire or electric shock.
10. Never push any objects through slots in this unit. This may result in the risk of fire or electric shock. Never spill any liquid on the unit.
11. To reduce the risk of electric shock, do not disassemble this unit. Take the unit to an authorized servicer when service is required. Opening or removing covers may expose you to dangerous voltages or other risks. Incorrect reassembly can cause electric shock when the unit is subsequently used.
12. Unplug this unit from the wall outlet and refer servicing to an authorized servicer when the following conditions occur:
 - A. When the power supply cord or plug is damaged or frayed.
 - B. If liquid has been spilled into the unit.
 - C. If the unit has been exposed to rain or water.
 - D. If the unit does not work normally by following the operating instructions. Adjust only controls covered by the operating instructions. Improper adjustment may require extensive work by an authorized servicer.
 - E. If the unit has been dropped or physically damaged.
 - F. If the unit exhibits a distinct change in performance.
13. During thunderstorms, avoid using telephones except cordless types. There may be a remote risk of an electric shock from lightning.
14. Do not use this unit to report a gas leak, when in the vicinity of the leak.

SAVE THESE INSTRUCTIONS

CAUTION:

To reduce the risk of fire or injury to persons, read and follow these instructions.

1. Use only the battery(ies) specified.
2. Do not dispose of the battery(ies) in a fire. They may explode. Check with local waste management codes for special disposal instructions.
3. Do not open or mutilate the battery(ies). Released electrolyte is corrosive and may cause burns or injury to the eyes or skin. The electrolyte may be toxic if swallowed.
4. Exercise care in handling batteries in order not to short the battery to conductive materials such as rings, bracelets, and keys. The battery and/or conductor may overheat and cause burns.
5. Charge the battery(ies) provided with or identified for use with this product only in accordance with the instructions and limitations specified in this manual.

WARNING:

TO PREVENT FIRE OR SHOCK HAZARD, DO NOT EXPOSE THIS PRODUCT TO RAIN OR ANY TYPE OF MOISTURE.

FCC and Other Information

If requested by the telephone company, inform them as follows:

FCC Registration No.(found on the bottom of the unit)
Ringer Equivalence0.2B
The particular telephone line to which the equipment is connected.

This unit must not be connected to a coin operated line.

If you are on a party line, check with your local telephone company.

Ringer Equivalence No. (REN):

The REN is useful in determining the quantity of devices you may connect to your telephone line and still have all of those devices ring when your telephone number is called. In most, but not all areas, the sum of the REN's of all devices connected to one line should not exceed five (5.0). To be certain of the number of devices you may connect to your line, as determined by the REN, you should contact your local telephone company to determine the maximum REN for your calling area.

In the event terminal equipment causes harm to the telephone network, the telephone company should notify the customer, if possible, that service may be stopped.

However, where prior notice is impractical, the company may temporarily cease service providing that they:

- (a) Promptly notify the customer.
- (b) Give the customer an opportunity to correct the problem with their equipment.
- (c) Inform the customer of the right to bring a complaint to the Federal Communication Commission pursuant to procedures set out in FCC Rules and Regulations Subpart E of Part 68.

The Telephone Company may make changes in its communications facilities, equipment, operations or procedures, where such action is reasonably required in the operation of its business and is not inconsistent with the rules and regulations in FCC Part 68.

If such changes can be reasonably expected to render any customer terminal equipment incompatible with telephone company communications facilities, or require modification or alteration of such terminal equipment, or otherwise materially affect its use or performance, the customer shall be given adequate notice in writing, to allow the customer an opportunity to maintain uninterrupted service.

When programming emergency numbers and/or making test calls to emergency numbers:

1. Remain on the line and briefly explain to the dispatcher the reason for the call before hanging up.
2. Perform such activities in the off-peak hours, such as early morning hours or late evenings.

This device complies with Part 15 of the FCC Rules. Operation is subject to the following two conditions: (1) This device may not cause harmful interference, and (2) this device must accept any interference received, including interference that may cause undesired operation.

Privacy of communications may not be ensured when using this phone.

CAUTION:

Any changes or modifications not expressly approved by the party responsible for compliance could void the user's authority to operate this device.

Note:

This equipment has been tested and found to comply with the limits for a Class B digital device, pursuant to Part 15 of the FCC Rules. These limits are designed to provide reasonable protection against harmful interference in a residential installation. This equipment generates, uses, and can radiate radio frequency energy and, if not installed and used in accordance with the instructions, may cause harmful interference to radio communications. However, there is no guarantee that interference will not occur in a particular installation. If this equipment does cause harmful interference to radio or television reception, which can be determined by turning the equipment off and on, the user is encouraged to try to correct the interference by one or more of the following measures:

- Reorient or relocate the receiving antenna.
- Increase the separation between the equipment and receiver.
- Connect the equipment into an outlet on a circuit different from that to which the receiver is connected.
- Consult the dealer or an experienced radio/TV technician for help.

Some cordless telephones operate at frequencies that may cause interference to nearby TVs and VCRs. To minimize or prevent such interference, the base of the cordless telephone should not be placed near or on top of a TV or VCR. If interference is experienced, move the cordless telephone further away from the TV or VCR. This will often reduce or eliminate interference.

- **Environment** — do not place the unit in room where the temperature is less than 5°C (41°F) or greater than 40°C (104°F). Allow 10 cm (4") clearance around the unit for proper ventilation. Avoid excessive smoke, dust, mechanical vibration, shock, or direct sunlight.
- **Routine care** — wipe the unit with a soft cloth. Do not use benzine, thinner, or any abrasive powder. When you left the unit unused for long time, unplug the AC adaptor from the outlet.
- **If there is any trouble** — disconnect the unit from the telephone line and connect a known working phone. If the known working phone operates properly, have your unit repaired by one of the authorized Panasonic Factory Service Centers. If the known working phone does not operate properly, consult with your telephone company.

For product service

- Panasonic Servicenters are listed in the servicenter directory.
- Call 1-800-545-2672 for the location of an authorized servicenter.

When you ship the product

- Carefully pack your unit, preferably in the original carton.
- Attach a letter, detailing the symptom, to the outside of the carton.

Symptom

- Send the unit to an authorized servicenter, prepaid and adequately insured.
- Do not send your unit to the Panasonic Consumer Electronics Company listed below or to executive or regional sales offices. These locations do not repair consumer products.

- This cordless telephone is designed for use in the United States of America. Sale or use of this product in other countries may violate local laws.
- Ce téléphone sans fil est conçu pour être utilisé aux États-Unis d'Amérique. La vente ou l'emploi de cet appareil dans certains autres pays peut constituer une infraction à la législation locale.
- Este teléfono sin cordón fue elaborado para uso en los Estados Unidos de América. La venta o el empleo de este producto en ciertos países puede constituir violación de la legislación local.
- このコードレス電話機は、日本国外での使用を目的として設計されており、日本国内での使用は法律違反となります。従って、当社では日本国内においては原則として修理などのサービスは致しかねます。

Panasonic Consumer Electronics Company,
Division of Matsushita Electric Corporation of America
One Panasonic Way, Secaucus, New Jersey 07094

Panasonic Sales Company,
Division of Matsushita Electric of Puerto Rico, Inc.
Ave. 65 de Infantería, Km. 9.5, San Gabriel Industrial Park
Carolina, Puerto Rico 00985