

**NEC**

ND-16982

ISSUE IV

**Electra-16/48**

ELECTRONIC KEY TELEPHONE SYSTEM

**INSTALLATION  
SERVICE  
MANUAL**

APRIL, 1983

**NEC Corporation**

# INSTALLATION SERVICE MANUAL

## TABLE OF CONTENTS

<u>SECTION</u>	<u>TITLE</u>	<u>SECTION</u>	<u>TITLE</u>
<b>A</b>	<b>REGULATORY INFORMATION</b>	240	INSTALLATION OF KTUs
<b>1</b>	<b>INTRODUCTION</b>	250	MDF INSTALLATION (CABLING)
<b>100</b>	<b>GENERAL INSTALLATION</b>	260	INSTALLING STATION EQUIPMENT
110	INSTALLATION SITE REQUIREMENTS	270	INSTALLING OPTIONS
120	ELECTRICAL AND GROUNDING REQUIREMENTS	<b>300</b>	<b>PROGRAMMING</b>
130	OTHER CONSIDERATIONS	310	EXPLANATION OF PROGRAMMING
140	SPECIFICATIONS	320	PROGRAMMING OPERATIONS
150	LIST OF EQUIPMENT	330	JOB SPECIFICATION
160	SYSTEM CONFIGURATION	340	PROGRAMMING SHEETS
<b>200</b>	<b>HARDWARE INSTALLATION</b>	<b>400</b>	<b>STATION OPERATION PROCEDURE</b>
210	INSTALLING THE CENTRAL EQUIPMENT	410	KEY TELEPHONE OPERATION
220	INTERCONNECTING KSUs	420	SINGLE LINE TELEPHONE OPERATION
230	CONNECTING AND TESTING POWER SUPPLIES	430	DSS/BLF OPERATION

## SECTION A REGULATORY INFORMATION

### Regulatory Requirements

1. The Federal Communications Commission (FCC) has established Rules which permit the Electra-16/48 Electronic Key Telephone System to be directly connected to the telephone network. A jack is provided by the telephone company. Jacks for this type of customer-provided equipment will not be provided on party lines or coin lines.
2. If the Electra-16/48 System is malfunctioning, it may also be causing harm to the telephone network. The Key Telephone System should be disconnected until the source of the problem can be determined and until repair has been made. If this is not done, the telephone company may temporarily disconnect service.
3. The telephone company may make changes in its technical operations and procedures. If such changes affect the compatibility or use of the Electra-16/48 System, the telephone company is required to give adequate notice of the changes.
4. In compliance with FCC Part 15 rules, the following statement is provided:

**Warning:** "This equipment generates, uses, and can radiate radio frequency energy and if not installed and used in accordance with the instructions manual, may cause interference to radio communications. It has been tested and found to comply with the limits for a Class A computing device pursuant to Subpart J of Part 15 of FCC Rules, which are designed to provide reasonable protection against such interference when operated in a commercial environment. Operation of this equipment in a residential area is likely to cause interference in which case the user at his own expense will be required to take whatever measures may be required to correct the interference."

### Company Notification

Before installing the Electra-16/48 Electronic Key Telephone System to the telephone network, the telephone company must be provided with the following:

- a. Your telephone number
- b. The FCC registration number: AY589N-68384-MF-E
- c. The ringer equivalence number: 2.1 B
- d. The USOC jack required: RJ21X

Item b., c., and d. are also indicated on the System equipment label.

### Service Requirements

In the event of equipment malfunction, all repairs will be performed by NEC or an authorized agent of NEC. It is the responsibility of users requiring service to report the need for service to NEC or to one of their authorized agents.

## SECTION 1 INTRODUCTION

### 1. Manual and Supporting Documents

1.01 This manual provides the information required to install and maintain the Electra-16/48 Electronic Key Telephone System. It covers the areas of: site selection, configuring a system, hardware installation, programming, post-installation testing and maintenance. Technical Bulletins pertinent to this system should be attached to it to provide a complete and current field book.

1.02 The Electra-16/48 Electronic Key Telephone System is also the subject of the following documents:

ND-16981	NEC Electra-16/48 General Description
ND-16983	NEC Circuit Description
ND-16984	NEC Schematic Drawings

1.03 It is recommended that the installer make himself familiar with this document before beginning installation.

## SECTION 100 GENERAL INSTALLATION

### 110 Installation Site Requirements

#### 110.1 Physical Environment of Equipment

The following conditions should be met by the site chosen for mounting the central equipment (Key Service Unit(s)).

1. The KSU(s) should normally be wall-mounted to protect against accident or flooding. Where possible use of a wooden backboard is recommended for this purpose.
2. The KSU(s) should not be located directly beneath pipes due to the possibility of leaks or condensation causing damage.
3. The area in which the KSU(s) is located must be free of: corrosive or inflammable gases, excessive chemical or industrial dusts, and such materials which could cause hazard to personnel or to the proper functioning of the equipment.
4. Heat and humidity must be within the limits set by "Specifications" found in Section 140 of this manual.
5. Although its virtually noiseless operation allows a wide choice of installation sites, care should be taken that the KSU(s) not present a hazard to office traffic. For purposes of economy a central location (to minimize cabling) is often preferable.

### 120 Electrical and Ground Requirements

#### 120.1 AC Power Requirements

1. The system should have a dedicated 117V AC outlet separately fused for 15 AMPS.
2. The AC outlet should be a standard 125V AC three-prong type which provides conduit ground.
3. The AC power must be within the limits set by "Specifications" found in Section 140 of this manual.
4. If the AC outlet is subject to power surges, it is recommended that the best locally available surge protection be installed.
5. If conversion to permanent wiring is required by local codes, then follow instructions as described by tag attached to power supply cord.

#### 120.2 Grounding Requirements

The KSU(s) must be well-grounded. If a good conduit ground is not present at the dedicated AC outlet, the following steps should be taken:

1. Provide a suitable waterpipe ground in accordance with the local operating (telephone) company procedures.
2. If no waterpipe ground is available, a ground rod should be installed in accordance with local operating company procedures.
3. In the case where a ground other than conduit ground is used a grounding terminal is provided on the ES-16-2 as shown below in Figure 120-1.

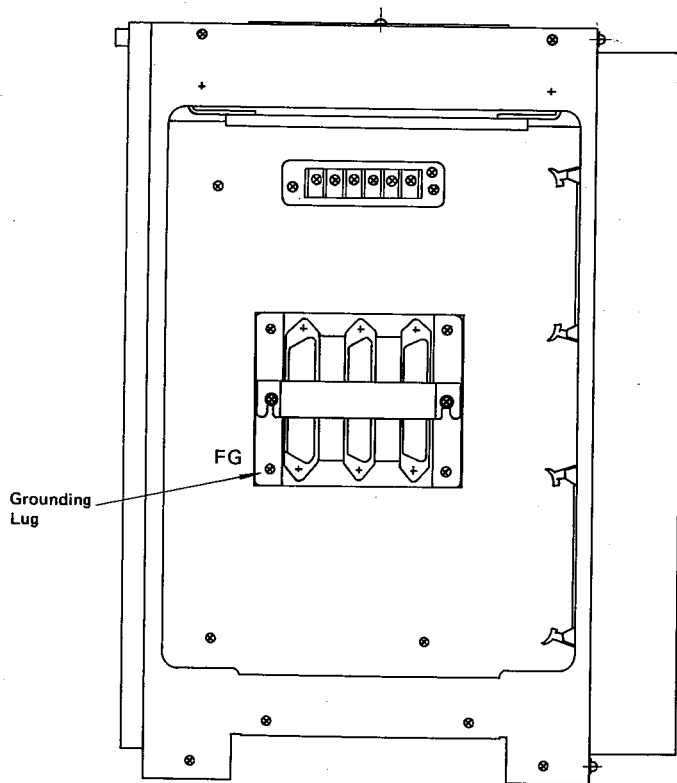

Fig. 120-1 Sideview of ES-16-2

## 130 Other Considerations

### 130.1 Electrical Noise Generators

Certain equipment, such as welding machines, thyristor-driven power supplies, large electrical motors, etc. generate electrical noise. As a stored program machine the Electra-16/48 System is vulnerable to this noise. When this type of machine is present at an installation, the following precautionary steps are urged:

1. Locate KSU(s), telephone sets, and cabling away from these machines.
2. If cables must pass near these machines, use shielded cable with the shield grounded.
3. Ensure all machines of this type are well-grounded to a separate ground to minimize noise interference.

### 130.2 Pre-installation Site Survey

Since a pre-installation survey is generally required to plan for application and installation, a check of the matters covered so far in this section at this time will prevent later problems.

### 130.3 Additional Equipment

In addition to electronic station equipment and the KSU(s) and their contents, other equipment is required. This includes cables, modular connecting jacks, quick-connect blocks (or similar apparatus), etc. This additional equipment must be locally supplied.

## 140 Specifications

### 140.1 System Capacity

1. Electra 16/48 system capacity is as follows:

CO/PBX Lines	16 max.
Intercom Paths	5 max.
Station Sets	48 max.
DSS/BLF Consoles	2 max. (1) (0) See Note
BLF Consoles	4 max. (5) (6)

2. The central equipment of the Electra 16/48 system is composed of up to 3 stacked Key Service Units:

1. Basic Cabinet	ES-16-2 KSU
2. Second Cabinet	ES-48/32-1 KSU
3. Third Cabinet	ES-48/32-1 KSU

System limits are affected by the number of KSUs.

- 1) Basic system (with ES-16-2 KSU only):

CO/PBX Lines	8 max.
Intercom Paths	5 max.
Station Sets	16 max.
DSS/BLF Consoles	2 max. (1) (0) See Note
BLF Console	1 max. (2) (3)

- 2) Two KSU system (with ES-16-2 and ES-48/32-1):

CO/PBX Lines	12 max.
Intercom Paths	5 max.
Station Sets	32 max.
DSS/BLF Consoles	2 max. (1) (0) See Note
BLF Console	4 max. (5) (6)

- 3) Three KSU system (with ES-16-2 and two ES-48/32-1):

CO/PBX Lines	16 max.
Intercom Paths	5 max.
Station Sets	48 max.
DSS/BLF Consoles	2 max. (1) (0) See Note
BLF Consoles	4 max. (5) (6)

**Note:** DSS/BLF consoles can be replaced with BLF consoles as shown.

## 140.2 Cabling Requirements

1. Cabling required for Key Telephone Sets, DSS/BLF Consoles, BLF Consoles, Single Line Sets is as follows:

1) Required Cable

- Key Telephone Set: Twisted 2-pair cable
- Single Line Set: Twisted 1-pair cable
- DSS/BLF Console: Twisted 1-pair cable
- BLF Console: Twisted 1-pair cable

2) Maximum Loop Resistance and Cable Length at 24AWG

- Key Telephone Set: 55 ohms, 1,000 ft. (300m)
- Single Line Set: 200 ohms, 3,600 ft. (1,080m)
- DSS/BLF Console: 55 ohms, 1,000 ft. (300m)
- BLF Console: 55 ohms, 1,000 ft. (300m)

3) Maximum Cable Length at 22AWG

- Key Telephone Set: 1,580 ft. (Limited by delay Time of Data)
- Single Line Set: 5,750 ft. (Limited by Resistance)
- DSS/BLF Console: 1,580 ft. (Limited by delay Time of Data)
- BLF Console: 1,580 ft. (Limited by delay Time of Data)

2. DSS/BLF and BLF Consoles require a local power supply (provided with each unit) which plugs into a 117V AC outlet. The power cable provided with these units is 6 feet in length.

## 140.3 Power Requirements

1. AC Input

- 117V AC  $\pm$  10%, 50 or 60Hz  $\pm$  10%, single phase
- Max. current draw per PSU
  - PS-16-1 5.0A
  - PS-48/32-1 5.0A each
- Dedicated outlet separately fused at 15A max.

## 2. Power Supply Outputs

PSU	PS-16-1	PS-48/32-1
DC Voltage	Max. Current	Max. Current
5 $\pm$ 0.25V	5.0A	2.0A
12 $\pm$ 0.5V	2.0A	1.0A
24 $\pm$ 0.5V	2.0A	2.0A
41 $\pm$ 1.0V	3.0A	3.0A

3. RSG-N Unit

Output Voltage: 67 ~ 100V RMS

Output Frequency: 16 ~ 25 Hz

Output Power: 2.0VA

4. DSS/BLF and BLF Power Supply

Output Voltage: 6V DC

Max. Output Current: 1.5 A

5. Fuse Replacement

When a fuse is blown, replace the fuse as shown in Table 140.1, Table 140-2, and Table 140.3.

**Table 140-1 Fuse Specifications for PS-16-1 (Note 1)**

Designation	Specification	Description
F1	125V., 6A	AC Input
F2	125V., 1.5A	Rectifier and Capacitor Network Short
F3	125V., 4A	+41V DC For Keyset
F4	125V., 2.5A	+24V DC For Talk Battery and Relay Operation
F5	125V., 2.5A	+12V DC For Logic Circuits
F6	125V., 6A	+5V DC For Logic Circuits

**Table 140-2 Fuse Specifications for PS-48/32-1 (Note 1)**

Designation	Specification	Description
F1	125V., 6A	AC Input
F2	125V., 1A	Rectifier and Capacitor Network Short
F3	125V., 4A	+41V DC For Keyset
F4	125V., 2.5A	+24V DC For Talk Battery and Relay Operation
F5	125V., 1.5A	+12V DC For Logic Circuits
F6	125V., 2.5A	+5V DC For Logic Circuits

**Table 140-3 Fuse Specifications for RSG-N and KSI-N (Note 2)**

Designation	Specification	Description
F1	125V., 1.0A	RSG-N
F1-F4	125V., 0.5A	KSI-N

**Note 1:** *F1 thru F6 are 1/4" x 1-1/4" size normal blown glass tube or ceramic fuses.*

**Note 2:** *RSG-N F1 and KSI-N F1 – F4 are 13/64" x 45/64" (5mm x 20mm) size normal blown glass tube fuse.*



#### 140.4 Surge Protection

If an installation is subject to AC power surges it is recommended that the most effective locally-available form of surge protection be supplied.

CO Lines are protected by the local operating (telephone) company. It is recommended that the most effective locally available form of protection be installed on CO/PBX lines by the local operating (telephone) company.

**Note:** *This is NOT a recommendation that more than one set of protectors be installed on CO lines at installation premises. Improper installation of additional protection can be a serious safety hazard.*

#### 140.5 Environmental Conditions

##### 1. Temperature:

Operating +32°F ~ 104°F (0°C ~ 40°C)

##### 2. Humidity:

Operating 10 ~ 90 percent

#### 140.6 Dimensions and Weights

Description	Dimension (mm)	Net Weight (kg)
ES-16-2 KSU	484(W) × 300(D) × 400(H) (19.0 × 11.8 × 15.7 inch)	15.5
ES-48/32-1 KSU	484(W) × 300(D) × 250(H) (19.0 × 11.8 × 9.8 inch)	9.3
PS-16-1 PSU	254(W) × 300(D) × 400(H) (10.0 × 11.8 × 15.7 inch)	10.8
PS-48/32-1 PSU	254(W) × 300(D) × 250(H) (10.0 × 11.8 × 9.8 inch)	8.5
RSG-N UNIT	160(W) × 250(D) × 110(H) (6.3 × 9.8 × 4.3 inch)	4.3
ET-16-1 TEL & ET-8-2 TEL	240(W) × 245(D) × 90(H) (9.4 × 9.6 × 3.5 inch)	1.6
ED-48-1 DSS/BLF		2.2
EB-48-1 BLF	124(W) × 245(D) × 88(H) (4.9 × 9.6 × 3.5 inch)	1.0

#### 140.7 Network and Control

##### 1. Control

- Control: Stored program micro-processor control
- Central processor: 8085A
- Microprocessors in station interface cards and keyset:  $\mu$ COM43N (One-chip 4 bit micro-computer)
- Clock (KSU-keyset): 30 kHz
- Transmission data: 32 bits (from KSU to keyset)
- Transmission data: 16 bits (from keyset to KSU)
- Scanning time for each keyset: Every 60 msec.
- Number of cable pairs from KSU to each station: 2 pair wire for keyset  
1 pair wire for single line set
- For keyset, one pair: Voice and signaling  
one pair: Data sending and receiving
- For single line set, one pair: Voice and signaling
- KSU to each DSS/BLF or BLF: One pair wire for data sending and receiving

##### 1. Network

- Cross point switch: C-MOS switch
- Keyset network: Equivalent to 500 type standard network
- Transmitter and Receiver: Equivalent to 500 type standard telephone set used
- Single line set: Standard 2500 type telephone set

## 140.8 Indications

### 1. Visual

Lamp indications of a Keyset are as follows:

- Idle condition: Not lit
- Busy CO/PBX and intercom: Steady light
- Incoming CO/PBX and intercom call: Flashing light at 60IPM
- Call hold CO/PBX: Winking light at 120IPM
- I-hold indication (CO/PBX) ICM hold: Intermittent wink light
- Automatic hold recall, attendant recall, attendant camp-on transfer: Rapidly winking light at 480IPM

### 2. Audible Indications

#### 1) CO/PBX call

- Incoming call on CO/PBX
  - Keyset: Modulated tone (500/600Hz modulated by 12.5Hz, 1 sec. ON/1 sec. OFF)
  - Single line set: Ringer (20Hz 2 sec. ON/4 sec. OFF)
- Automatic hold recall and Attendant recall: The same as call waiting tone (1200Hz tone intermittent at 60IPM)

#### 2) Intercom Call

- Calling signal for called station
  - Keyset: Voice signaling after tone burst (by depressing DSS button or dialing station number)  
Tone signaling by dialing from single line set or by dialing 1 from keyset after dialing station number.  
500Hz, 0.5 sec. ON/0.5 sec. OFF/0.5 sec. ON/2.5 sec. OFF.

- Single line set: Ringer  
20Hz 0.5 sec. ON/0.5 sec. OFF/0.5 sec. ON/2.5 sec. OFF
- Dial tone: 500 Hz continuous tone
- Ringback tone: 500Hz intermittent at 0.5 sec. ON/0.5 sec. OFF/0.5 sec. ON/2.5 sec. OFF
- Busy tone/Error tone: 500Hz intermittent tone at 60IPM
- Call waiting tone: 1200Hz tone intermittent at 60IPM
- Override tone:
  - Keyset: Modulated tone, 0.5 sec.
  - Single line set: 2400Hz, 0.5 sec.

## 140.9 Dialing Specifications

### 1. Dial Pulse Address Signaling

- a) Pulse rate: 10pps
- b) Percent break:  $61 \pm 3$  percent
- c) Interdigital interval: 800 msec.

### 2. DTMF Address Signaling

- a) Frequencies: Two sinusoidal signals, one from a high group of three frequencies and one from a low group of four frequencies

Nominal High Group frequencies (Hz)

	1209	1336	1477
697	1	2	3
Nominal	770	4	5
Low Group	852	7	8
Frequencies (Hz)	941	*	0
			#

- b) Frequency deviation: Within  $\pm 1.5$  percent

- c) Signal level
    - Nominal level per frequency: -6 to -4dBm
    - Minimum level per frequency:
      - Low group: -10dBm
      - High group: -8 dBm
    - Maximum level per frequency pair: +2 dBm
  - d) Rise time: Within 5 msec
  - e) Duration of dual frequency signal: 60 msec. min
  - f) Interdigital time: 100 msec. min.
3. Dialing Memories
- (a) Last CO/PBX Number Redial: 16 digits max.
  - (b) Speed Dialing-Station: 10 numbers (16 digits) per station
  - (c) Speed Dialing-System: 10 numbers (16 digits)

#### 140.10 External Equipment Interfacing

1. EP-N Output
  - Output power: 3 watts
  - Required speaker impedance: 600 ohms
2. Output to External Amplifier for External Paging
  - Output power: -15 dBm
  - Output impedance: 600 ohms
3. BGM Input to EP-N
  - Input level: 3 watt (nominal)
  - Required output impedance of amplifier: 600 ohms
4. MOH Input to ES-16-( ) KSU
  - Input level: 1m watt (nominal)/600 ohms
  - Required output impedance of signal source: 600 ohms
5. Output to CO/PBX Common Audible External Amplifier
  - Output power: -15 dB (nominal)
  - Required input impedance of amplifier: More than 1k ohms
6. Output from SMDS-N KTU
  - RS-232C Interface

## 150 List of Equipment

### 150.1 General Information

1. The basic Key Service Unit (ES-16-2 KSU) comes equipped with the 3 common control cards (CP-NA, IO-N, TNG-NA), and Installation Service Manual (ND-16982) and a mounting template. All other equipment must be ordered according to the application requirements. All customer-provided optional equipment (external amplifier, MOH music source, speakers, etc.) must be locally provided.

### 150.2 Equipment Description

1. ES-16-2 KSU (Key Service Unit) is the basic Key Service Unit. This steel cabinet houses the common cards and various Key Telephone Units (KTUs). It provides service for up to 8 CO/PBX lines, 16 stations, 2 DSS/BLFs, 1 BLF (SEE NOTE) and various system options. Connections to all CO/PBX lines, the first 16 stations, and most options are made via this KSU.
2. ES-48/32-1 KSU is the Expansion Key Service Unit. This cabinet is not a stand-alone unit and must be used in conjunction with the ES-16-1. The first ES-48/32-1 KSU is mounted on top of the ES-16-2 KSU and expands the total system capacity to up to 12 CO/PBX lines, 32 stations, 2 DSS/BLF consoles and 4 BLFs (SEE NOTE). It houses various KTUs and provides connections to the second group of 16 stations.

The second ES-48/32-1 KSU is mounted on top of the first ES-48/32-1 KSU and expands the total system capacity to up to 16 CO/PBX lines, 48 stations, 2 DSS/BLF consoles and 4 BLFs (SEE NOTE). It houses various KTUs and provides connections to the third group of 16 stations.

**Note:** DSS/BLFs can be replaced by BLFs.

3. PS-16-1 PSU is the power supply required for the ES-16-( ) KSU. The PS-16-1 mounts externally and supplies the required voltages to KTUs installed within, and station equipment connected to the ES-16-( ) KSU. The PS-16-1 also provides a mounting space to install the RSG-N Unit when the ringing supply generator is required.
4. PS-48/32-1 PSU is the power supply required for each ES-48/32-1 KSU. The first PS-48/32-1 PSU is mounted on top of the PS-16-1 PSU. The second PS-48/32-1 PSU is mounted on top of the first PS-48/32-1 PSU.

5. RSG-N Unit is a ringing supply generator unit. It is required for signaling single line telephones: if there are no single line telephones in the system, it is not required. This unit mounts internally in the PS-16-1 Unit.

6. CP-NA KTU (Central Processing Key Telephone Unit) is the heart of the Electra-16/48 Key Telephone System. It is composed of three sections: the Central Processor, the ROM section for storing programmed instructions, and the RAM section for storing data. The CP-NA KTU contains an 8085A 8-bit microprocessor, that executes many different functions under the control of a sequence of programmed instruction stored in ROM. This KTU is provided in the ES-16-2 KSU.

**Note:** The CP-NA and the RAM-N KTUs can not be simultaneously installed in an Electra-16/48 system. The CP-NA has rendered the RAM-N redundant by incorporating the memory previously located on the RAM-N onto itself. Remove the RAM-N when installing a CP-NA: the combination of the two KTUs will render the system inoperative.

7. IO-N KTU (Input/Output Key Telephone Unit) is composed of two sections: the card control section and the RAM section. The card control I/O section distributes the data signals sent to or from the CPU. The RAM section is an expansion of 3K bytes for the CPU.
8. TNG-NA KTU (Tone Generator and Input/Output Key Telephone unit) is composed of three sections: the tone source section which generates various frequencies needed for system operation. Some of the tones generated are:

1. CO/PBX Ring Tone
2. ICM Dial Tone
3. Call Waiting Tone
4. SLT Hold Tone

The switch section consists of crosspoint switches and amplifiers for connection of dial, hold, and other tones to stations, and intercom paths to external and internal paging. The input/output section stores lamp and button data shared by the KSIs and CPU.

A connector is provided to allow installation of the SMDS-N KTU for recording call data.

9. COI-N KTU (Central Office Line Interface Key Telephone Unit) contains circuitry for CO/PBX ring detection, hold, and control functions. Each COI-N KTU provides circuits to serve up to 4 CO/PBX lines.
10. DC-N KTU (Dial Pulse Converter Key Telephone Unit) sends rotary dial pulse signaling to CO/PBX lines in accordance with dialing at station sets. Each DC-N KTU provides circuits to serve up to 4 CO/PBX lines. DC-N KTUs and MFC-N KTUs can be mixed in a system.
11. MFC-N KTU (Dual-Tone Multi-Frequency Converter Key Telephone Unit) sends DTMF dial signaling to CO/PBX lines in accordance with dialing at station sets. Each MFC-N KTU provides circuits to serve up to 4 CO/PBX lines. MFC-N KTUs and DC-N KTUs can be mixed in a system.
12. KSI-N KTU (Key Set Interface Key Telephone Unit) provides data control and voice service to the Electronic Key Telephone Sets (ET-8-2 and ET-16-1). Each KSI-N KTU provides circuits to serve up to 4 Electronic Key Telephone Sets.
13. SLI-N KTU (Single Line Telephone Interface Key Telephone Unit) contains loop status detection and provides control and voice service to DTMF dial single line telephone sets. Each SLI-N KTU provides circuits to serve up to 4 single line telephone sets.
14. MFR-N (Dual-Tone Multi-Frequency Receiver Key Telephone Unit) provides DTMF signal detection and translation circuits for alerting the processor to dialed requests for service from the DTMF dial single line telephones. Each MFR-N KTU provides 2 receiver circuits which are shared by single line telephones in the system: if there are no single line telephone sets in the system, MFR-N KTUs are not required.
15. SW-N KTU (Switch Matrix Key Telephone Unit) contains a 16 x 16 semi-conductor switching array for connection of station sets to intercom paths, CO/PBX lines, and tone trunks. Each SW-N serves 16 stations and a varying number of CO/PBX lines, intercom paths and tone trunks.
16. ET-8-2 Telephone is a fully-modular electronic key telephone set with 35 nonlocking buttons. Of these, 8 buttons are CO/PBX buttons, 7 buttons are function buttons and 20 buttons are used for the DSS (Direct Station Selection) and station speed dialing features. A switch is provided to allow assignment of the 8 CO/PBX buttons as either CO/PBX lines 1 ~ 8 or CO/PBX lines 9 ~ 16. Up to 20 buttons may be used for the DSS function and at least 10 buttons may be used for station speed dialing to a maximum of 20 buttons. This telephone requires 2 pair cabling to the Main Distribution Frame (MDF).
17. ET-16-1 Telephone is a fully-modular electronic key telephone set with 43 nonlocking buttons. Of these, 16 buttons are CO/PBX line buttons, 7 buttons are function buttons and 20 buttons are used for the DSS and station speed dialing features. Up to 20 buttons may be used for the DSS function and at least 10 buttons may be used for station speed dialing to a maximum of 20 buttons. This telephone requires 2 pair cabling to the Main Distribution Frame (MDF).
18. Single Line Telephone Sets must be provided locally. Only DTMF dial single line telephones will be able to dial in this system. Use of single line telephones requires MFR-N KTU(s), SLI-N KTU(s) and a RSG-N Unit.
19. PFT-NA (Power Failure Transfer Key Telephone Unit A) provides for transfer of the first 8 CO/PBX line in the system to additional locally-provided single line telephone sets during power failure. In certain configurations, single line telephone sets installed in the system can also be used for power failure telephone sets. This is described in Section 270, "Installing Options" of this manual.
20. PFT-NB (Power Failure Transfer Key Telephone Unit B) provides for transfer of 4 additional CO/PBX lines in the system to additional locally-provided single line telephone sets during power failure. This KTU, for installation in both ES-48/32-1 KSUs when a COI-N KTU is installed in them, is optional. This is described in Section 270, "Installing Options" of this manual.
21. EP-N KTU (External Paging Key Telephone Unit) contains a 3-watt amplifier and a control circuit for 3-zone selection for external paging. For applications where 3-watts is insufficient, a high power amplifier and three switching relays can be locally provided in addition to the EP-N KTU. This KTU is installed in the ES-16-1 KSU and is optional. The External Chime control feature is also provided by this KTU.

22. AHR-N KTU (Automatic Hold Release Key Telephone Unit) serves up to 8 CO/PBX lines. This KTU will recognize a timed disconnect signal sent from an exchange when an outside party has abandoned a call. If that call is on hold, the AHR-N will release that line from hold condition and restore it to idle condition. It is necessary that an exchange send a timed disconnect signal for this KTU to work. One AHR-N KTU can be installed in the ES-16-( ) KSU and a second AHR-N in the first (lower) ES-48/32-1 KSU. These KTUs are optional.
23. SMDS-N KTU (Station Message Detail Service Key Telephone Unit) provides detailed call records for outgoing, incoming, and transferred CO/PBX calls. A printer or other peripheral device must be connected to the RS-232C connector provided. The time and date clock is protected from power loss by an attached battery. Data output speed ranges from 150 to 2400 baud and is set by switch. The TNG-NA and CP-NA are required for SMDS-N KTU to function.
24. DSI-N KTU (Direct Station Selection Console Interface Key Telephone Unit) provides both-way data control for up to two ED-48-1 Direct Station Selection/Busy Lamp Fields and four EB-48-1 Busy Lamp Fields. Each DSS/BLF console can be replaced with a BLF. The DSI-N KTU mounts in the ES-16-1 KSU. The DSS/BLF consoles, the Busy Lamp Fields and the DSI-N KTU are optional.
25. ED-48-1 DSS/BLF is an Electronic Direct Station Selection/Busy Lamp Field Console (DSS/BLF) with 60 non-locking buttons. 48 buttons are direct station selection buttons and 12 buttons are function buttons. Each station button and function button incorporates an LED to display station or function status. Each station button has another associated LED for message waiting status indication. The ED-48-1 comes equipped with a local power supply and requires 1 pair cabling to the Main Distribution Frame (MDF).
26. EB-48-1 BLF is an Electronic Busy Lamp Field with 48 LEDs to show station status. The EB-48-1 comes equipped with a local power supply and requires 1 pair cabling to the Main Distribution Frame (MDF).

**Note:** *The first DSS/BLF console is associated with station 101. The second DSS/BLF console is associated with station 102.*

## 160 System Configuration

### 160.1 To Determine Required Equipment

1. Determine how many electronic key telephones are required. (At least one Key Telephone, Station 101, is required as an attendant telephone for programming purposes). Divide this number by 4. If the result is not a whole number round the result off to the next higher whole number. This is the number of KSI-N KTUs required.
2. Determine how many single line telephones are required. Divide this number by 4. If the result is not a whole number, round the result off to the next higher whole number. This is the number of SLI-N KTUs required.
3. Add the results of Step 1 and Step 2 to determine which of the following tables, A, B and C to use. See table 160-3.
4. Determine how many CO/PBX lines are required. The result will tell you which line of the selected table to use.
5. MFR quantities are dependent on the number of single line telephones installed.

**Table 160-1 MFR-N Recommended Quantities**

Single Line Sets	MFR-N KTUs Recommended
0	0
1 ~ 4	1
4 ~ 16	2
16 ~ 48	3

This table is only for recommended quantities of MFR-N KTUs. The actual quantity for satisfactory service would vary depending on the amount of single line traffic.

### 160.2 To Determine Optional Equipment

1. Required KTUs for options are:

**Table 160-2**

Option	KTU	Max. No.
Power Failure Transfer	PFT-A, PFT-B	See Table 160-3
Automatic Hold Release	AHR-N	See Table 160-3
External Zone Paging	EP-N	1
DSS/BLF Consoles and/or BLFs	DSI-N	1
Station Message Detail Service	SMDS-N	1

**Note:** *CP-NA and TNG-NA are required for SMDS-N KTU to function.*

**Table 160-3 Required KTU Table (Power Failure Transfer and Automatic Hold Release Options included)**

**TABLE A: Combined Total of KSI-N and SLI-N is 4 or less.**

CO/PBX Lines	ICM Paths	ES-16-2	ES-48/32-1	PS-16-1	PS-48/32-1	RSG-N	COI-N	DC-N/ MFC-N	SW-N	PFT-A (Optional)	PFT-B (Optional)	AHR-N (Optional)
1 ~ 4	3	1	0	1	0	Note 1	1	1	1	1	0	1
5 ~ 8	5	1	0	1	0	Note 1	2	2	2	1	0	1
9 ~ 12	5	1	1	1	1	Note 1	3	3	2	1	1	2
13 ~ 16	5	1	2	1	2	Note 1	4	4	2	1	2	2

**TABLE B: Combined Total of KSI-N and SLI-N is 5 ~ 8.**

CO/PBX Lines	ICM Paths	ES-16-2	ES-48/32-1	PS-16-1	PS-48/32-1	RSG-N	COI-N	DC-N/ MFC-N	SW-N	PFT-A (Optional)	PFT-B (Optional)	AHR-N (Optional)
1 ~ 4	3	1	1	1	1	Note 1	1	1	2	1	0	1
5 ~ 8	5	1	1	1	1	Note 1	2	2	4	1	0	1
9 ~ 12	5	1	1	1	1	Note 1	3	3	4	1	1	2
13 ~ 16	5	1	2	1	2	Note 1	4	4	4	1	2	2

**TABLE C: Combined Total of KSI-N and SLI-N is 9 ~ 12.**

CO/PBX Lines	ICM Paths	ES-16-2	ES-48/32-1	PS-16-1	PS-48/32-1	RSG-N	COI-N	DC-N/ MFC-N	SW-N	PFT-A (Optional)	PFT-B (Optional)	AHR-N (Optional)
1 ~ 4	3	1	2	1	2	Note 1	1	1	3	1	0	1
5 ~ 8	5	1	2	1	2	Note 1	2	2	6	1	0	1
9 ~ 12	5	1	2	1	2	Note 1	3	3	6	1	1	2
13 ~ 16	5	1	2	1	2	Note 1	4	4	6	1	2	2

**Note 1:** When any SLI-N KTU is installed RSG-N Ringing Supply Generator is required.



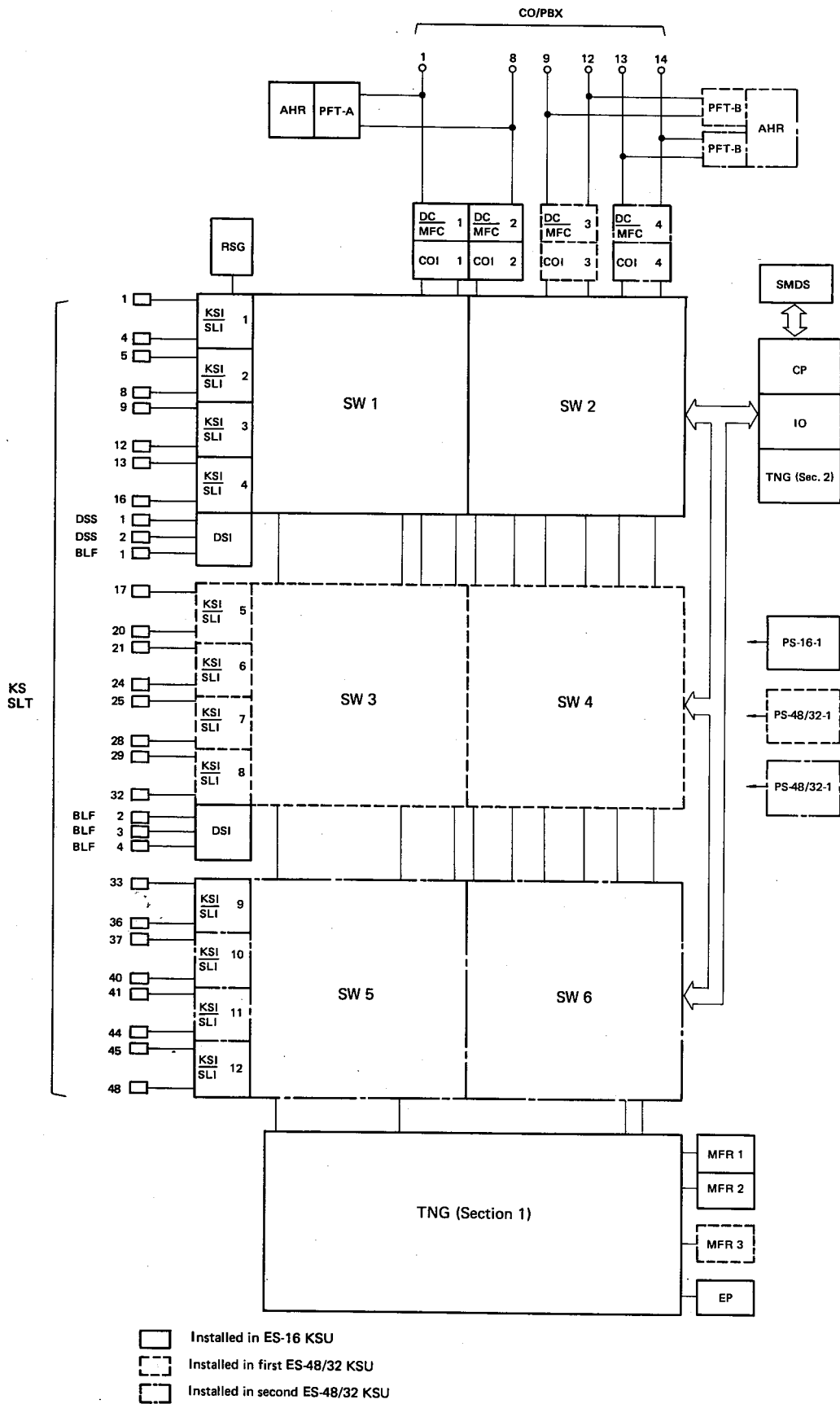

**Fig. 160-1 System Block Diagram**

210 Installing the Central Equipment

210.1 Mounting the KSU(s)

1. Use the template provided with ES-16-( ) KSU to layout KSU(s) position(s). Install fasteners appropriate for wall mounting in positions shown on template. KSU(s) must be mounted correctly for proper operation.

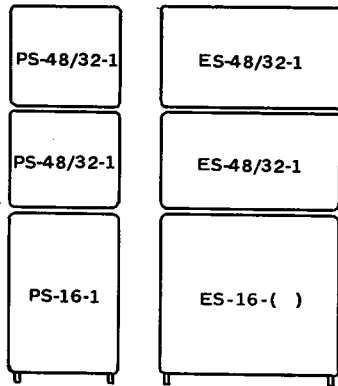

Fig. 210-1 Front View of Properly Mounted KSUs and PSUs

2. To provide for cable feeds when a ES-48/32-1 is to be installed, loosen the plate on right side of the top of the ES-16-( ) and rotate the plate until it aligns with the index tab; then secure it to the panel of the ES-16-( ).

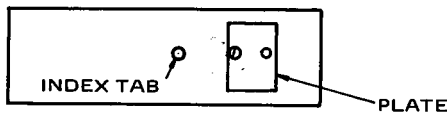

Fig. 210-2 Top View of ES-16-( ) or ES-48/32-1 KSU

3. If the second ES-48/32-1 is to be installed, repeat Step 2 immediately above with the first ES-48/32-1.
4. Using the mounting slots provided on the ES-16-( ) mount the KSU on the fasteners and firmly connect to wall surface.
5. If the first ES-48/32-1 is to be installed, engage the flanges on the bottom of the ES-48/32-1 in the slots on the top of the ES-16-( ). Firmly connect the ES-48/32-1 to the wall surface.

6. If the second ES-48/32-1 is to be installed, repeat Step 5 immediately above with the second ES-48/32-1 as the top expansion cabinet and first ES-48/32-1 as the bottom expansion cabinet.

210.2 Mounting the Power Supplies and Ring Generator

**Note:** The PS-16-1 Power Cord is to remain unplugged during this process. The PS-16-1 Power Switch should be OFF and its Power Indicator Lamps should be OFF.

1. Use the template provided with ES-16-( ) to layout position(s). Install fasteners appropriate for wall mounting in positions shown on template. Power Supplies must be mounted on left side of KSU(s).
2. To provide for AC power cable feeds when a PS-48/32-1 is to be installed, loosen the plate on the left side of the top of the PS-16-1 and rotate the plate until it aligns with the index tab; then secure it to the top panel of the PS-16-1.

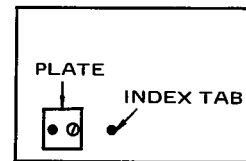

Fig. 210-3 Top View of PS-16-1 or PS-48/32-1 PSU

3. If a second PS-48/32-1 is to be installed, repeat Step 2 immediately above with the first PS-48/32-1.
4. Using the mounting slots provided on the PS-16-1, mount the Power Supply on the fasteners and firmly connect to wall surface.
5. If the first PS-48/32-1 is to be installed, engage the flanges on the bottom of the PS-48/32-1 in the slots on the top of the PS-16-1. Firmly connect the PS-48/32-1 to the wall surface.
6. If the second PS-48/32-1 is to be installed, repeat Step 5 immediately above with second PS-48/32-1 as the top Power Supply and first PS-48/32-1 as the bottom Power Supply.
7. Mount the RSG-N Unit (when required) in the top portion of the PS-16-1. Use the screws provided to firmly secure the RSG-N to the PS-16-1.

### 210.3 Floor Mounting the KSU(s) and PSU(s)

The KSUs and PSUs are designed for wall mounting but floor mounting by stacking KSUs and PSUs can be performed.

1. There have been 2 methods of interconnecting the connectors mounted in the ES-16-( ) and ES-48/32-1 KSUs: by wire warp connections and by a printed wire board (PWB). These various KSUs are compatible by different means of ensuring the stability of the KSU stack are required.

The possible configurations are:

**Table 210-1 Method of Stabilizing KSU Stack**

Upper Unit	Wirewrap	Wirewrap	PWB
Lower Unit	Wirewrap	PWB	Wirewrap or PWB
Stabilizing Method	Reversed Bottom Flanges	Type A Clamp	Type B Clamp

#### 2. Stacking Wirewrap KSU on Wirewrap KSU

- Reposition the metal flanges on the bottom of the ES-48/32-1 by removing the screws and installing the flanges in the forward position.
- Engage the flanges on the bottom of the ES-48/32-1 into the slots of the ES-16-2 or lower ES-48/32-1 KSU and push upper unit gently forward to seat flanges secondly.

#### 3. Stacking Wirewrap KSU on PWB KSU (see Fig. 210-4)

- Remove 2 screws from top of each side of PWB KSU. Attach type B clamps to PWB KSU using same screws and screwholes.
- Remove 2 screws from bottom of each side of wire-wrap KSU, stack on PWB KSU and reinstall screws in same screwholes thorough holes in type B clamps.

#### 4. Stacking PWB KSU on wirewrap on PWB KSU. (see Fig. 210-4)

- Remove 2 screws from top of each side of KSU on which PWB ES-48/32-1 KSU is to be stacked. Install type B clamps using same screws and screwholes of type B clamps.

5. Connecting the KSU and the PSU stacks. A metal bar is provided with the ES-48/32-1 KSU to tie the power supplies to the KSUs. This bar provides stability and can be used only when floor mounting KSUs. With the screws provided with the support bar, connect the support bar to the uppermost KSU and PSU. Holes are provided on each unit for this purpose. Refer to Fig. 210-5.

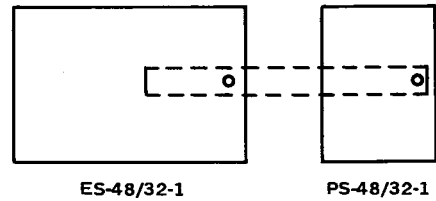

**Fig. 210-5 Rear View of KSU and PSU**

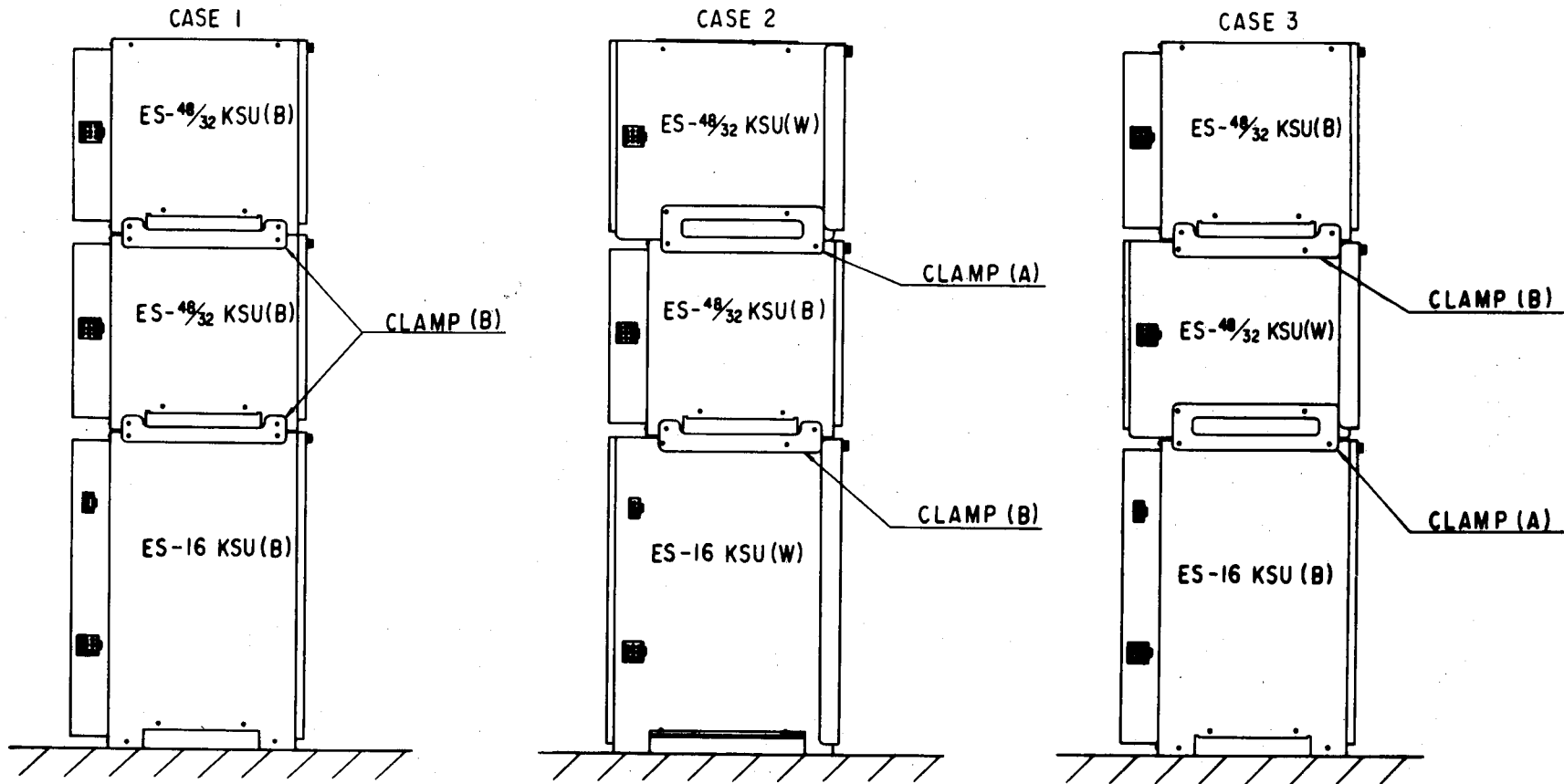

**Note 1:**

Desig	Method of interconnection
W	Wirewrap
B	Printed Wire Board

**Note 2:**

ES-16 KSU (B)	ES-16 KSU (W)	ES-48/32 KSU (B)	ES-48/32 KSU (W)
ES-16-1 KSU F version and ES-16-2 KSU	ES-16-1 KSU A to E version	ES-48/32-1 KSU C and later versions	ES-48/32-1 KSU A and B version

**Note 3:** CLAMPs Type (A) and Type (B) are connected using the same screws already installed on each KSU.

**Note 4:** 2 CLAMPs Type (A) are attached in ES-16 KSU (B) and 2 CLAMPs Type (B) are attached in ES-48/32 KSU (B).

**Fig. 210-4 Connection of Type (A) and Type (B) Clamps to Allow Floor Mount Installation of KSUs**

## 220 Interconnecting KSUs

1. When ES-48/32-1 KSUs are installed, install the flat cables packed with each ES-48/32-1 between KSU connectors as shown below:

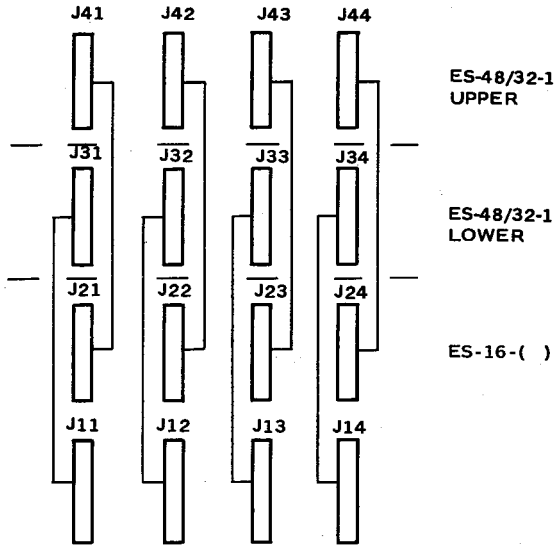

Fig. 220-1 Flat Cable Connections between KSUs

Table 220-1 Flat Cable Connection

From KSU	Connector	Connector	To KSU
ES-16-( )	J11	J31	Lower ES-48/32-1
	J12	J32	
	J13	J33	
	J14	J34	
ES-16-( )	J21	J41	Upper ES-48/32-1
	J22	J42	
	J23	J43	
	J24	J44	

The connectors provided to receive these flat cables have a guide notch so these cables cannot be reversed. The flat cables can, however, be used between wrong connectors: carefully check using the above information.

2. When ES-48/32-1 KSUs are installed, connect the 3 conductor loop-ended cable packed with each ES-48/32-1 between KSU screw terminal connector blocks as shown below. The connector blocks are located on the right side of each KSU and provide Ring Signal (for single line telephones) from the RSG-N Unit to the ES-48/32-1 KSUs.

If there is no SLI-N KTU installed in either ES-48/32-1 the 3 conductor cable is not required but should be installed for future use.

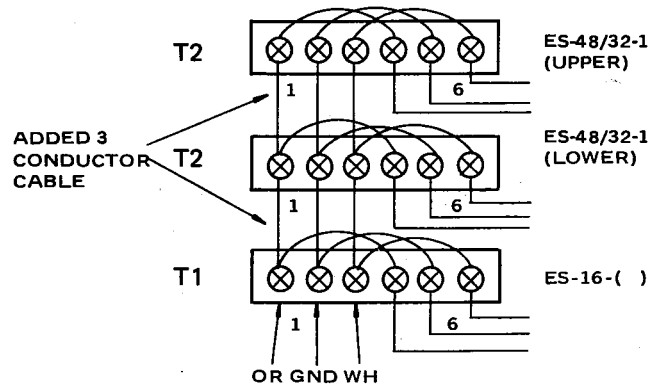

Fig. 220-2 3 Conductor Ring Signal Connections between KSUs

## 230 Connecting and Testing Power Supplies

**Note:** Before proceeding, ensure that the PS-16-1 Power Cord is unplugged. The PS-16-1 Power Switch should be OFF and its Power Indicator Lamps should be OFF.

1. Locate 3-pin connector-ended AC power input cables from each Power Supply and RSG-N and connect to PS-16-1 connectors as below:

**Table 230-1 Connection of AC Power Input Cables**

UNIT	LOCATION
PS-16-1	C1
Lower PS-48/32-1	C2
Upper PS-48/32-1	C3
RSG-N	C4

2. The 3-pin connector-ended cables from each power unit may be connected to any of the "C" locations provided on PS-16-1. For uniformity it is recommended that the above sequence in Table 230-1 be used.

If it has not been verified that the AC outlet is supplying 117V AC and provides conduit ground, verify at this time. If there is a problem with the AC voltage, have it corrected. If there is no conduit ground, provide alternate ground as explained in Section 120, "Grounding Requirements", of this manual.

3. Plug AC cord into AC outlet. Turn PS-16-1 Power Switch ON. The PS-16-1 Power Indicator Lamps should light. Using a voltmeter a check can now be made of the output voltage of the PS-16-1 Unit and the RSG-N Unit. When installed, check the output voltage of each PS-48/32-1 Unit.
4. DC output voltages can be read on the 9-pin connector of each PS-16-1 and PS-48/32-1 according to the figure below:

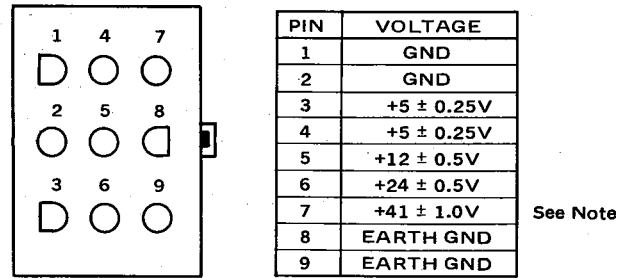

**Fig. 230-1 Front View of 9-Pin Connector of each PS-16-1 and PS-48/32-1**

This reading is of voltage without load. Compare with Section 140, "Specifications", of this manual.

**Note:** +41 Volt Reading will measure low without load, approximately 25 ~ 30V.

5. AC output voltage of the RSG-N Unit can be read on the output 3-pin connector of the RSG-N Unit according to the figure below. Approximately 100V RMS should be read across pins 1 and 3.

**Note:** Most voltmeters will not accurately measure this voltage due to the frequency.

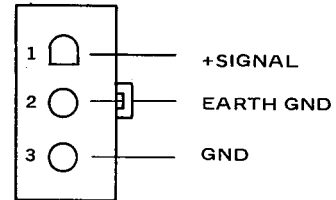
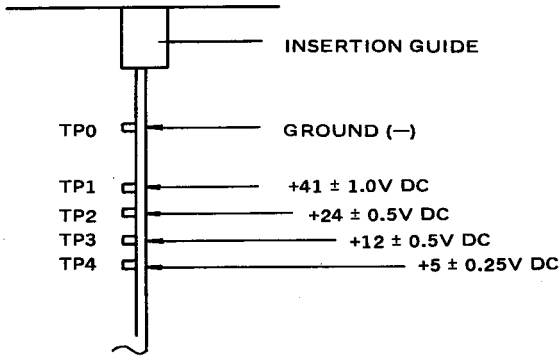

**Fig. 230-2 Front View of 3-Pin Connector of RSG-N**

6. Turn the PS-16-1 Power Switch OFF.

**Note:** Verify that Step 6 has been completed before proceeding. Verify that PS-16-1 Power Indicator Lamps are OFF.

7. Connect the 9-pin connector-ended cable found with each Power Supply Unit to the 9-pin connector of each corresponding KSU. Connect the 3-pin connector-ended cable found with the RSG-N Unit to the 3-pin connector of the PS-16-1.
8. Turn the PS-16-1 Power Switch ON. DC voltages (under load) can now be read on the voltage test pins on the upper portion of the TNG-N KTU.



**Fig. 230-3 Front View of Installed TNG**

9. When an ES-48/32-1 KSU(s) is installed the DC voltages (under load) can be read on the voltage test pins on the SW-N KTU(s). The SW-N(s) installed in the first ES-48/32-1 KSU can be used to measure the DC voltages of the first PS-48/32-1 PSU.

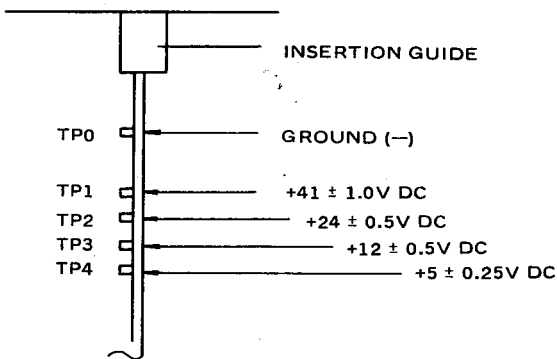

**Fig. 230-4 Front View of Installed SW**

10. Turn the PS-16-1 Power Switch OFF before proceeding with installation.
11. When a fuse is blown, refer to Section 140, "Fuse Replacement" of this manual.

## 240 INSTALLATION OF KTUs

**Note:** *The following KTUs CANNOT be inserted or removed with power on:*

<i>CP-N and CP-NA</i>	<i>KSI-N</i>
<i>IO-N</i>	<i>DSI-N</i>
<i>TNG-N and TNG-NA</i>	<i>SMDS-N</i>

*All these KTUs either contain a microprocessor or are intimately connected with system operation.*

### 240.1 General Information

1. The KTUs specified directly above cannot be inserted or removed with power on. While other KTUs can, it is recommended that power be OFF during installation (there is no service to interrupt) and during maintenance unless this will seriously inconvenience the user. This will prevent accidental damage to equipment.
2. The KTUs used in the Electra-16/48 system make extensive use of CMOS technology. Care must be taken to avoid static discharge when handling these KTUs.
3. KTUs are provided with a guide slot to prevent misinstallation. KTU connectors are provided with a guide plug. These guide plugs should be left installed.
4. The ES-16-2 and ES-16-1 are different due to the common KTUs forward installed in each. The ES-16-2 contains a CP-NA and a TNG-NA. The ES-16-1 contains a CP-N and a TNG-N. The CP-NA provides an enhanced feature package and the combination of CP-NA, TNG-NA and SMDS-N is required for Station Message Detail Service feature.

**Note:** *The memory which was originally located on the RAM-N KTU has been relocated and is on the CP-NA is installed NO RAM-N KTU can be installed: installation of both of these KTUs will render the Electra-16/48 system inoperative.*

### 240.2 Order of KTU Installation

1. Install the basic KTUs first. These are the COI-N, DC-N and/or MFC-N, KSI-N and/or SLI-N, MFR-N, and SW-N. In most cases the rule to follow is to install them in strict numerical order: according to the KSU slot designation numbers. (e.g. COI 1, then COI 2, then COI3, last COI4.)  
The rule for installing the basic KTUs is:

**Table 240-1 Installing Basic KTUs**

COI-N	In numerical order by slot designation number.
DC-N or MFC-N	To match COI-N slots used: DC-N for rotary and MFC-N for DTMF signals.
KSI-N or SLI-N	In numerical order by slot designation except as in A below.
MFR-N	In numerical order by slot designation number.
SW-N	As in B below.

A. Stations 101 and 102 are designated attendant positions. These stations are supported by the KTU in KSI/SLI 1 slot. Only a key telephone installed at either or both of these locations can program this system. The DSS/BLF consoles will only work in conjunction with these same key telephones. To program the system, always install a KSI in KSI/SLI 1 slot.

B. The rule for installing SW-N KTUs is:

**Table 240-2 Installing SW-N KTUs**

Install SW-N in Slot	When
SW1	Any KTU in KSI/SLI 1 – 4.
SW2	SW1 installed and any COI-N in COI 2 – 4 slots or more than 3 ICM paths desired.
SW3	Any KTU in KSI/SLI 5 – 8.
SW4	SW3 installed and any COI-N in COI 2 – 4 slots or more than 3 ICM paths desired.
SW5	Any KTU in KSI/SLI 9 – 12.
SW6	SW5 installed and any COI-N in COI 3 – 4 slots or more than 3 ICM paths desired.

**240.3 Installing Basic KTUs**

1. COI-N and SLI-N KTUs

When installing COI-N and SLI-N KTUs there will often be more KTU circuits installed (since there are 4 per KTU) than will actually be used.

In the case of COI-N KTUs any non-used circuits should be programmed as “not installed” when programming for CO Line class. See Section 300 “Programming” of this manual for instructions on programming CO Line class.

In the case of SLI-N KTUs there is a DIP switch assembly mounted on the KTU. Turn the switches OFF for those circuits not used.

Failure to complete these instructions concerning COI-N and SLI-N KTUs will not degrade system performance but may cause confusion to the system user when attempts to access unconnected CO/PBX lines or single line sets are made.

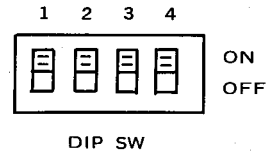

**Fig. 240-1 SLI-N DIP SW**

2. KSI-N KTU

There are four fuses (125V 0.5A) located on the KSI-N KTU: one fuse for each KSI position. The fuse provides protection for cabling errors on the data transmission pairs (DT and DR).

When a fuse is blown, refer to Section 140, “Fuse Replacement” of this manual.

3. AHR-N KTU

When an AHR-N KTU(s) (Automatic Hold Release) is installed, the S1 switch on each COI-N KTU should be set to the AHR position.

When the AHR-N(s) is not installed, the switch should be set to the N position.

This option will release the line on hold when the outside party has abandoned the call. For this option to operate, a timed disconnect signal of more than 150 milliseconds must be provided from the CO or PBX (it will not recognize a reversal of polarity).

One AHR-N KTU can be installed in the ES-16( ) KSU, and it serves the first 8 CO/PBX lines (COI-1 and COI-2). The second AHR-N is installed in the first (lower) ES-48/32-1 KSU, and it serves CO/PBX lines 9 thru 16 (COI-3 and COI-4).



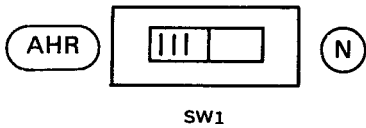

Fig. 240-2 COI-N AHR Switch

#### 240.4 Installing Common KTUs

##### 1. CP-NA KTU

Before programming the Network Plan Memory (NPM) ensure that the SW6 switch located in the CP-NA KTU is set to the ON position. This will provide battery back-up for the NPM, speed dial, and last number dialed memory when power is lost to the KSU.

If there is a power failure and the switch is left in the OFF position, the system will lose its working memory and return to the Resident System program.

When the CP-NA KTU is removed for long-term storage, set the SW6 switch to the OFF position. This will prevent the battery from constantly discharging until it is no longer capable of holding a charge.

The battery when fully charged, will protect the memory for approximately 60 days.

**Note:** *The battery only supplies back-up to the volatile memory of the CP-NA. It will not provide battery back-up to the Electra 16/48 system during a power failure.*

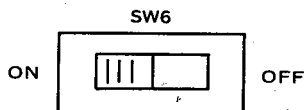

Fig. 240-3 CP-NA Switch for Volatile Memory

On the CP-NA KTU is a momentary switch for system reset. Depressing the reset switch causes any program changes to enter the working program and ends all system operation in progress.

#### 240.5 Installing Optional KTUs

##### 1. PFT-A, PFT-B, EP-N, AHR-N, DSI-N and SMDS-N KTUs

Install optional KTUs as required for each application. Option KTUs include: PFT-A, PFT-B, EP-N, AHR-N, DSI-N, and SMDS-N

Table 240-3 Installing Optional KTUs

KTU	Option
PFT-A	Install in ES-16-( ) for power failure transfer of COI 1 and COI 2.
PFT-B	Install one in first ES-48/32-1 (lower) for power failure transfer of COI 3, one in second ES-48/32-1 (upper) for power failure transfer of COI 4.
EP-N	Install in ES-16-( ) for external paging option.
AHR-N	Install for automatic hold release option, one in ES-16-( ) for COI 1 and 2, one in first ES-48/32-1 (lower) for COI 3 and 4.
DSI-N	Install in ES-16-( ) for DSS/BLF and BLF Consoles.
SMDS-N	Install in ES-16-( ) for Station Message Detail Service.

When SMDS-N is installed switches must be set to assign the baud rate and battery backup for clock and RAM memory.

When EP-N is installed for paging and an external high-powered amplifier is to be installed, it is necessary to set the SW1 switch on the EP-N KTU to the "B" position. See Section 270, "Installing Options", of this manual.

## 240.6 Volume Controls

1. All tones from the built-in speaker in a keyset are controlled at the keyset by adjusting the volume dial in the front of the keyset.
2. To control the buzzer tone of the DSS/BLF Console adjust the volume dial in front of the console.
3. CO and ICM service tones are controlled by adjusting volumes on the TNG-NA KTU.  
Tone level will increase by turning the volume control clockwise. All volumes have been adjusted by the manufacturer. Refer to Table 240-4 shown below for Volume Controls.

**Table 240-4 TNG Volume Controls**

VR 1 (CO)		CO/PBX Ring
VR 2 (DT)	500 Hz	ICM Dial Tone, Busy Tone, Error Tone, Ringback Tone, ICM Signal Tone
VR 3 (CWT)	1200 Hz	Call Waiting Tone, Automatic Hold Recall
VR 4 (HT)	2400 Hz	Override Tone, Single Line Hold Tone
VR 5 (IPG)		Internal Zone Paging

## 250 MDF Installation

### 250.1 CO/PBX Connection

1. The FCC approved USOC number for 50 position miniature ribbon jack for connection of CO lines is RJ21X. The CO lines are to be connected in sequence consecutively within this jack.
2. Whenever possible, for ease of trouble location and correction, use of 66B50 or 66M50 quick-connect type blocks is recommended. Use of bridging clips allows easy separation of systems to determine cause of trouble, CO/PBX side or Electra-16/48 side.
3. The following table 250-1 gives complete information on 50 position connector pin number, lead function, running cable color, circuit designation, associated COI slot, and associated KSU.

### 250.2 Station Cabling Connection

1. The following tables give complete information on KSU, cable, 50 position connection pin number, running cable color, lead designation, station cable color, intercom number assignment, KSI/SLI slot assignment, etc. for all stations. Refer to Tables 250-1, 250-2 and 250-3.

**Table 250-1**  
**CO/PBX Connection Information**  
**P1 Connector & Cable ES-16-( ) KSU**

Pin	Function	Cable Color	Circuit	SLOT	KSU
26 1	1T 1R	WH-BL BL-WH	CO/PBX 1	COI 1	ES-16-( )
27 2	2T 2R	WH-OR OR-WH	CO/PBX 2		
28 3	3T 3R	WH-GN GN-WH	CO/PBX 3		
29 4	4T 4R	WH-BR BR-WH	CO/PBX 4		
30 5	5T 5R	WH-SL SL-WH	CO/PBX 5	COI 2	
31 6	6T 6R	RD-BL BL-RD	CO/PBX 6		
32 7	7T 7R	RD-OR OR-RD	CO/PBX 7		
33 8	8T 8R	RD-GN GN-RD	CO/PBX 8		
34 9	9T 9R	RD-BR BR-RD	CO/PBX 9	COI 3	LOWER ES-48/32-1
35 10	10T 10R	RD-SL SL-RD	CO/PBX 10		
36 11	11T 11R	BK-BL BL-BK	CO/PBX 11		
37 12	12T 12R	BK-OR OR-BK	CO/PBX 12		
38 13	13T 13R	BK-GN GN-BK	CO/PBX 13	COI 4	UPPER ES-48/32-1
39 14	14T 14R	BK-BR BR-BK	CO/PBX 14		
40 15	15T 15R	BK-SL SL-BK	CO/PBX 15		
41 16	16T 16R	YL-BL BL-YL	CO/PBX 16		

The rest of P1 Cable is spare as not used.

**CO/PBX Connection:**

1. FCC approved connector USOC code is RJ21X.
2. Connector-ended cable for CO/PBX lines to plug into ES-16-( ) KSU requires Jack (Female) 50 position miniature ribbon connector.

**Table 250-2 Station Connection Information**  
**J1 – J6 Connectors and Cables ES-16-( ), ES-48/32-1 KSUs**

Pin	Running Cable	Station Cable	Leads		ES-16-( )				ES-48/32-1				ES-48/32-1				
			Key	SLS	SLOT	Cable J1	SLOT	Cable J2	SLOT	Cable J3	SLOT	Cable J4	SLOT	Cable J5	SLOT	Cable J6	
26	WH-BL	GN	VT	T	KSI/ SLI 1	*	STA. 101 (ATT)	KSI/ SLI 3	STA. 109	KSI/ SLI 5	STA. 117	KSI/ SLI 7	STA. 125	KSI/ SLI 9	STA. 133	KSI/ SLI 11	STA. 141
1	BL-WH	RD	VR	R													
27	WH-OR	YL	DT	—													
2	OR-WH	BK	DR	—													
28	WH-GN	GN	VT	T													
3	GN-WH	RD	VR	R													
29	WH-BR	YL	DT	—													
4	BR-WH	BK	DR	—													
30	WH-SL	GN	VT	T	KSI/ SLI 2	*	STA. 102 (ATT)	KSI/ SLI 4	STA. 110	KSI/ SLI 6	STA. 118	KSI/ SLI 8	STA. 126	KSI/ SLI 10	STA. 134	KSI/ SLI 12	STA. 142
5	SL-WH	RD	VR	R													
31	RD-BL	YL	DT	—													
6	BL-RD	BK	DR	—													
32	RD-OR	GN	VT	T													
7	OR-RD	RD	VR	R													
33	RD-GN	YL	DT	—													
8	GN-RD	BK	DR	—													
34	RD-BR	GN	VT	T	KSI/ SLI 2	STA.	KSI/ SLI 4	STA. 113	KSI/ SLI 6	STA. 121	KSI/ SLI 8	STA. 129	KSI/ SLI 10	STA. 137	KSI/ SLI 12	STA. 145	
9	BR-RD	RD	VR	R													
35	RD-SL	YL	DT	—													
10	SL-RD	BK	DR	—													
36	BK-BL	GN	VT	T													
11	BL-BK	RD	VR	R													
37	BK-OR	YL	DT	—													
12	OR-BK	BK	DR	—													
38	BK-GN	GN	VT	T	KSI/ SLI 2	STA.	KSI/ SLI 4	STA. 115	KSI/ SLI 6	STA. 123	KSI/ SLI 8	STA. 131	KSI/ SLI 10	STA. 139	KSI/ SLI 12	STA. 147	
13	GN-BK	RD	VR	R													
39	BK-BR	YL	DT	—													
14	BR-BK	BK	DR	—													
40	BK-SL	GN	VT	T													
15	SL-BK	RD	VR	R													
41	YL-BL	YL	DT	—													
16	BL-YL	BK	DR	—													
						STA.		STA. 116		STA. 124		STA. 132		STA. 140		STA. 148	

\*These stations are attendant stations. One must be an installed keyset for programming purposes. If both are keysets, then both keysets can program. When DSS/BLF consoles are installed, they must be associated with stations 101 and 102.

Table 250-3 Connector Running List

P1				J1				J2				J3				J4				J5				J6			
26	1T	WH-BL	LIN	26	1VT	WH-BL		26	9VT	WH-BL		26	17VT	WH-BL		26	25VT	WH-BL		26	33VT	WH-BL		26	41VT	WH-BL	
1	1R	BL-WH	1	1	1VR	BL-WH	TEL	1	9VR	BL-WH	TEL	1	17VR	BL-WH	TEL	1	25VR	BL-WH	TEL	1	33VR	BL-WH	TEL	1	41VR	BL-WH	TEL
27	2T	WH-OR	LIN	27	1DT	WH-OR	101	27	9DT	WH-OR	109	27	17DT	WH-OR	117	27	25DT	WH-OR	125	27	33DT	WH-OR	133	27	41DT	WH-OR	141
2	2R	OR-WH	2	2	1DR	OR-WH		2	9DR	OR-WH		2	17DR	OR-WH		2	25DR	OR-WH		2	33DR	OR-WH		2	41DR	OR-WH	
28	3T	WH-GN	LIN	28	2VT	WH-GN		28	10VT	WH-GN		28	18VT	WH-GN		28	26VT	WH-GN		28	34VT	WH-GN		28	42VT	WH-GN	
3	3R	GN-WH	3	3	2VR	GN-WH	TEL	3	10VR	GN-WH	TEL	3	18VR	GN-WH	TEL	3	26VR	GN-WH	TEL	3	34VR	GN-WH	TEL	3	42VR	GN-WH	TEL
29	4T	WH-BR	LIN	29	2DT	WH-BR	102	29	10DT	WH-BR	110	29	18DT	WH-BR	118	29	26DT	WH-BR	126	29	34DT	WH-BR	134	29	42DT	WH-BR	142
4	4R	BR-WH	4	4	2DR	BR-WH		4	10DR	BR-WH		4	18DR	BR-WH		4	26DR	BR-WH		4	34DR	BR-WH		4	42DR	BR-WH	
30	5T	WH-SL	LIN	30	3VT	WH-SL		30	11VT	WH-SL		30	19VT	WH-SL		30	27VT	WH-SL		30	35VT	WH-SL		30	43VT	WH-SL	
5	5R	SL-WH	5	5	3VR	SL-WH	TEL	5	11VR	SL-WH	TEL	5	19VR	SL-WH	TEL	5	27VR	SL-WH	TEL	5	35VR	SL-WH	TEL	5	43VR	SL-WH	TEL
31	6T	RD-BL	LIN	31	3DT	RD-BL	103	31	11DT	RD-BL	111	31	19DT	RD-BL	119	31	27DT	RD-BL	127	31	35DT	RD-BL	135	31	43DT	RD-BL	143
6	6R	BL-RD	6	6	3DR	BL-RD		6	11DR	BL-RD		6	19DR	BL-RD		6	27DR	BL-RD		6	35DR	BL-RD		6	43DR	BL-RD	
32	7T	RD-OR	LIN	32	4VT	RD-OR		32	12VT	RD-OR		32	20VT	RD-OR		32	28VT	RD-OR		32	36VT	RD-OR		32	44VT	RD-OR	
7	7R	OR-RD	7	7	4VR	OR-RD	TEL	7	12VR	OR-RD	TEL	7	20VR	OR-RD	TEL	7	28VR	OR-RD	TEL	7	36VR	OR-RD	TEL	7	44VR	OR-RD	TEL
33	8T	RD-GN	LIN	33	4DT	RD-GN	104	33	12DT	RD-GN	112	33	20DT	RD-GN	120	33	28DT	RD-GN	128	33	36DT	RD-GN	136	33	44DT	RD-GN	144
8	8R	GN-RD	8	8	4DR	GN-RD		8	12DR	GN-RD		8	20DR	GN-RD		8	28DR	GN-RD		8	36DR	GN-RD		8	44DR	GN-RD	
34	9T	RD-BR	LIN	34	5VT	RD-BR		34	13VT	RD-BR		34	21VT	RD-BR		34	29VT	RD-BR		34	37VT	RD-BR		34	45VT	RD-BR	
9	9R	BR-RD	9	9	5VR	BR-RD	TEL	9	13VR	BR-RD	TEL	9	21VR	BR-RD	TEL	9	29VR	BR-RD	TEL	9	37VR	BR-RD	TEL	9	45VR	BR-RD	TEL
35	10T	RD-SL	LIN	35	5DT	RD-SL	105	35	13DT	RD-SL	113	35	21DT	RD-SL	121	35	29DT	RD-SL	129	35	37DT	RD-SL	137	35	45DT	RD-SL	145
10	10R	SL-RD	10	10	5DR	SL-RD		10	13DR	SL-RD		10	21DR	SL-RD		10	29DR	SL-RD		10	37DR	SL-RD		10	45DR	SL-RD	
36	11T	BK-BL	LIN	36	6VT	BK-BL		36	14VT	BK-BL		36	22VT	BK-BL		36	30VT	BK-BL		36	38VT	BK-BL		36	46VT	BK-BL	
11	11R	BL-BK	11	11	6VR	BL-BK	TEL	11	14VR	BL-BK	TEL	11	22VR	BL-BK	TEL	11	30VR	BL-BK	TEL	11	38VR	BL-BK	TEL	11	46VR	BL-BK	TEL
37	12T	BK-OR	LIN	37	6DT	BK-OR	106	37	14DT	BK-OR	114	37	22DT	BK-OR	122	37	30DT	BK-OR	138	37	38DT	BK-OR	138	37	46DT	BK-OR	146
12	12R	OR-BK	12	12	6DR	OR-BK		12	14DR	OR-BK		12	22DR	OR-BK		12	30DR	OR-BK		12	38DR	OR-BK		12	46DR	OR-BK	
38	13T	BK-GN	LIN	38	7VT	BK-GN		38	15VT	BK-GN		38	23VT	BK-GN		38	31VT	BK-GN		38	39VT	BK-GN		38	47VT	BK-GN	
13	13R	GN-BK	13	13	7VR	GN-BK	TEL	13	15VR	GN-BK	TEL	13	23VR	GN-BK	TEL	13	31VR	GN-BK	TEL	13	39VR	GN-BK	TEL	13	47VR	GN-BK	TEL
39	14T	BK-BR	LIN	39	7DT	BK-BR	107	39	15DT	BK-BR	115	39	23DT	BK-BR	123	39	31DT	BK-BR	131	39	39DT	BK-BR	139	39	47DT	BK-BR	147
14	14R	BR-BK	14	14	7DR	BR-BK		14	15DR	BR-BK		14	23DR	BR-BK		14	31DR	BR-BK		14	39DR	BR-BK		14	47DR	BR-BK	
40	15T	BK-SL	LIN	40	8VT	BK-SL		40	16VT	BK-SL		40	24VT	BK-SL		40	32VT	BK-SL		40	40VT	BK-SL		40	48VT	BK-SL	
15	15R	SL-BK	15	15	8VR	SL-BK	TEL	15	16VR	SL-BK	TEL	15	24VR	SL-BK	TEL	15	32VR	SL-BK	TEL	15	40VR	SL-BK	TEL	15	48VR	SL-BK	TEL
41	16T	YL-BL	LIN	41	8DT	YL-BL	108	41	16DT	YL-BL	116	41	24DT	YL-BL	124	41	32DT	YL-BL	132	41	40DT	YL-BL	140	41	48DT	YL-BL	148
16	16R	BL-YL	16	16	8DR	BL-YL		16	16DR	BL-YL		16	24DR	BL-YL		16	32DR	BL-YL		16	40DR	BL-YL		16	48DR	BL-YL	
42		YL-OR		42	1DBT	YL-OR	DSS 1	42	3BT	YL-OR	BLF 3	42	4BT	YL-OR	BLF 4	42		YL-OR		42		YL-OR		42		YL-OR	
17		OR-YL		17	1DBR	OR-YL	BLF	17	3BR	OR-YL		17	4BR	OR-YL		17		OR-YL		17		OR-YL		17		OR-YL	
43		YL-GN		43	2DBT	YL-GN	DSS 2	43	1T	YL-GN	PF	43	5BT	YL-GN	BLF 5	43		YL-GN		43		YL-GN		43		YL-GN	
18		GN-YL		18	2DBR	GN-YL	BLF	18	1R	GN-YL	SLT 1	18	5BR	GN-YL		18		GN-YL		18		GN-YL		18		GN-YL	
44		YL-BR		44	EPC1	YL-BR	EXT	44	2T	YL-BR	PF	44	6BT	YL-BR	BLF 6	44		YL-BR		44		YL-BR		44		YL-BR	
19		BR-YL		19	EPC2	BR-YL	PAGE	19	2R	BR-YL	SLT 2	19	6BR	BR-YL		19		BR-YL		19		BR-YL		19		BR-YL	
45		YL-SL		45	EPC3	YL-SL	CONTROL	45	3T	YL-SL	PF	45		YL-SL		45		YL-SL		45		YL-SL		45		YL-SL	
20		SL-YL		20	+24	SL-YL		20	3R	SL-YL	SLT3	20		SL-YL		20		SL-YL		20		SL-YL		20		SL-YL	
46		VI-BL		46	EPI	VI-BL	EXT.PAGE	46	4T	VI-BL	PF	46	9T	VI-BL	PF	46		VI-BL		46	13T	VI-BL	PF	46		VI-BL	
21		BL-VI		21	GND	BL-VI	OUT	21	4R	BL-VI	SLT4	21	9R	BL-VI	SLT9	21		BL-VI		21	13R	BL-VI	SLT13	21		BL-VI	
47		VI-OR		47	ET	VI-OR	EXT.TONE	47	5T	VI-OR	PF	47	10T	VI-OR	PF	47		VI-OR		47	14T	VI-OR	PF	47		VI-OR	
22		OR-VI		22	EC	OR-VI	EXT.CHIME	22	5R	OR-VI	SLT5	22	10R	OR-VI	SLT10	22		OR-VI		22	14R	OR-VI	SLT14	22		OR-VI	
48		VI-GN		48	MOH	VI-GN	MOH	48	6T	VI-GN	PF	48	11T	VI-GN	PF	48		VI-GN		48	15T	VI-GN	PF	48		VI-GN	
23		GN-VI		23	BGM	GN-VI	EXT.BGM	23	6R	GN-VI	SLT6	23	11R	GN-VI	SLT11	23		GN-VI		23	15R	GN-VI	SLT15	23		GN-VI	
49		VI-BR		49	COM	VI-BR	COMMON	49	7T	VI-BR	PF	49	12T	VI-BR	PF	49		VI-BR		49	16T	VI-BR	PF	49		VI-BR	
24		BR-VI		24	PG1	BR-VI	EXT	24	7R	BR-VI	SLT7	24	12R	BR-VI	SLT12	24		BR-VI		24	16R	BR-VI	SLT16	24		BR-VI	
50		VI-SL		50	PG2	VI-SL	ZONE	50	8T	VI-SL	PF	50		VI-SL		50		VI-SL		50		VI-SL		50		VI-SL	
25		SL-VI		25	PG3	SL-VI	PAGE	25	8R	SL-VI	SLT8	25		SL-VI		25		SL-VI		25		SL-VI		25		SL-VI	

## 260 Installing Station Equipment

### 260.1 ET-16-1 and ET-8-2 Installation

ET-16-1 and ET-8-2 are fully-modular electronic key telephone sets. The ET-8-2 keyset comes equipped with a slide switch to assign its CO/PBX line buttons for pickup of CO/PBX lines 1 ~ 8 or lines 9 ~ 16. The ET-8-2 comes assigned to pickup CO/PBX lines 1 ~ 8.

To set the switch:

1. Remove the clear plastic faceplate
2. Remove the wood grain facesheet
3. Locate the slide switch (initially set to "N"). When the switch is set to "N" the ET-8-2 can access lines 1 ~ 8. When the switch is set to "T" the ET-8-2 can access lines 9 ~ 16.

After setting the switch ensure that the assignment of the ET-8-2 in the NPM agrees with the switch condition. NPM assignment determines which 8CO/PBX lines the ET-8-2 is allowed to place on hold. See section 300, Programming, for an explanation of how to make the assignments agree. Each keyset requires 2-pair cabling to the Main Distribution Frame (MDF). The maximum cable length is 1,000 ft. using standard 24 AWG cable and 1,580 ft. using standard 22 AWG cable. Refer to Section 140, "Cabling Requirements", of this manual. For Keyset Connection, see Figures 260-1 and 260-5.

### 260.2 Single Line Telephone Installation

Only DTMF dial single line telephones (Standard 2500 Type) will be able to dial in this system. Each single line telephone requires 1-pair cabling to the Main Distribution Frame (MDF). The maximum cable length is 3,600 ft. using 24 AWG cable, and 5,750 ft. using 22 AWG cable. Refer to Section 140, "Cabling Requirements," of this manual. For Single Line Telephone Connection, see Figures 260-2 and 260-5.

### 260.3 ED-48-1 DSS/BLF and EB-48-1 BLF Installation

The ED-48-1 DSS/BLF is a Modular Electronic Direct Station Selection/Busy Lamp Field Console. The EB-48-1 BLF Unit is a Modular Electronic Busy Lamp Field. Each unit is provided with a 6V DC 1.5A power supply for LED illumination. The power supply is to be plugged into a standard 117V AC outlet. For Data Transmission each Console requires 1-pair cabling to the Main Distribution Frame (MDF).

The maximum cable length is 1,000 ft. using standard 24 AWG cable and 1,580 ft. using standard 22 AWG cable. Refer to Section 140, "Cabling Requirements", of this manual.

For DSS/BLF and BLF Connection, see Figure 260-3 and 260-4 and Table 260-1.

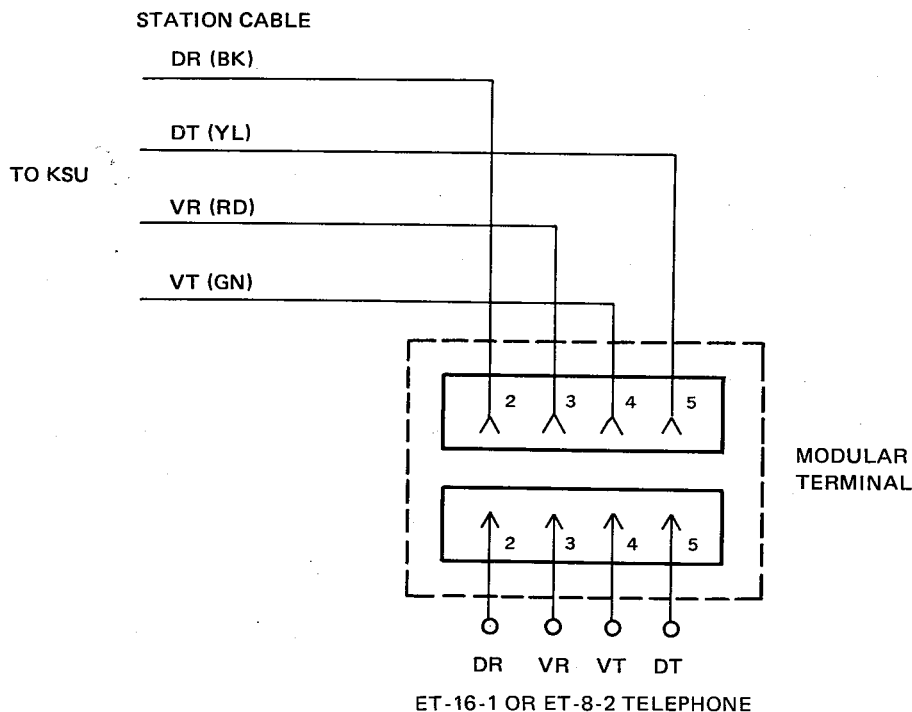
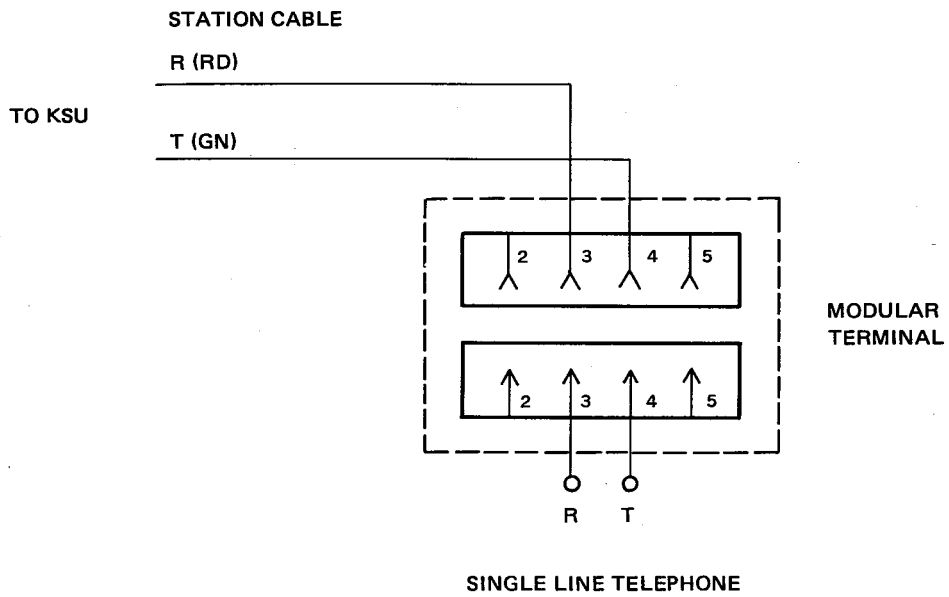
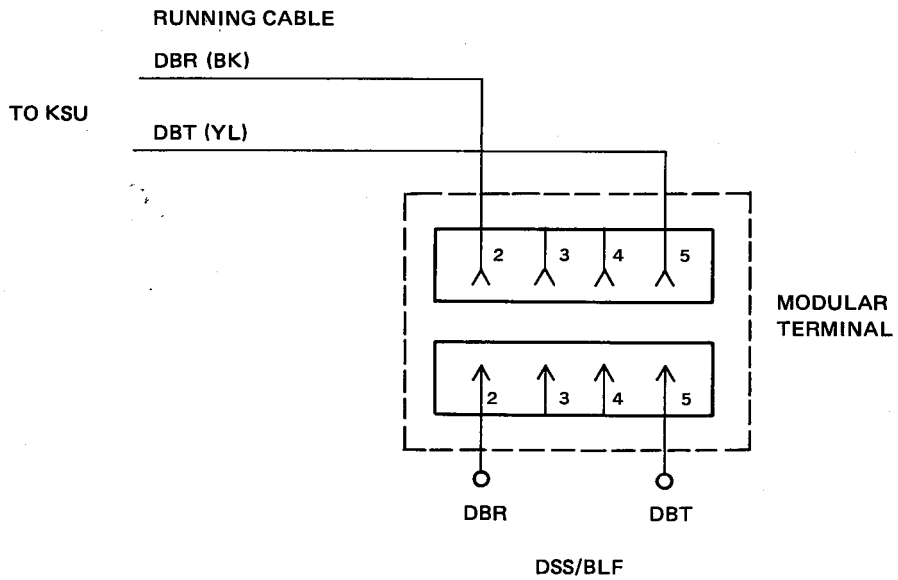

Fig. 260-1 Simplified Schematic — Keyset Connection



**Fig. 260-2 Simplified Schematic – Single Line Telephone Connection**



**Fig. 260-3 Simplified Schematic – DSS/BLF and BLF Connection**

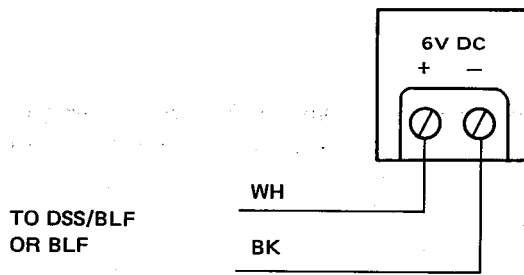

**Fig. 260-4 DSS/BLF and BLF Power Supply Connection**

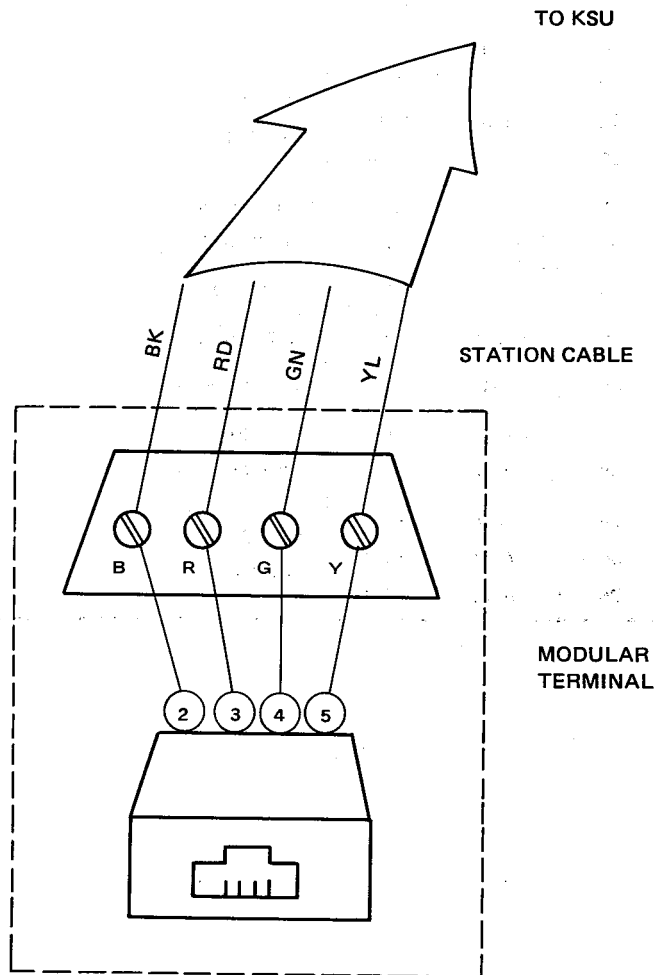

**Fig. 260-5 View of Modular Terminal for Connection of Key Telephone, Single Line Telephone, DSS/BLF, and BLF**



**Table 260-1**

**Optional Feature Connection Information  
J1 Connector and Cable ES-16-( ) KSU**

Pin	Running Cable	Lead Desig.	Circuit Desig.	Circuit	Slot	KSU		
42	YL-OR	1DBT	DSS/BLF1	DS1	DS1	ES-16-( )		
17	OR-YL	1DBR	or BLF1	1				
43	YL-GN	2DBT	DSS/BLF2	DS1	DS1			
18	GN-YL	2DBR	or BLF2	2				
44	YL-BN	EPC1	EXT PAGING CONTROL					
19	BN-YL	EPC2						
45	YL-SL	EPC3						
20	SL-YL	+24						
46	VI-BL	EPI	EXT.PAGING					
21	BL-VL	G	AMP OUT					
47	VI-OR	ET	EXT.RING					
22	OR-VI	EC	EXT.CHIME					
48	VI-GN	MOH	EXT.MOH					
23	GN-VI	BGM	EXT. BGM					
49	VI-BN	COM	COMMON					
24	BN-VI	PG1	EXT ZONE PAGING					
50	VI-SI	PG2						
25	SI-VI	PG3						

## 270 Installing Options

### 270.1 Connection of Music on Hold

Provision has been made to allow connection of a locally-provided external music source to provide Music-On-Hold for held CO/PBX calls. Connection of the Music Source is made at the J1 Block of the Main Distribution Frame (MDF). The output signal level should be approximately 1 milliwatt with 600 ohms impedance. See Figure 270-2 and Table 260-1 for connection information to MDF.

### 270.2 Connection of External Tone Ringer

The external tone ringer will provide common audible on all incoming CO/PBX calls. This feature requires the use of a locally supplied external amplifier and speakers. The amplifier should be mounted away from the KSU and MDF to limit the possibility of inductance. The input power is -15dBV with a high input impedance of more than 1K ohms. See Figures 270-2 and 270-3 and Table 260-1 for connection information to MDF.

### 270.3 Installation of External Zone Paging

When an EP-N KTU is installed in the ES-16-1 KSU, 3-zone External Paging with meet-me answer can be provided. The EP-N KTU contains a 3-watt amplifier and a control circuit for 3-zone selection of External Paging (when a 3-watt amplifier is insufficient, see Connection of High Power Amplifier in Section 270.6). The external speaker(s) should be locally-supplied in correspondence to the output impedance of 600 ohms. The Volume Control (VR1), located on the EP-N, provides a way to increase or decrease the output signal of the amplifier to the speakers. To adjust output signal, turn VR1 clockwise to increase signal, and counter-clockwise to lower signal. An LED is provided to indicate when a zone is being paged.

When an External Page is answered (meet-me answer) the EP-N is released to allow access for another page. See Figure 270-2 and Table 260-1 for connection information to MDF.

### 270.4 Connection of External Background Music

When an EP-N KTU is installed, an external locally-provided music source can be used to supply background music over the External Paging System. The recommended output of the Music Source is 3 watts with 600 ohms impedance. Connection is made on the J1 Block

of the MDF. When a zone is used for paging, background music is cut off only in the zone that was paged. See Figure 270-2 and Table 260-1 for connection information to MDF.

### 270.5 Connection of External Night Chime Control

When an EP-N KTU is installed. Night Chime Service may be provided by controlling locally-provided chime equipment. For this purpose a relay contact is prepared on the EP-N KTU, which provides an uninterrupted closure. The Night Chime is enabled at the attendant position, either by depressing the Night Transfer (NT) key on the DSS/BLF or by manually dialing the Night Transfer access code (48) on the intercom from the attendant(s) keyset. See Figures 270.2 and 270.4 and Table 260-1 for connection information to MDF.

### 270.6 Connection of High Power Amplifier

The EP-N KTU contains a 3-watt amplifier and control circuit for 3-zone Paging. For applications where 3-watts is insufficient, an external high power amplifier may be used. Provision has been made to allow connection of a locally-provided amplifier and three switching relays to the MDF for this purpose. With an external amplifier, only one zone of paging and no background music, the EP-N KTU is not required.

For applications with more than one zone of paging or background music, the EP-N is required to provide control of the external relays (not supplied) for external switching. To provide this option the SW1 switch on the EP-N should be set to the "B" position to remove the 3-watt amplifier from the input to the external amplifier. See Figure 270-1 below. The external switching relays can also be used to control a background music source. See Figures 270-2 and 270-5 and Table 260-1 for connection information to MDF.

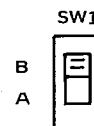
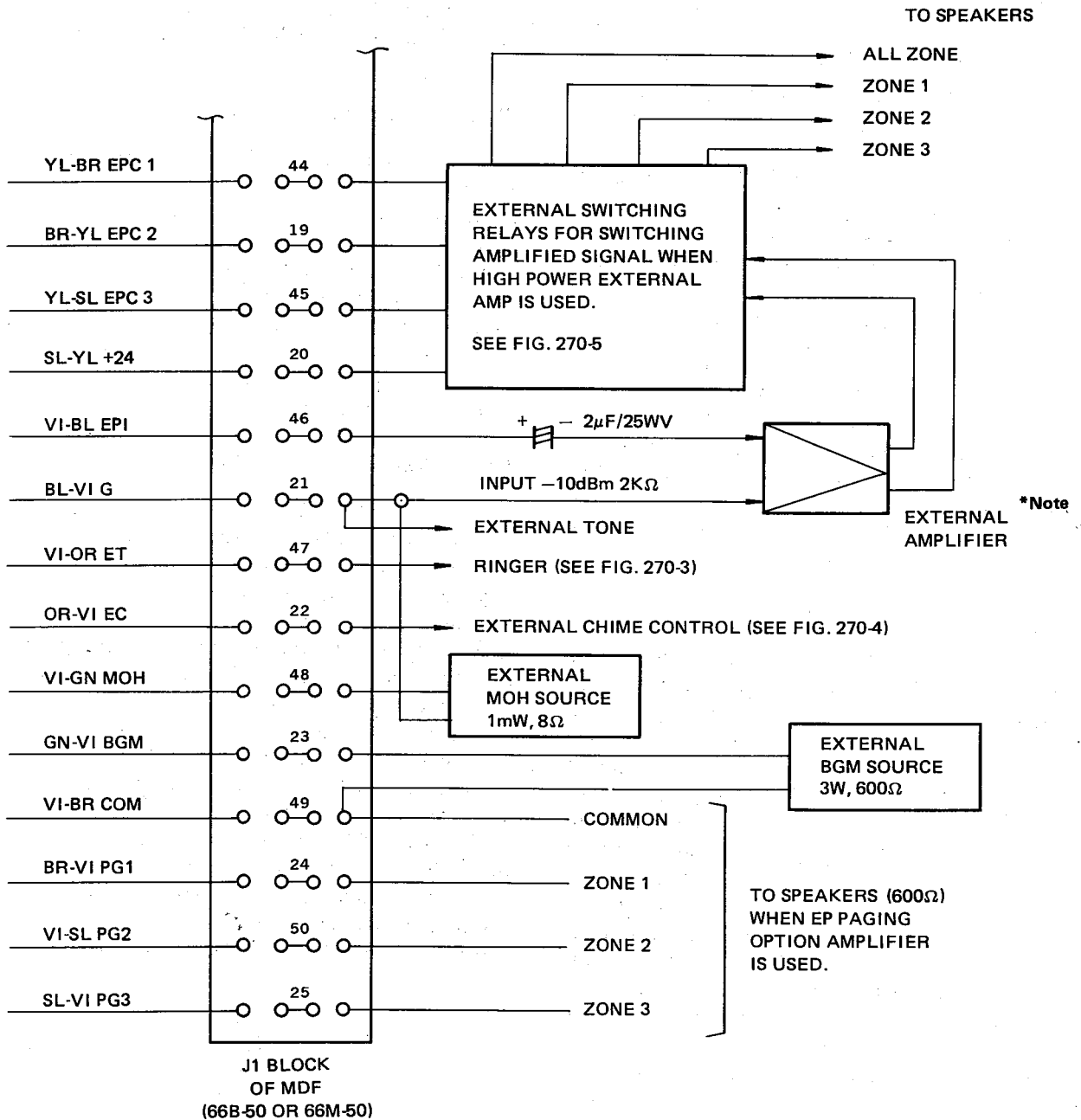
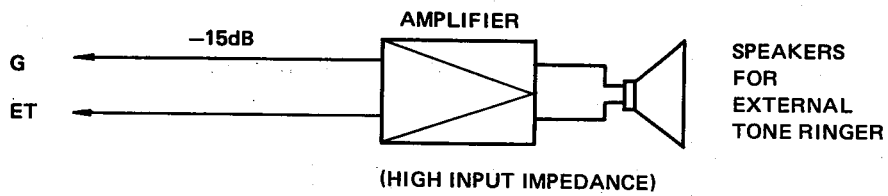

Fig. 270-1 EP-N Switch



**Note:** When an External High Power Amplifier is used, move the SW1 switch on the EP-N KTU to the "B" position. This takes the 3 watt EP-N Amplifier out of service.

**Fig. 270-2 Connection of Optional Features**



**Fig. 270-3 Connection of External Tone Ringer**

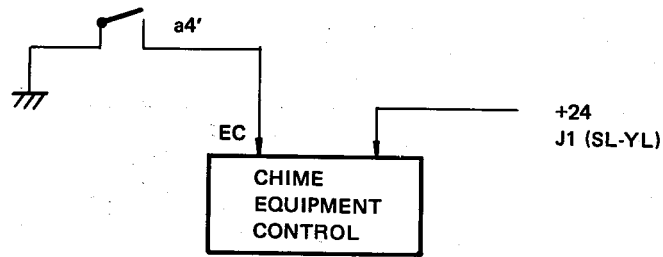

**Fig. 270-4 Connection of External Night Chime Control**

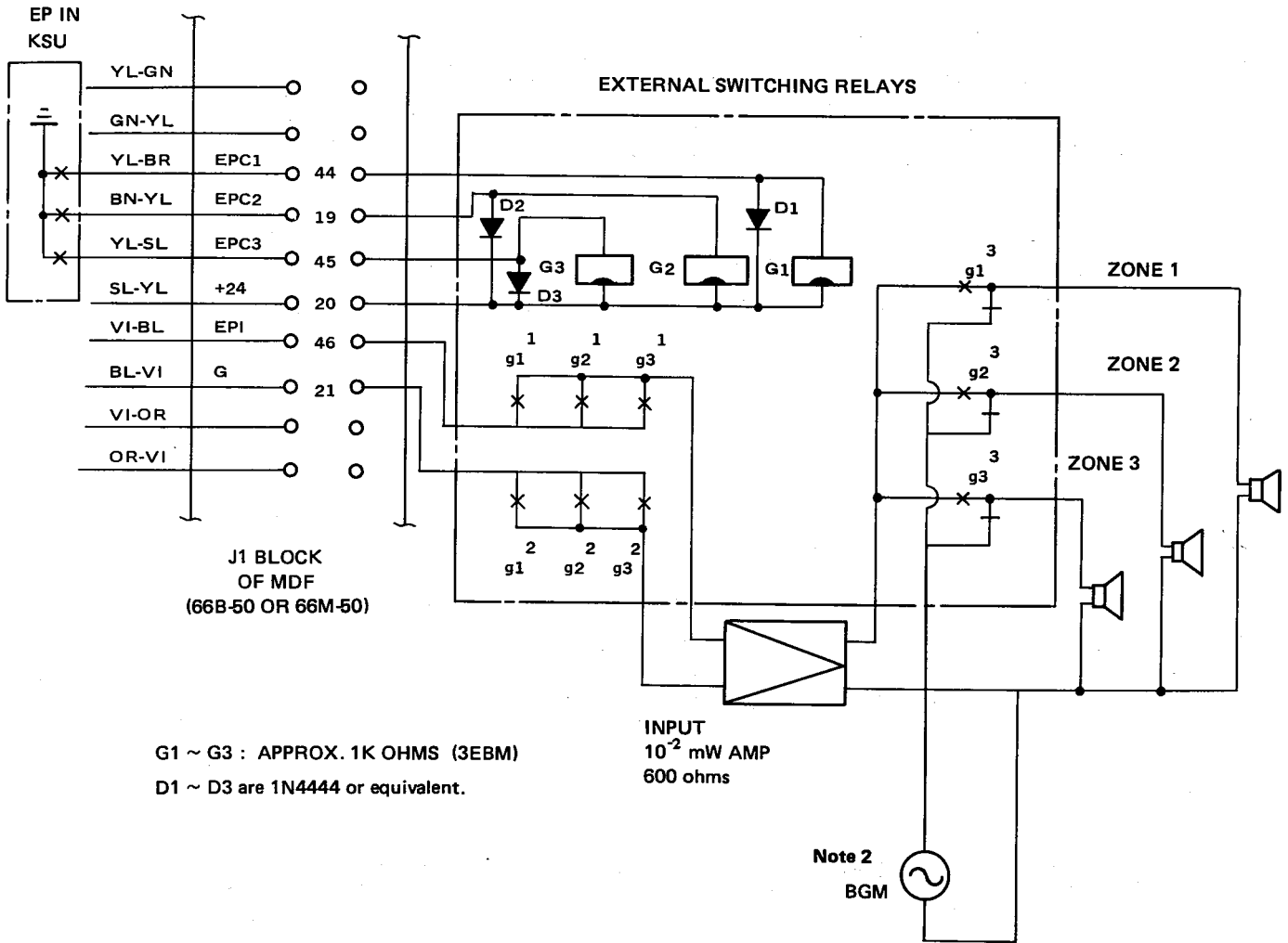

G1 ~ G3 : APPROX. 1K OHMS (3EBM)

D1 ~ D3 are 1N4444 or equivalent.

**Note 1:** When an External High Power Amplifier is used, move the SW1 switch on the EP-N KTU to the "B" position. This removes the 3 watt EP-N amplifier from service.

**Note 2:** When an External Amplifier is used, the BGM source, (if required), is connected as above. The output power and impedance of the BGM source are equal to those of the External Amplifier.

**Fig. 270-5 Connection of External High Power Amplifier**

## 270.7 Connection of Power Failure Telephones

Power failure telephones can always be connected but the method of connection and the requirement for additional single line telephone sets depend on the system configuration.

If the KTUs installed in KSI/SLI 2, KSI/SLI 3, KSI/SLI 5 and KSI/SLI 9 are KSI-N KTUs, additional single line telephones must be provided and connected at the MDF to the leads designated PF SLT 1 ~ PF SLT 16.

If the KTUs installed in KSI/SLI 2, KSI/SLI 3, KSI/SLI 5 and KSI/SLI 9 are SLI-N KTUs, the additional single line telephone sets are not required. The single line sets work as telephone sets in the system when it is powered and as power failure telephone sets when it is not powered. These single line telephone sets are connected at the MDF to the leads designated PF SLT 1 ~ PF SLT 16. A mixture of KSI-N KTUs and SLI-N KTUs can be installed in these slots and MDF connections be made accordingly.

Table 270-1 provides information on connecting single line telephones when power failure KTUs are installed and SLI-N KTUs are in one or more of these 4 slots.

When single line sets are installed to function with both power on and power off, a switch (SW1 ~ SW4) for each of these single line sets must be set to the "P" position. The number of the switch corresponds to the position on the SLI-N to which the single line set is connected.

When the power failure option is not installed, these switches should be set to the "N" position and the single line sets be connected normally.

Since the single line sets are provided with DTMF dials, the CO/PBX lines must allow tone dialing if dialing during power failure is desired. Refer to Figure 270-6 and Table 270-1.

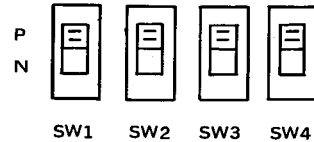

Fig. 270-6 SLI-N KTU Power Failure Switches

Table 270-1 Power Failure Connection

KSI/SLI Slot	Position	Station Number	MDF Desig.	CO/PBX Desig.	Connector	Pair Colors
2	1	105	PF SLT 1	1	J2	YL-GN
	2	106	PF SLT 2	2	J2	YL-BR
	3	107	PF SLT 3	3	J2	YL-SL
	4	108	PF SLT 4	4	J2	VI-BL
3	1	109	PF SLT 5	5	J2	VI-OR
	2	110	PF SLT 6	6	J2	VI-GN
	3	111	PF SLT 7	7	J2	VI-BR
	4	112	PF SLT 8	8	J2	VI-SL
5	1	117	PF SLT 9	9	J3	VI-BL
	2	118	PF SLT10	10	J3	VI-OR
	3	119	PF SLT11	11	J3	VI-GN
	4	120	PF SLT12	12	J3	VI-BR
9	1	133	PF SLT13	13	J5	VI-BL
	2	134	PF SLT14	14	J5	VI-OR
	3	135	PF SLT15	15	J5	VI-GN
	4	136	PF SLT16	16	J5	VI-BR

**270.8 Connection of Station Message Detail Service (SMDS) See Fig. 240-7**

1. Before inserting the SMDS-N KTU into the ES-16-( ) KSU, turn SW 5 to the "on" position to provide battery retention of time/date clock and RAM memory during power outages. Set the DIP switch assembly to the baud rate required to match the printer or other peripheral device to receive the SMDS-N output (150, 300, 600, 1200 and 2400 are the available baud rates).
2. With power off, connect the TA flat cable to the male connector mounted on the TNG-NA KTU and secure it using the latches provided on the male connector.
3. Connect the end of the TB flat cable from the SMDS-N KTU which ends with the RS-232C connector, to the SMDS Output Connector Attachment found in the KTU's box. Use screws provided so that the ribbon cable RS-232C will be pointing up after the SMDS Output Connector Attachment is secured to the KSU. Remove the two screws which hold the P1 connector on the right inner wall of the ES-16-( ) KSU and re-install them so they secure both the P1 connector and the SMDS Output Connector Attachment. The connector is located toward the front of the ES-16-( ) KSU and is pointing upward. Plug the printer cable's RS-232C connector into that from the SMDS-N KTU and secure using the screws provided with the printer cable.
4. After turning power back on adjust time/date clock using switches SW 3 and SW 4.
  - SW 4 is used to display hour and minute or month and date. It also allows changing one of these items, which one changes with each subsequent depression SW 4. The setting which can be changed flashes on the display.

- 1st depression allows setting the minute
- 2nd depression allows setting the hour
- 3rd depression allows setting the day
- 4th depression allows setting the month

**Note:** *That the clock is a 12 hour clock and that a dot on the upper left of display (AM) or upper right of display (PM) shows which 12 hour cycle is current.*

- SW 3 is used to increase the setting which is currently flashing on the display.
- The display will go off if there is no activity of the SMDS-N switches for 3 minutes.

**Note:** *While the SMDS-N KTU can be installed in older ES-16-1 KSUs, it can be installed only under the following conditions:*

1. *The CP-N is removed and a CP-NA is installed.*
2. *The TNG-N is removed and a TNG-NA is installed.*
3. *The RAM-N is removed: the CP-NA has expanded memory redundant. The Electra-16/48 system will not work with a CP-NA and a RAM-N installed.*

5. With power off, insert the SMDS-N KTU into it designated slot which is in the lower shelf of the ES-16-( ) KSU between the PFT-NA KTU and the KSI/SLI 1 slot.

**280 KTU Switch Assignment**

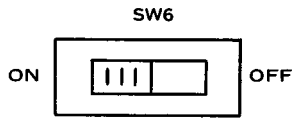

CP-NA Switch for Volatile Memory

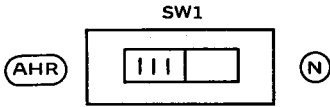

COI-N Automatic Hold Release Switch

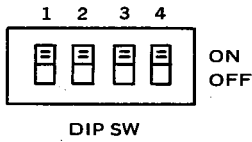

SLI-N DIP Switch for Single Line Telephone Connection

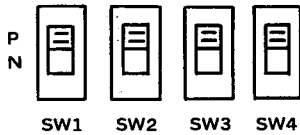

SLI-N Power Failure Switches

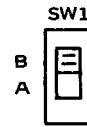

EP-N Switch to Remove the 3-watt Amplifier from the Input of the External Amplifier.

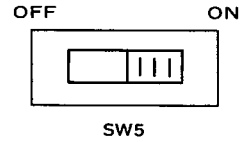

SMDS-N Switch for clock and volatile Memory.

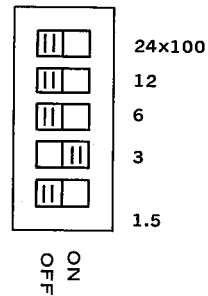

SMDS-N Switch for Baud Rate of Output.



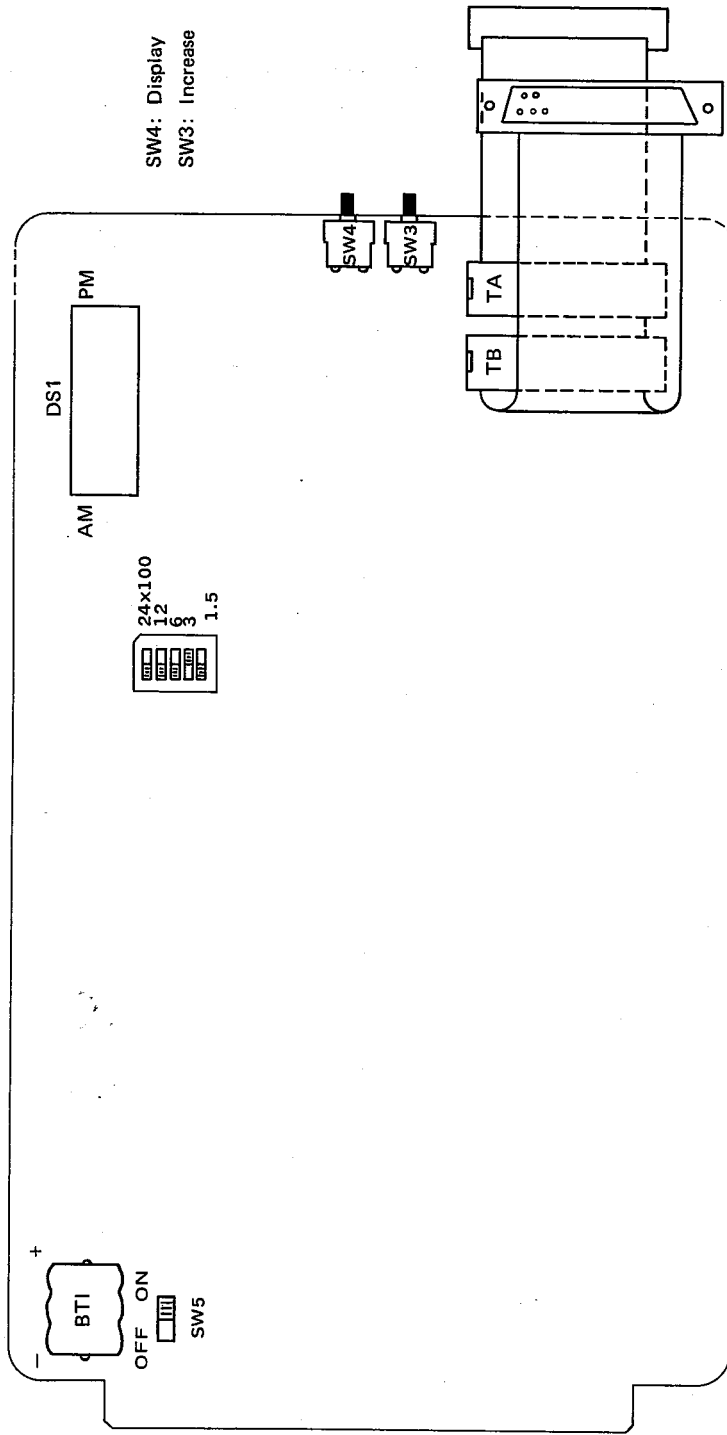

SW4: Display  
 SW3: Increase

Fig. 270-7 Installing SMDS-N KTU

## 310 Explanation of Programming

1. The ELECTRA-16/48 Electronic Key Telephone System comes provided with a Resident System Program in PROM (Programmable Read Only Memory). When the system is powered this Resident System Program is duplicated in RAM (Random Access Memory) and becomes the Network Plan Memory (NPM). The NPM is the program the system actually utilizes. This NPM will normally be supplemented by programming performed at each installation to provide the system program desired for the individual site. The additional programming is entered into RAM which is volatile.

**Note:** Before programming ensure that the "back-up" battery provided on the CP-NA KTU is switched "on" or the additional programming will be lost with the first loss of power to the KSU.

2. Programming is performed from keysets installed as station 101 and station 102. These stations are designated "Attendant" stations and at least one must be installed. Programming is accomplished through manipulation of the various keys (buttons) and the push-button dial pad as explained below:

The programming procedure includes the following steps:

1. Completion of job specification
2. Completion of programming work sheets
3. Taking the attendant keyset "off-line"
4. Selecting a memory block (using DSS buttons) thus selecting the general area of the memory to be modified.
5. Selecting addresses via the dial pad
6. Entering data via the CO/PBX buttons 1 ~ 8
7. Displaying data, clearing data, changing address (plus or minus 1 address increment) and writing data using the ADD-ON, HOLD, ICM, and DO NOT DISTURB buttons.
8. Repeating steps 4 thru 7 until all desired data has been written into memory.
9. Returning the attendant keyset to "on-line" mode.
10. Putting the program into the working Network Plan Memory. This function will occur automatically when the entire system is idle. An alternate method is to depress the reset button on the CP-NA KTU: this will interrupt service. Testing of the new programming can then be performed.

The contents of the Resident System Program (default values) are given below in the following Table 310-1.

**Table 310.1 Resident System Program Contents**

Function	Default Value
Prime Line	Not Assigned
Station Class Assignment	All stations are Class 0 (non-restricted)
CO/PBX Group Assignment	All lines are Class A (dial access 9)
Line Assignment	All lines are CO
Hold Recall Assignment	Time is 60 sec.
Paging Timeout Assignment	Time is 90 sec.
Camp-on Recall Timing Assignment	Time is 60 sec.
MFR Timing Assignment	Time is 10 sec.
Hook-Flash Timing Assignment	Time is 0.4 sec.
#/* First Digit Assignment	#/* cannot be sent as 1st digit
Prime Line on Incoming Calls	No prime line on incoming
Attendant Exclusive ICM Line Assignment	No exclusive ICM
CO/PBX Assignment for SLT	All line classes are CO
Day Mode CO/PBX Ringing Assignment	All lines ring at 101 and 102
Night Mode CO/PBX Ringing Assignment	101 ~ 116 will ring
Internal Paging Zone Assignment	No keysets in any zone
Call Pickup Zone Assignment	No station in any zone
Station Attendant Assignment	All stations-attendant 101
Telephone Type Assignment	All SLTs work, all keysets 16 button sets
CO/PBX Line Scan Assignment	Scan goes from button 1 to 16
Speed Dial Toll Override	Toll restriction is not overridden
PBX Access Code Assignment	No PBX access code assigned
Digit Rejection Assignment	No digits rejected
"1" + Dialing Assignment	"1" + dialing
Toll Restriction Override Table Assignment	800 is only 3-digit code allowed
Off Hook Ringing Assignment	No Keysets ring off-hook
DSS Installation Data	Both DSS/BLFs are installed
Attendant Automatic Answer	Neither attendant has ringing line preference
System Refresh Basis	Based on no change in status
Incoming Restriction	No station is restricted
Speed Dial Excess Assignment	No station speed dial memory reassigned
"Attendant Overflow	Dial 0, no overflow to other attendant
"SMDS Output Timer	Time is 15 sec.
"SMDS Incoming Call Report	Incoming calls are reported

## 320 Programming Operations (See Table 320.1)

### 320.1 Going Off-line

1. At attendant keyset (station 101 or station 102) perform the following:
  - depress ICM button
  - depress ON/OFF button or lift handset
  - receive dial tone
  - dial #, \*, 0

The attendant keyset is then “off-line.” If no activity is performed at the keyset for 3 minutes, the keyset will return to “on-line” mode.

### 320.2 Selecting a Memory Block

1. To select a memory block, depress the appropriate DSS button on the attendant keyset while in off line status. Please use the programming overlays to simplify button selection.

**Note:** *Taking the attendant keyset off-line removes that keyset from service. The rest of the 16/48 system will continue to work. In some cases it may be desirable to enter night mode to provide for ringing while the attendant keyset is off-line. This will depend on the installation.*

2. Memory Block 20 is used to initialize all system NPM memories at once when desired. Use of this memory block will return the system to the resident program.
3. Selection of a memory block is confirmed by the block number followed by a horizontal line being displayed on the attendant keyset's 2-digit display. Memory Block 20 is displayed with two horizontal lines.

### 320.3 Selecting Addresses Using the Dial Pad

1. After selecting the memory block, the first address desired must be entered by using the dial pad. After dialing 1 or 2 digits (dialing a 0 first is not required for addresses numbering less than 10) the display will show the address selected. If programming deals with consecutive addresses there is no need to redial as addresses are automatically increased by 1 after writing data into memory. Manual operation of function buttons also allows increasing or decreasing the address by increments of 1. Redialing to change an address is possible at any time.

### 320.4 Entering Data Using CO/PBX Buttons

1. To enter data the top row of CO/PBX buttons is used (for the ET-8-2 this is the only row of CO/PBX buttons). The LED incorporated in the CO/PBX button shows the status of the datum corresponding to that button. When an address is in “clear” mode no LED is lit.
2. The method of entry using the CO/PBX buttons can vary from address to address. Sometimes they are used singly as for a YES/NO choice, sometimes in groups to write numbers in binary. The programming sheets for the different features shows how to enter data for each individual address under consideration.

### 320.5 Use of Function Buttons in Programming

1. The Do Not Disturb (DND) button is used to perform a clear. Once a CO/PBX button is depressed and the LED is lit again depressing the CO/PBX button will change this status: the Do Not Disturb will clear the entire address (up to 8 CO/PBX buttons) which can then be reprogrammed. The Do Not Disturb button will only clear that single address except when in Memory Block 20.
2. The HOLD or ADD-ON button depressed once after dialing an address will cause the contents of that address to be displayed: immediately after dialing an address one of these buttons must be depressed. Each subsequent depression of the HOLD button will decrease the address by 1 and display the contents of that new address. Each subsequent depression of the ADD-ON button will increase the address by 1 and display the contents of that new address. Only the first use of either button after dialing an address will display that address without changing it.
3. The ICM button is used to write the contents of the address as it is currently displayed into the programming RAM: all previous operations will not result in any program change until this step is completed. The only time more than 1 address is written at one time is in Memory Block 20. In this memory block all addresses can be cleared and written to initialize the RAM memories and return the system to the resident program.

4. Memory Block 20 can be used to initialize all additional system programs in RAM memories: Mode 20 does not affect the resident system (in PROM). In this memory block a single depression of the Do Not Disturb button clears all addresses except those affected by the PROM. (Resident System Program)

### 320.6 Going On-line

1. Restore the handset (depress ON/OFF button) to return the attendant keyset to on-line mode. The attendant keyset display will show 00 until program is accepted into the working NPM memory. Other displays will temporarily override this display, but it will return until the system working program changes.

### 320.7 Resetting System to Change Contents of NPM

1. It is possible to reset the system by depressing the momentary button on the CP-NA KTU. This may not be necessary because the system memory will be re-written when the entire system is idle. While this may cause delay it will not drop all service in progress as the reset will.

**Table 320.1 List of Programming Operations**

#### TO GO OFF-LINE

- lift handset or depress ON/OFF button
- depress ICM
- dial #, \*, 0

#### TO SELECT MEMORY BLOCK

- depress DSS button for desired block

#### TO SELECT ADDRESS

- dial 1 or 2 digit number
- depress ADD ON button to see address contents

#### TO INCREASE 1 ADDRESS (+ ONE ADDR)

- depress ADD ON button

#### TO DECREASE 1 ADDRESS (- ONE ADDR)

- depress HOLD button

#### TO CLEAR AN ADDRESS

- depress DND button

#### TO WRITE AN ADDRESS

- depress ICM button

#### TO GO ON-LINE

- restore handset or depress ON/OFF button

## 330 Job Specification

### 330.1 Instructions for Completing Job Specification

1. The first page contains items A ~ C and 1 ~ 5. These have been provided as a convenience and do not affect programming.
2. Item 6 is CO/PBX Assignments. Much of this table is also provided as a convenience. Two sections, REFERENCE NUMBER and PROGRAMMING DATA, are used in programming.
  - A) REFERENCE NUMBER is the number the CO/PBX line will be referred to in programming material.
  - B) PBX LINE refers to the origin of the line connected; Is it from a PBX or from a Central Office? This will affect speed dialing, last CO/PBX number redial and restriction features.
  - C) LINE GROUP (A, B, C, or NOT INSTALLED). Every CO/PBX line installed must be assigned a line group, even if all lines are in the same group. At the time of installation all CO/PBX lines will be in Group A as is provided by the resident system program. Every installed CO/PBX line circuit which does not receive a CO/PBX line must be assigned as NOT INSTALLED. This assignment affects single line access to desired type of line (access code for group A is 9, access code for group B is 8, access code for group C is 7). This assignment also affects the restriction feature. Programming CO/PBX line circuits as NOT ASSIGNED prevents access to unterminated circuits.
3. Item 7 is Station Assignments. Some of this table is provided as a convenience. Two sections, REFERENCE NUMBER and PROGRAMMING DATA, are used in programming.
  - A) REFERENCE NUMBER is the station intercom number and is the number the station will be referred to in programming material.
  - B) CO/PBX RING ASSIGNMENT provides space to record requirements for both types of ring assignment: day and night mode. When a telephone is to ring for a line in day mode only, enter a "D". When a telephone is to ring for a line in night mode, enter a "N". These two ringing assignments are independent and are completely flexible in the case of assigning keysets: the power supplied by the RSG-N ring supply unit limits the number of single lines ringing at the same time to approximately 12 telephones.
  - C) RESTRICTION CLASS and CODE. Only the class is required for programming. Each CLASS has a unique CODE, and adding the code will make understanding the restriction easier. See the table located on the Station Class Assignment Table in Section 340 Programming Work Sheets.
  - D) CALL PICKUP GROUP. This assignment enables stations to "pick-up" calls to telephones within their group: no telephone can be in more than one group.
  - E) OFF HOOK RINGING. On a station basis, keysets can be programmed to receive CO/PBX incoming ring signal when they are "receiver off-hook". Off-hook ringing follows the keyset ringing assignment.
  - F) PRIME LINE. This is a discriminatory feature. This assigns a "prime line" which will be seized by a keyset going "off hook" without depressing any CO/PBX buttons. This feature will only operate when the "prime line" is in idle status unless a programming choice is exercised: Then the line will be seized when ringing or idle.
  - G) INTERNAL ZONE. This assignment is discriminatory and can be applied only to keysets in an "internal zone" paging group: activation of this feature enables paging over multiple keyset speakers at one time. Any number of keysets can be in a zone, no keyset can be in more than one zone. All keysets remain in the "All Call" group.
  - H) STATION ATTENDANT provides a "primary" attendant (101 or 102) on a station basis. The attendant selected will be the first one reached by dialing "0" on the intercom. If the primary attendant is busy, the call will overflow to the secondary (other) attendant.

I) **INCOMING RESTRICTION** can be provided on a trunk per station basis. This type of restriction prevents a station from seizing a trunk when it is ringing or when it has been placed on hold by anyone other than an attendant. Attendant transfer is not affected by this feature.

J) **EXCESS SPEED DIAL ASSIGNMENT** is used to assign the Speed Dial – Station memory of station not installed to keysets which are installed; thus allowing the keysets up to 20 Speed Dial – Station memories.

Please note only excess speed dial memories can be assigned. Once a station is installed the associated memory will revert to the station.

K) **ATTENDANT OPTIONS** apply only to keysets 101 and 102. Please refer to Section 340.1, "Programming Details" for an explanation of these options.

4. **Item 8 is System Assignments.** These assignments apply systemwide and include time-outs, miscellaneous parameters and Toll Restriction Override Code and format assignment.

A) **TIME-OUTS** are listed with durations in seconds. The rightmost time-out for external paging time means infinite time: There is no time-out in this case. The desired time-out can be circled.

B) **MISCELLANEOUS** is a group of odd parameters. For a description of what these assignments do, please refer to Section 340.1, "Programming Details", for an explanation of what is the results of allowing or disallowing in each case.

C) **TOLL RESTRICTION** is only used when there are toll restricted stations in a system. Please refer to Section 340.1, "Programming Details", for an explanation of these parameters.

SITE	A	B	C
Name: _____	Supervisor: _____	By: _____	
Address: _____	Cutover Date: _____	Number: _____	
	Ref. No. : _____		
	Additional: _____		
Tel. No. : _____			
Contact: _____			
Ref. No. : _____			

**1. System Size:**

- ES-16-2
- ES-48/32-1
- ES-48/32-1
- \_\_\_\_\_ Number of CO/PBX Lines
- \_\_\_\_\_ Number of Keysets
- \_\_\_\_\_ Number of Single Line Sets
- \_\_\_\_\_ Number of DSS/BLFs
- \_\_\_\_\_ Number of BLFs

**2. KTU options installed:**

- AHR-N
- EP-N
- PFT-A
- PFT-B
- SMDS-N

**3. External equipment installed:**

---

---

---

---

---

---

---

---

---

---

**4. Comments:**

---

---

---

---

---

---

---

---

---

---

**5. Use as Desired.**









### 8. INCOMING RESTRICTION ASSIGNMENT

STA.	CO/PBX LINES																STA.	CO/PBX LINES															
	1	2	3	4	5	6	7	8	9	10	11	12	13	14	15	16		1	2	3	4	5	6	7	8	9	10	11	12	13	14	15	16
1																	25																
2																	26																
3																	27																
4																	28																
5																	29																
6																	30																
7																	31																
8																	32																
9																	33																
10																	34																
11																	35																
12																	36																
13																	37																
14																	38																
15																	39																
16																	40																
17																	41																
18																	42																
19																	43																
20																	44																
21																	45																
22																	46																
23																	47																
24																	48																

### EXCESS SPD ASSIGN

STA. SPD MEMORY			
STA.	RCVD	STA.	RCVD
1		25	
2		26	
3		27	
4		28	
5		29	
6		30	
7		31	
8		32	
9		33	
10		34	
11		35	
12		36	
13		37	
14		38	
15		39	
16		40	
17		41	
18		42	
19		43	
20		44	
21		45	
22		46	
23		47	
24		48	

### Attendant Options

Ringing Preference

STA.	ALLOW	DISALLOW
101		
102		

DSS/BLF Installed

STA.	Y	N
101		
102		

## 9. SYSTEM ASSIGNMENTS

### TIMEOUTS

### DURATION IN SECONDS

HOLD RECALL TIME	30	60	120	240		
EXTERNAL PAGING TIME	90	120				
CAMP-ON RECALL TIME	30	60	120	240		
MFR-N TIMEOUT	10	15	20	25	30	35
RECALL BUTTON TIMING	0.4	1.0	1.5			
CALL FORWARD – NO ANS	15	30	45			
SMDS OUTPUT TIMER	0	15	30			

### MISCELLANEOUS

	ALLOW	DISALLOW
# * ON FIRST DIGIT		
PRIME LINE FOR INCOMING CALLS		
ATT. EXCLUSIVE ICM PATH		
PBX ASSIGN FOR SLT ACCESS		
SPEED DIAL TOLL OVERRIDE		
ATTENDANT OVERFLOW		
SMDS INCOMING CALL REPORT		
ATTENDANT AUTOMATIC ANSWER		

CO/PBX LINE SCAN #	
--------------------	--

	NO CHANGE	IDLE
SYSTEM REFRESH BASIS		

### TOLL RESTRICTION ENTER NUMBERS DESIRED

PBX ACCESS CODE							
REJECTION CODES							
OVERVERRIDE TABLE							

1 + DIALING	ALLOW	
	DISALLOW	

## 340 Programming Sheets

### 340.1 Programming Details

#### 1. Programming Work Sheets

The following programming work sheets, along with the programming overlays are intended to ease programming. The programming work sheets, if kept up to date with respect to program changes, can also be used as a record of existing installation.

In the following pages the words "default value" will be seen. This is the value which has been programmed in the resident system program and is the value which will remain if you "default" i.e. do not change it.

The following symbols are also seen in the programming work sheets:



LED  
OFF



LED  
ON

#### 340.2 Memory Block 1

##### 1. Prime Line Pickup — (See Fig. 340-1)

This program area is used to allow a keyset to seize a selected CO/PBX line without depressing that line's button. The line will be selected when it is in idle or, on a systemwide basis, the line can be selected when it is idel or ringing (see Fig. 340-11). More than one keyset can be assigned the same CO/PBX line as its prime line. No keyset can be assigned more than one prime line. Programming a prime line for a single line telephone will not cause misoperation although the feature will not work.

Each keyset has been assigned an address which matches the last two digits of its intercom member. The CO/PBX buttons 1 ~ 5 are used to program in a binary value 0 ~ 16.

The default value is 0 which means no prime line on all stations. The binary values 1 ~ 16 correspond to the desired CO/PBX line buttons on the telephone.

##### 2. Station Class Assignment — (See Fig. 340-2)

This program area is used in assigning restrictions to stations. The programming work sheet has a chart which shows how each class of station 0 ~ 15 is restricted with regard to each of the 3 CO/PBX line groups.

In the chart N, stands for Not Restriction, T for Toll Restricted and O for Outgoing Restricted. The classes range from Not Restricted on all 3 groups, (class 0) through Toll Restricted on all 3 groups (class 7), to Outgoing Restricted on all 3 groups (class 15).

Please note that *not* all possible combinations are to be found. Another important fact which may affect how CO/PBX lines are grouped is that the CO Group assignment also provides the CO/PBX access codes for telephones. CO/PBX lines in Group A are obtained by dialing "9", those in group B by dialing "8", and those in group C by dialing "7". The default value for station class is 0 (Not Restricted on all 3 groups of CO/PBX lines for all stations). Each address from 49 ~ 72 corresponds to two stations. CO/PBX buttons 1 ~ 4 are used for one station and buttons 5 ~ 8 for the other. The station class number is entered in binary format.

##### 3. CO/PBX Group Assignment — (See Fig. 340-3)

This program area is used for two purposes. Assigning a CO/PBX line to group A provides the line with an access code of "9" which is used by single line telephones for dial access and by keysets for station speed dial number programming. The CO/PBX group assignment affects the Toll and Outgoing Restriction assignment as well. The access code for group B is "8" and for group C is "7". Programming a line as "Not Assigned" prevents access to unterminated lines and provides for error tone when the corresponding keyset button is depressed.

The addresses 73 ~ 76 each correspond to 4 CO/PBX lines. Each pair of buttons 1 and 2, 3 and 4, 5 and 6, and 7 and 8 are used to program a CO/PBX line into a group. The default value for CO/PBX group is A for all lines.

##### 4. Line Assignment — (See Fig. 340-4)

This program area assigns lines as either CO lines, or as PBX lines to provide for a pause when stations use speed dial or last number dialed. For proper functioning, especially when Toll Restriction is installed, it is important that PBX lines be assigned as such.

Each of the addresses 77 and 78 correspond to 8 lines. Each button 1 ~ 8 represents a line in each address. The default value for line assignment is CO line.

5. Hold Recall Timing – (See Fig. 340-5)

This area of the programming provides for selecting the length of time before recall of attendant held calls and of exclusively held calls. The time-out on exclusive hold doesn't begin until the telephone handset is returned to the cradle.

Address 79 is used to select the timing. Buttons 1 and 2 are used to select one of the time-outs. The default value for hold recall is 60 seconds.

6. Paging Time-Out – See Fig. 340-6)

This area of the program is used to set the duration of an external page. Possible values are 90 seconds, 120 seconds, or no time-out.

Address 80 is used to select the duration of paging. Buttons 1 and 2 select the time-out value. The default value is 90 seconds.

7. Camp-On Recall – (See Fig. 340-7)

This area of the program is used to select a time-out for recall to a DSS/BLF attendant of calls which were camped-on or transferred by a DSS/BLF attendant. Address 81 is used to select this time-out. Buttons 1 and 2 offer time-outs of 30 seconds, 60 seconds, 120 seconds or 240 seconds. The default value is 60 seconds.

8. MFR Timing – (See Fig. 340-8)

This area of the program selects on a system basis how long a Multi-Frequency Receiver will be connected to a single line set if no digit is dialed. This is important when single line telephones are Toll Restricted: the system time-out should be longer than the CO or PBX time-out.

Address 82 is used to set the time-out. Buttons 1, 2, and 3 offer a selection of 6 time-outs ranging from 10 seconds to 35 seconds. The default value of the time-out is 10 seconds.

9. Hook-Flash Timing – (See Fig. 340-9)

This area of the program allows choice on a system basis of how long the disconnect signal produced by depressing the recall button on the keysets lasts. The recall button can be used for "flashing" when behind a PBX or as a recall button when the system is connected to Central Office lines.

Address 83 is the memory location used to select this time-out. Buttons 1 and 2 offer time-outs of 0.4 seconds, 1.0 seconds, or 1.5 seconds. The default value is 0.4 seconds.

10. # and \* First Digit Restriction – (See Fig. 340-10)

This area of the program can be used to allow # and \* to be dialed as a first digit on CO/PBX lines on a system basis. If this is allowed the following feature access codes change.

System Speed Dial – for Keysets

Last Number Dialed – for Keysets

Address 85 button 1 is used either to allow or disallow these tones to be sent as a first digit. The default value is disallow.

11. Prime Line Pickup for Incoming Calls – (See Fig. 340-11)

This area of the program affects whether CO/PBX lines which are in ringing status are eligible for prime line pickup.

Address 86 button 1 sets the value. The default value is that prime line pickup will not seize ringing lines.

12. Attendant – Exclusive ICM Path – (See Fig. 340-12)

This area of the program allows for assignment of one Intercom path to be dedicated to the attendant(s). This removes the path for origination from the rest of the system. If the attendant ICM path is busy and the other attendant attempts an internal call, the call must compete with any other originators for an ICM path.

Address 91 button 1 is used to assign whether there is an exclusive attendant path. The default value is no attendant exclusive ICM path.

13. CO/PBX Assignment for SLT Access – (See Fig. 340-13)

Where CO/PBX lines are programmed as CO or PBX and where CO/PBX lines are programmed into CO/PBX line groups are two separate locations in Memory Block One. Thus it is possible to mix CO lines and PBX lines in a single CO/PBX line group. To prevent misoperation when this occurs this area of the program allows assignment of whether CO lines or PBX lines in each CO/PBX line group will be accessed by the access code. This also affects keyset users if they program access codes in their station speed dial.

Address 93 is used to assign which type of line will be selected. Buttons 1, 2, and 3 correspond to class C, class B, and class A respectively. The default value is CO line in all 3 cases.

### 340.3 Memory Blocks 2 & 3

#### 1. CO/PBX Incoming Ring Assignment — (See Fig. 340-14, 15)

Memory Blocks 2 and 3 are almost identical except that Memory Block 2 deals with day mode CO/PBX Ringing Assignment and Memory Block 3 with night mode CO/PBX Ringing Assignment. Each memory block has 96 addresses. Each CO/PBX line uses 6 addresses for Ring Assignment. This allows assignment for all CO/PBX lines. Each address uses 8 buttons: each one corresponds to a station. This allows assignment for all 48 stations.

The default value in Memory Block 2 is the attendant telephones ring for all 16 CO/PBX lines. The default value for night mode is stations 101 ~ 116 ring on all CO/PBX lines.

### 340.4 Memory Block 4

#### 1. Internal Paging Zone Assignment — (See Fig. 340-16)

This area of the program is used to assign keysets into internal paging zones. Single line telephones cannot receive a voice page but programming them in a zone will not cause any misoperation. Keysets can be in any of the zones or in no zone. They cannot be assigned to more than one zone.

Addresses 1 ~ 12 are used to assign keysets into zones. The CO/PBX buttons 1 ~ 8 are used in pairs; 1 and 2, 3 and 4, 5 and 6, 7 and 8, with each pair representing a station. The default value is no zone.

#### 2. Call Pick-up Zone Assignment — (See Fig. 340-17)

This area of the program is used to assign stations into call pick-up groups. There are 15 pick-up groups plus a group which can't pick-up calls. There is no limit to the number of stations in a group but no station can be in more than one call pick-up group.

Addresses 13 ~ 36 are used to assign stations into call pick-up zones. Buttons 1 ~ 4 are used to assign one station, button 5 ~ 8 are used for another. The default value is no call pick-up group assigned.

#### 3. Station Attendant Assignment — (See Fig. 340-18)

This area is used to determine which of the two attendants (keyset 101 and keyset 102) is to be the associated attendant for each station. A station dialing

“0” on intercom will be connected to the attendant associated with him unless that attendant is busy. In that case the call will be routed to the other attendant. If both are busy the caller will receive error tone and must abandon the attempt.

Addresses 37 ~ 42 are used to assign station attendant assignments. Each button 1 ~ 8 represents a station assignment of 101 or 102 as that station's attendant. The default value for all stations is 101.

#### 4. Telephone Type Assignment — (See Fig. 340-19)

In this area of the program, the type of each telephone set that is installed is assigned (i.e. ET-16-1, ET-8-2 for CO/PBX lines 1 ~ 8, ET-8-2 for CO/PBX lines 9 ~ 16, or SLT). All 16 CO/PBX buttons will work on an ET-16-1 assigned properly. The 8 CO/PBX buttons on the ET-8-2 telephone set will work as CO/PBX lines 1 ~ 8 or 9 ~ 16 depending on the ET-8-2 switch assignment: this area of the program allows holding as the assigned lines and denies holding of the non-assigned lines. Single line telephone sets should be programmed as such although they do work no matter what assignment they receive: this is part of the Resident System Program which allows immediate use of the system even before programming.

Addresses 43 ~ 54 are used for telephone type assignment. Each address allows assignment of 4 telephones with the button pairs 1 and 2, 3 and 4, 5 and 6, and 7 and 8 each corresponding to a telephone. The default value for telephone type is ET-16-1.

#### 5. CO/PBX Line Scan Assignment — (See Fig. 340-20)

This area of the program is used to select the starting point and direction in which CO/PBX lines will be scanned for idle status in response to a request for a CO/PBX line originated by a single line telephone (using the dial) or a keyset (using station speed dial). The system will scan from button 1 to the right and down, or from a selected button to the left and up. For best efficiency and to avoid so-called “collisions” it is often best to start the CO/PBX line scan from the button with the highest number which has a CO/PBX line installed.

Address 79 is used to assign the start of the CO/PBX line scan. The button number desired is entered using buttons 1 ~ 5 to write the number in binary. The default value for CO/PBX line scan is from button 1 to the right and down.



6. Speed Dial Toll Override – (See Fig. 340-21)

This area of the program is used to permit or deny toll restricted stations using the system speed dial numbers to override the toll restriction. This choice applies to all system speed dial memories and all toll restricted stations on a system wide basis.

Address 80, Button 1 is used to allow or disallow system speed dial toll override. The default value is no speed dial toll override.

### 340.5 Memory Block 5

1. PBX Access Code Assignment – (See Fig. 340-22)

This area of the program is used to allow up to 2 single digit access codes to be dialed without the Toll Restriction Inspection occurring. This allows more flexibility in Toll Restriction when a PBX access code is to be dialed and inspection is not desired.

Two individual digits may be programmed.

Address 1 is used to enter both single digit access codes to be allowed without inspection. The buttons 1 ~ 4 and 5 ~ 8 are used to write both numbers in binary from 1 ~ 10 (10 is equivalent to 0 on the dial pad). The default value is no PBX access code assigned.

2. Rejection Code Assignment – (See Fig. 340-23)

This area of the program is used to prevent repeated dialing of the same digit from the beginning of the dialing process to defeat the Toll Restriction Inspection Process. This ability has been entered into the program so that when an exchange “ignores” a particular digit or digits, if they are the first digits dialed and merely continues to offer dial tone, the Toll Inspection Process will still be valid. Up to 4 separate digits can be entered.

Addresses 2 ~ 3 are used to enter the digits. Buttons 1 ~ 4 and 5 ~ 6 will each contain one digit in each address. The digits are written into memory in binary format using 1 ~ 10 with a binary 10 equaling 0 on the dial pad. The default value is no digits rejected.

3. 1 + Dialing Assignment – (See Fig. 340-24)

This area of the program is used to select a Toll Restriction format to suit the Installation Site Requirements.

In some locations it is necessary to dial a “1” before dialing a foreign area code and local exchanges have 3-digit office codes with the same format as area codes. If 1 + Dialing is entered into the program, calls beginning with 1 (calls to foreign area codes) will be denied

but local (for instance to a local exchange 408) will be allowed. In other locations it is not necessary to dial a “1” before dialing a foreign area code: in this case 1 + Dialing should not be entered into the program.

Address 4, button 1, is used to select which type of Inspection process is desired. The default value is 1 + Dialing is entered.

4. Toll Restriction Override Table – (See Fig. 340-25, 26)

This area of the program can be used to enter up to 30 3-digit codes to override the Toll Restriction. Some uses for this table would be to provide access to common service codes such as 911, 611 and 411 and to allow dialing 800 numbers and selected foreign area codes. Addresses 5 ~ 64 are used to enter the 3-digit codes. Two addresses are used for each code. The first four buttons of an odd-numbered address are used to enter the first digit. The second four buttons are used to enter the second digit. The first four buttons of the following even-numbered address are used to enter the third digit. The numbers are entered in binary with 10 equal to 0 on the dial pad. Any address which is completely blank (no LEDs lit) is recognized as terminating the Override Table so no address can be skipped. The default value of the Override Table is 800.

5. Off Hook Ringing Assignment – (See Fig. 340-27)

This program area is used to enable keysets, on a per station basis, to receive an audible CO/PBX incoming ring signal (in accordance with their CO/PBX ring assignment) although in “off-hook” mode. Addresses 81 ~ 86 are used to assign off hook ringing: each button 1 ~ 8 of each address corresponds to a station. This allows assignment for up to 48 stations. The default value is no stations have off hook ring.

6. DSS Installation Data – (See Fig. 340-28)

In this area of the program the presence, or absence, of DSS/BLFs is indicated. If a DSS/BLF is indicated as absent the attendant keyset will receive audible hold recall indication from its speaker. If the DSS/BLF is indicated as present the audible hold recall indication will come from its buzzer.

Address 90 is used for assignment with button 1 corresponding to DSS1 and button 2 corresponding to DSS2. The default value is that both DSS/BLFs are indicated as installed.

#### 7. Attendant Automatic Answer – (See Fig. 340-29)

This program area enables the attendant keysets to pick-up CO/PBX incoming calls (for which they are ring assigned) by lifting the handset. No CO/PBX button depression is necessary.

Address 91 ~ 92 are used to program this feature with button 1 of address 91 corresponding to keyset 101 and button 1 of address 92 corresponding to keyset 102.

#### 8. System Refresh Basis – (See Fig. 340-30)

System refresh (a “cleaning” of system RAM to remove any false data caused by AC voltage problems or other causes) can be set to begin after one of two criteria have been met for a period of approximately 5 hours:

- 1) There is no change in status; devices may be busy but no new activity has taken place in 5 hours.
- 2) All stations have been idle; all stations have been “receiver on hook” for 5 hours.

Address 93 is used to program this choice of system refresh basis. Button 1 is used in an either/or mode to select the style of refresh.

### 340.6 Memory Block 6

#### 1. Incoming Restriction Assignment – (See Fig. 340-31)

Memory block 6 has 96 addresses. Each CO/PBX line uses 6 addresses for incoming restriction. This allows assignment of all CO/PBX lines. Each address uses 8 buttons: each one corresponds to a station. This allows assignment for all 48 stations.

The default value for Memory block 6 is no station is restricted on any CO/PBX line.

### 340.7 Memory Block 7

#### 1. Speed Dial Excess Assignment – (Refer to Fig. 340-32)

This area of the program allows the assignment of Speed Dial – Station memories of non-installed stations to keysets which are installed. Thus a keyset can have 20 Speed Dialing Station memories. These memories must be reassigned when the corresponding station is installed. In the case where a keyset has been assigned another stations memories and at a later date the station is installed: Neither keyset can use its speed dial memories until the NPM is reprogrammed. Contents of the memories will be displayed as EE.

Addresses 1 ~ 48 are used to designate the recipient of the additional speed dial memories (address is equal to station number minus “1” prefix). The donating (non-installed) station number is then written in binary format using buttons 1 ~ 6. Default value for this area is that no keysets have additional speed dial memories.

#### 2) Attendant Overflow – (Refer to Fig. 340-33)

Attendant overflow allows a choice for intercom calls to an attendant to be redirected to the other attendant when the first attendant is busy. Only intercom calls directed to an attendant by dialing “0” will be redirected.

Address 50 is used to allow or disallow overflow from busy attendant. Button 1 is used on a yes/no basis. Default value for this area of the program is no overflow.

#### 3) SMDS Output Timer – (Refer to Fig. 340-34)

This area of the program is used to assign the minimum duration an outgoing CO/PBX call must provide for an SMDS output. Possible values are 0 seconds, 15 seconds or 30 seconds.

Address 51, Button 1 and 2 are used to select this timeout. The default value for this parameter is 15 seconds.

#### 4) SMDS Incoming Call – (Refer to Fig. 340-35)

This area of the program is used to select whether or not incoming CO/PBX calls will generate an SMDS report.

Address 50, Button 1 is used to make this choice. The default value is that incoming CO/PBX calls will generate a report.

**Table 340. 1 Memory Block and Address Content**

**MEMORY BLOCK 1**

<b>ADDRESS</b>	<b>FEATURE</b>
1 – 48	Prime Line Pickup Assignment
49 – 72	Station Class Assignment
73 – 76	CO/PBX Group Assignment
77 – 78	Line Assignment
79	Hold Recall Timing Assignment
80	Paging Timeout Assignment
81	Camp-on Recall Timing Assignment
82	MFR Timing Assignment
83	Hook-Flash Timing Assignment
85	#/* First Digit Restriction Assignment
86	Prime Line Pickup for Incoming CO/PBX Assignment
91	Attendant Exclusive Intercom Line Assignment
93	CO/PBX Assignment for Single Line Telephone Access

**MEMORY BLOCK 2**

1 – 96	Day Mode CO/PBX Ringing Assignment
--------	------------------------------------

**MEMORY BLOCK 3**

1 – 96	Night Mode CO/PBX Ringing Assignment
--------	--------------------------------------

**MEMORY BLOCK 4**

1 – 12	Internal Paging Zone Assignment
13 – 36	Call Pickup Zone Assignment
37 – 72	Station Attendant Assignment
43 – 54	Telephone Type Assignment
79	CO/PBX Line/Scan Assignment
80	Speed Dial Toll Override Assignment

**MEMORY BLOCK 5**

1	PBX Access Code Assignment
2 – 3	Digit Rejection Assignment
4	"1" +Dialing Assignment
5 – 64	Toll Restriction Override Table Assignment
81 – 86	Off Hook Ringing Assignment
90	DSS Installation Data
91 – 92	Attendant Automatic Answer
93	System Refresh Basis

**MEMORY BLOCK 6**

1 – 96	Incoming Restriction Assignment
--------	---------------------------------

**MEMORY BLOCK 7**

1 – 48	Speed Dial Excess Assignment
--------	------------------------------

MEMORY BLOCK:	1
ADDRESSES :	01 ~ 48

PRIME LINE	1	2	3	4	5
1					
2					
3					
4					
5					
6					
7					
8					
9					
10					
11					
12					
13					
14					
15					
16					

ADD.	STA.	1	2	3	4	5	ADD.	STA.	1	2	3	4	5
01	101						25	125					
02	102						26	126					
03	103						27	127					
04	104						28	128					
05	105						29	129					
06	106						30	130					
07	107						31	131					
08	108						32	132					
09	109						33	133					
10	110						34	134					
11	111						35	135					
12	112						36	136					
13	113						37	137					
14	114						38	138					
15	115						39	139					
16	116						40	140					
17	117						41	141					
18	118						42	142					
19	119						43	143					
20	120						44	144					
21	121						45	145					
22	122						46	146					
23	123						47	147					
24	124						48	148					

EXAMPLE: 15

STATION 115 IS ASSIGNED CO/PBX LINE 8 AS PRIME LINE.

Fig. 340-1 Prime Line Pickup Assignment

MEMORY BLOCK : 1  
 ADDRESSES : 49 ~ 72

STA. CLASS	CO GROUP			1	2	3	4
	A	B	C				
0	N	N	N	■	■	■	■
1	N	T	N	□	■	■	■
2	N	O	N	■	□	■	■
3	O	T	N	□	□	■	■
4	T	N	N	■	■	□	■
5	T	T	N	□	■	□	■
6	T	O	N	■	□	□	■
7	T	T	T	□	□	□	■
8	N	N	O	■	■	■	□
9	N	T	O	□	■	■	□
10	N	O	O	■	□	■	□
11	O	T	O	□	□	■	□
12	T	N	O	■	■	□	□
13	T	T	O	□	■	□	□
14	T	O	O	■	□	□	□
15	O	O	O	□	□	□	□

ADD.	STA.	1	2	3	4	STA.	5	6	7	8
49	101					102				
50	103					104				
51	105					106				
52	107					108				
53	109					110				
54	111					112				
55	113					114				
56	115					116				
57	117					118				
58	119					120				
59	121					122				
60	123					124				
61	125					126				
62	127					128				
63	129					130				
64	131					132				
65	133					134				
66	135					136				
67	137					138				
68	139					140				
69	141					142				
70	143					144				
71	145					146				
72	147					148				

EXAMPLE:

159



STATION 141 : CLASS 10

STATION 142 : CLASS 4

Fig. 340-2 Station Class Assignment

MEMORY BLOCK :	1
ADDRESSES :	73 ~ 76

CO PBX G R O U P	1	2
	3	4
	5	6
	7	8
	A ("9")	
	B ("8")	
	C ("7")	
	NO ASSG'T	

ADD.	CO	1	2	CO	3	4	CO	5	6	CO	7	8
73	1			2			3			4		
74	5			6			7			8		
75	9			10			11			12		
76	13			14			15			16		

EXAMPLE:

75



CO/PBX 9 = C  
 CO/PBX 10 = A  
 CO/PBX 11 = NO ASSIGNMENT  
 CO/PBX 12 = B

Fig. 340-3 CO/PBX Group Assignment

MEMORY BLOCK :	1
ADDRESSES :	77 ~ 78

CO	
PBX	

ADD.	LINE	1	LINE	2	LINE	3	LINE	4	LINE	5	LINE	6	LINE	7	LINE	8
77	1		2		3		4		5		6		7		8	
78	9		10		11		12		13		14		15		16	

EXAMPLE:

77



LINES 1-3 : CO

LINES 4-8 : PBX

Fig. 340-4 Line Assignment

MEMORY BLOCK :	1
ADDRESSES :	79

SEC.	1	2
30		
60		
120		
240		

EXAMPLE:



HOLD RECALL IS SET AT 60 SECONDS.

Fig. 340-5 Hold Recall Timing Assignment

MEMORY BLOCK :	1
ADDRESSES :	80

SEC.	1	2
90		
120		
∞		

EXAMPLE:



PAGING TIMEOUT IS SET AT INFINITY.

Fig. 340-6 Paging Timeout Assignment

MEMORY BLOCK :	1
ADDRESSES :	81

SEC.	1	2
30		
60		
120		
240		

EXAMPLE:



CAMP-ON RECALL IS SET AT 120 SECONDS.

Fig. 340-7 Camp-on Recall Timing Assignment

MEMORY BLOCK :	1
ADDRESSES :	82

SEC.	1	2	3
10			
15			
20			
25			
30			
35			

EXAMPLE:



MFR TIMING IS SET AT 15 SECONDS.

Fig. 340-8 MFR Timing Assignment



MEMORY BLOCK :	1
ADDRESSES :	83

SEC.	1	2
0.4		
1.0		
1.5		

EXAMPLE:



HOOK-FLASH TIMING IS SET AT 1.5 SECONDS.

Fig. 340-9 Hook-Flash Timing Assignment

MEMORY BLOCK :	1
ADDRESSES :	85

	1
ALLOW	
DISALLOW	

EXAMPLE:



"#" OR "\*" MAY BE SENT AS FIRST DIGIT. KEYSSET ACCESS CODE FOR LAST NUMBER DIALED IS "ADD-ON" + "\*" AND FOR SYSTEM SPEED DIAL IS "ADD-ON" + "#".

Fig. 340-10 #/\* First Digit Restriction Assignment

MEMORY BLOCK :	1
ADDRESSES :	86

1	<input type="checkbox"/>
ALLOW	<input checked="" type="checkbox"/>
DISALLOW	<input type="checkbox"/>

EXAMPLE:

86	<input type="checkbox"/>	<input type="checkbox"/>	<input type="checkbox"/>	<input type="checkbox"/>	<input type="checkbox"/>	<input type="checkbox"/>	<input type="checkbox"/>	<input type="checkbox"/>
----	--------------------------	--------------------------	--------------------------	--------------------------	--------------------------	--------------------------	--------------------------	--------------------------

WILL NOT PERMIT AN INCOMING CALL TO BE SEIZED BY PRIME LINE PICK-UP.

Fig. 340-11 Prime Line Pickup for Incoming Calls

MEMORY BLOCK :	1
ADDRESSES :	91

1	<input type="checkbox"/>
DSS EXC. ICM	<input checked="" type="checkbox"/>
NO DSS EXC. ICM	<input type="checkbox"/>

EXAMPLE:

91	<input checked="" type="checkbox"/>	<input type="checkbox"/>	<input type="checkbox"/>	<input type="checkbox"/>	<input type="checkbox"/>	<input type="checkbox"/>	<input type="checkbox"/>	<input type="checkbox"/>
----	-------------------------------------	--------------------------	--------------------------	--------------------------	--------------------------	--------------------------	--------------------------	--------------------------

DSS IS PROVIDED AN EXCLUSIVE ICM LINE.

Fig. 340-12 ATT. Exclusive ICM Line Assignment

MEMORY BLOCK :	1
ADDRESSES :	93

CLASS	C	B	A
LINE BUTTON	1	2	3

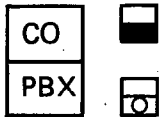

EXAMPLE:



CLASS A ("9") = CO  
 CLASS B ("8") = PBX  
 CLASS C ("7") = PBX

Fig. 340-13 CO/PBX Assignment for SLT Access

CO/ PBX	ADD.	STATION NUMBER								CO/ PBX	ADD.	STATION NUMBER								CO/ PBX	ADD.	STATION NUMBER																		
		1	2	3	4	5	6	7	8			1	2	3	4	5	6	7	8			1	2	3	4	5	6	7	8	1	2	3	4	5	6	7	8			
<b>1</b>	1	1	2	3	4	5	6	7	8	<b>5</b>	25	1	→								<b>9</b>	49	1	→							<b>13</b>	73	1	→						
	2	9	10	11	12	13	14	15	16		26											50										74								
	3	17	18	19	20	21	22	23	24		27											51										75								
	4	25	26	27	28	29	30	31	32		28											52										76								
	5	33	34	35	36	37	38	39	40		29											53										77								
	6	41	42	43	44	45	46	47	48		30									48		54								48		78								48
<b>2</b>	7	1	→						<b>6</b>	31	1	→							<b>10</b>	55	1	→						<b>14</b>	79	1	→									
	8									32										56										80										
	9									33										57										81										
	10									34										58										82										
	11									35										59										83										
	12							48		36								48		60									48	84								48		
<b>3</b>	13	1	→						<b>7</b>	37	1	→						<b>11</b>	61	1	→						<b>15</b>	85	1	→										
	14									38							62									86														
	15									39							63									87														
	16									40							64									88														
	17									41							65									89														
	18							48		42						48	66								48	90									48					
<b>4</b>	19	1	→						<b>8</b>	43	1	→					<b>12</b>	67	1	→					<b>16</b>	91	1	→												
	20									44						68								92																
	21									45						69								93																
	22									46						70								94																
	23									47						71								95																
	24							48		48						48		72						48		96								48						

RING	<input type="checkbox"/>
NO RING	<input type="checkbox"/>



BLOCK 2 ≈ DAY MODE



EXAMPLE:

73



MEMORY BLOCK 2

IN THE DAY MODE, CO-13 WILL RING AT STATIONS 101 THRU 107, BUT NOT AT STATION 108.

MEMORY BLOCK :	2
ADDRESSES :	1 ~ 96

Fig. 340-14 Day Mode CO/PBX Ringing Assignment

CO/ PBX	ADD.	STATION NUMBER								CO/ PBX	ADD.	STATION NUMBER								CO/ PBX	ADD.	STATION NUMBER								CO/ PBX	ADD.	STATION NUMBER							
		1	2	3	4	5	6	7	8			1	2	3	4	5	6	7	8			1	2	3	4	5	6	7	8			1	2	3	4	5	6	7	8
<b>1</b>	1	1	2	3	4	5	6	7	8	<b>5</b>	25	1	→							<b>9</b>	49	1	→							<b>13</b>	73	1	→						
	2	9	10	11	12	13	14	15	16		26										50										74								
	3	17	18	19	20	21	22	23	24		27										51										75								
	4	25	26	27	28	29	30	31	32		28										52										76								
	5	33	34	35	36	37	38	39	40		29										53										77								
	6	41	42	43	44	45	46	47	48		30							48	54							48	78								48				
<b>2</b>	7	1	→						<b>6</b>	31	1	→						<b>10</b>	55	1	→						<b>14</b>	79	1	→									
	8									32							56							80															
	9									33							57							81															
	10									34							58							82															
	11									35							59							83															
	12							48		36					48	60					48	84								48									
<b>3</b>	13	1	→						<b>7</b>	37	1	→					<b>11</b>	61	1	→					<b>15</b>	85	1	→											
	14									38						62						86																	
	15									39						63						87																	
	16									40						64						88																	
	17									41						65						89																	
	18							48		42				48	66					48	90								48										
<b>4</b>	19	1	→						<b>8</b>	43	1	→					<b>12</b>	67	1	→					<b>16</b>	91	1	→											
	20									44						68						92																	
	21									45						69						93																	
	22									46						70						94																	
	23									47						71						95																	
	24							48		48				48	72					48	96								48										

RING	
NO RING	

BLOCK 3 ≈ NIGHT MODE

EXAMPLE:

MEMORY BLOCK 3



IN THE NIGHT MODE, CO-13 WILL RING AT STATIONS 101 THRU 107, BUT NOT AT STATION 108.

MEMORY BLOCK :	3
ADDRESSES :	1 ~ 96

Fig. 340-15 Night Mode CO/PBX Ringing Assignment

MEMORY BLOCK :	4
ADDRESSES :	1 ~ 12

Z	1	2
O	3	4
N	5	6
E	7	8
1		
2		
3		
NO ZONE		

ADD.	STA.	1	2	STA.	3	4	STA.	5	6	STA.	7	8
1	1			2			3			4		
2	5			6			7			8		
3	9			10			11			12		
4	13			14			15			16		
5	17			18			19			20		
6	21			22			23			24		
7	25			26			27			28		
8	29			30			31			32		
9	33			34			35			36		
10	37			38			39			40		
11	41			42			43			44		
12	45			46			47			48		

EXAMPLE:

- STA. 37 : ZONE 1
- STA. 38 : ZONE 1
- STA. 39 : ZONE 3
- STA. 40 : ZONE 2

Fig. 340-16 Internal Paging Zone Assignment

MEMORY BLOCK : 4  
 ADDRESSES : 13 ~ 36

ZONE	1	2	3	4
	5	6	7	8
1				
2				
3				
4				
5				
6				
7				
8				
9				
10				
11				
12				
13				
14				
15				
NO ZONE				

ADD.	STA.	1	2	3	4	STA.	5	6	7	8
13	1					2				
14	3					4				
15	5					6				
16	7					8				
17	9					10				
18	11					12				
19	13					14				
20	15					16				
21	17					18				
22	19					20				
23	21					22				
24	23					24				
25	25					26				
26	27					28				
27	29					30				
28	31					32				
29	33					34				
30	35					36				
31	37					38				
32	39					40				
33	41					42				
34	43					44				
35	45					46				
36	47					48				

EXAMPLE:



STA. 19 : ZONE 4  
 STA. 20 : ZONE 10

Fig. 340-17 Call Pickup Zone Assignment





MEMORY BLOCK :	4
ADDRESSES :	79

CO LINE	1	2	3	4	5
0	■	■	■	■	■
1	□	■	■	■	■
2	■	□	■	■	■
3	□	□	■	■	■
4	■	■	□	■	■
5	□	■	□	■	■
6	■	□	□	■	■
7	□	□	□	■	■
8	■	■	■	□	■
9	□	■	■	□	■
10	■	□	■	□	■
11	□	□	■	□	■
12	■	■	□	□	■
13	□	■	□	□	■
14	■	□	□	□	■
15	□	□	□	□	■
16	■	■	■	■	□

**Note:** The default value is 0. In this state, the system will start with CO/PBX Line 1 and scan forward in numerical order. All other values result in a scan against numerical order from the CO/PBX Line programmed.

EXAMPLE: 79 □ □ □ □ □ □ □ □

CO LINE SCAN BEGINS BACKWARDS WITH LINE 13.

Fig. 340-20 CO/PBX Line Scan Assignment

MEMORY BLOCK :	4
ADDRESSES :	80

1	
ALLOW	
DISALLOW	

EXAMPLE:

80								
----	--	--	--	--	--	--	--	--

SYSTEM SPEED DIAL IS RESTRICTED.

Fig. 340-21 Speed Dial Toll Override Assignment

MEMORY BLOCK :	5
ADDRESSES :	01

PBX CODE	DIGIT #1				DIGIT #2			
	1	2	3	4	5	6	7	8
1								
2								
3								
4								
5								
6								
7								
8								
9								
0								
NONE								

EXAMPLE: 

1								
---	--	--	--	--	--	--	--	--

NO PBX ACCESS CODE HAS BEEN ASSIGNED.

Fig. 340-22 PBX Access Code Assignment

MEMORY BLOCK :	5
ADDRESSES :	02 ~ 03

DIGIT	1	2	3	4
	5	6	7	8
1				
2				
3				
4				
5				
6				
7				
8				
9				
0				
NONE				

ADD.	1	2	3	4	5	6	7	8
02	DIGIT 1				DIGIT 2			
03	DIGIT 3				DIGIT 4			

ADD.	1	2	3	4	5	6	7	8
02								
03								

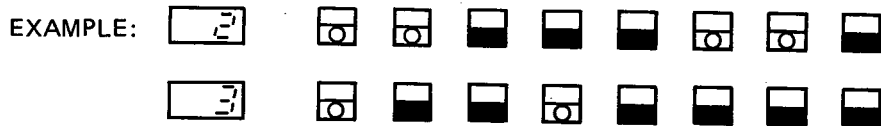

SYSTEM PROGRAMMED TO RELEASE LINE WHEN FIRST DIGIT IS 3, 6, OR 9.

Fig. 340-23 Digit Rejection Assignment

MEMORY BLOCK :	5
ADDRESSES :	04

1
ALLOW
DISALLOW

EXAMPLE: 

SYSTEM IS PROGRAMMED TO PERMIT "1" + DIALING.

Fig. 340-24 "1" + Dialing Assignment.

MEMORY BLOCK :	5
ADDRESSES :	05 ~ 64

DIGIT	1	2	3	4
1				
2				
3				
4				
5				
6				
7				
8				
9				
0				

ADD.	1	2	3	4	5	6	7	8
05	CODE DIG. 1				CODE DIG. 2			
06	CODE DIG. 3							
07	CODE DIG. 1							
08	CODE DIG. 3							
09	CODE DIG. 1							
10	CODE DIG. 3							
63	CODE DIG. 1							
64	CODE DIG. 3							

TABLE ENDING MUST BE SET AS FOLLOWS:

1	2	3	4	5	6	7	8

EXAMPLE:

EXAMPLE: 

THE FIRST 3-DIGIT CODE IN THIS TABLE IS 212.

Fig. 340-25 Toll Restriction Override Table Assignment

### TOLL OVERRIDE TABLE CHART

NO.	ADD.	1	2	3	4	5	6	7	8
1	05								
	06								
2	07								
	08								
3	09								
	10								
4	11								
	12								
5	13								
	14								
6	15								
	16								
7	17								
	18								
8	19								
	20								
9	21								
	22								
10	23								
	24								
11	25								
	26								
12	27								
	28								
13	29								
	30								
14	31								
	32								
15	33								
	34								

NO.	ADD.	1	2	3	4	5	6	7	8
16	35								
	36								
17	37								
	38								
18	39								
	40								
19	41								
	42								
20	43								
	44								
21	45								
	46								
22	47								
	48								
23	49								
	50								
24	51								
	52								
25	53								
	54								
26	55								
	56								
27	57								
	58								
28	59								
	60								
29	61								
	62								
30	63								
	64								

Fig. 340-26

MEMORY BLOCK :	5
ADDRESSES :	81 ~ 86

1

NO OFF HOOK RINGING



OFF HOOK RINGING



ADD.	STA. 1	STA. 2	STA. 3	STA. 4	STA. 5	STA. 6	STA. 7	STA. 8
81	1	2	3	4	5	6	7	8
82	9	10	11	12	13	14	15	16
83	17	18	19	20	21	22	23	24
84	25	26	27	28	29	30	31	32
85	33	34	35	36	37	38	39	40
86	41	42	43	44	45	46	47	48

EXAMPLE: 81

STA. 1 ~ 4 NO OFF HOOK RINGING.  
STA. 5 ~ 8 OFF HOOK RINGING.

Fig. 340-27 Off Hook Ringing Assignment

MEMORY BLOCK :	5
ADDRESS :	90

EXAMPLE:

DSS INST.

1 2

90

NONE



BOTH DSS/BLFs ARE INSTALLED.

#1



BOTH

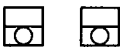

Fig. 340-28 DSS Installation Data

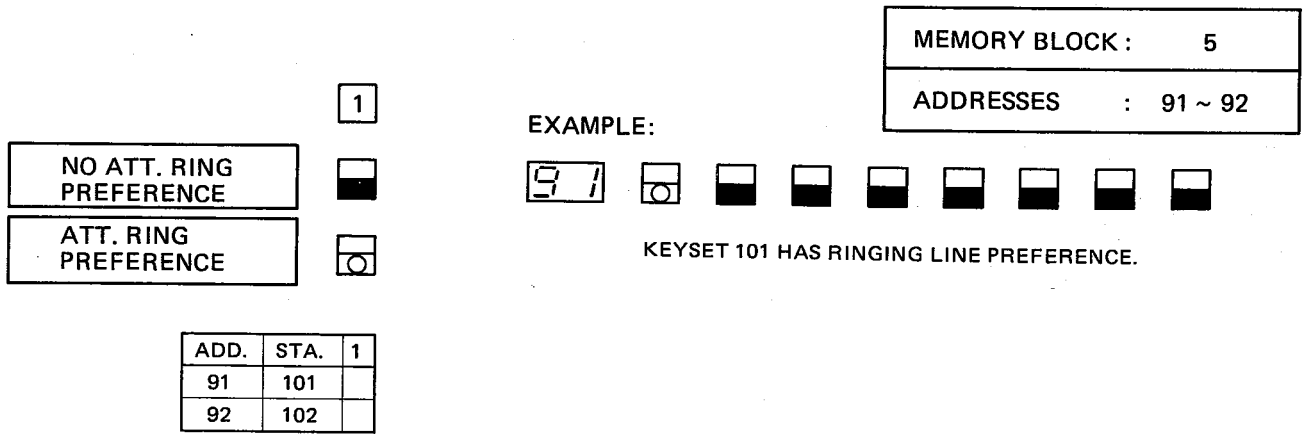

Fig. 340-29 Attendant Automatic Answer

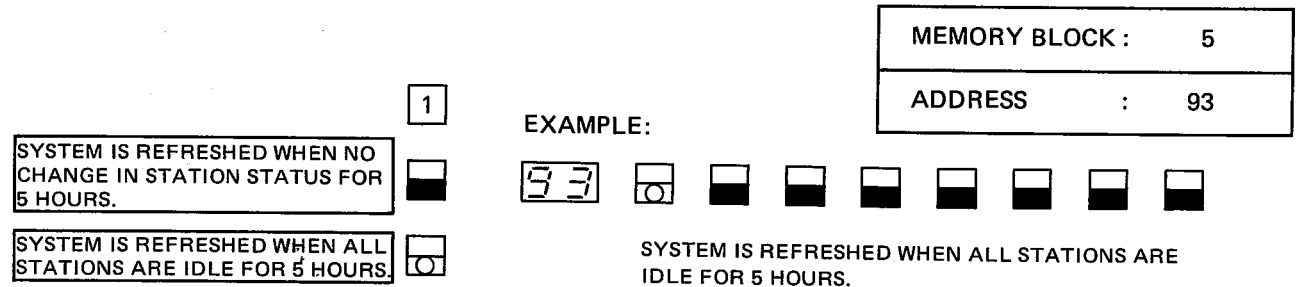

Fig. 340-30 System Refresh Basis

CO/ PBX	ADD.	STATION NUMBER								CO/ PBX	ADD.	STATION NUMBER								CO/ PBX	ADD.	STATION NUMBER								CO/ PBX	ADD.	STATION NUMBER												
		1	2	3	4	5	6	7	8			1	2	3	4	5	6	7	8			1	2	3	4	5	6	7	8			1	2	3	4	5	6	7	8					
<b>1</b>	1	1	2	3	4	5	6	7	8	<b>5</b>	25	1	→								<b>9</b>	49	1	→								<b>13</b>	73	1	→									
	2	9	10	11	12	13	14	15	16		26												50											74										
	3	17	18	19	20	21	22	23	24		27													51											75									
	4	25	26	27	28	29	30	31	32		28													52											76									
	5	33	34	35	36	37	38	39	40		29													53											77									
	6	41	42	43	44	45	46	47	48		30											48	54								48		78								48			
<b>2</b>	7	1	→						<b>6</b>	31	1	→								<b>10</b>	55	1	→								<b>14</b>	79	1	→										
	8									32											56											80												
	9									33											57											81												
	10									34											58											82												
	11									35											59											83												
	12							48		36								48	60								48	84									48							
<b>3</b>	13	1	→					<b>7</b>	37	1	→							<b>11</b>	61	1	→							<b>15</b>	85	1	→													
	14								38								62								86																			
	15								39								63								87																			
	16								40								64								88																			
	17								41								65								89																			
	18								48	42						48	66							48	90									48										
<b>4</b>	19	1	→					<b>8</b>	43	1	→						<b>12</b>	67	1	→						<b>16</b>	91	1	→															
	20								44							68							92																					
	21								45							69							93																					
	22								46							70							94																					
	23								47							71							95																					
	24								48	48						48		72					48	96									48											

INCOMING RESTRICTED	<input type="checkbox"/>
NOT INCOMING RESTRICTED	<input type="checkbox"/>



EXAMPLE:

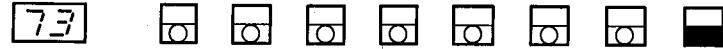

CO/PBX LINE 13 IS INCOMING RESTRICTED ON STATIONS 101 ~ 107 BUT IS NOT INCOMING RESTRICTED ON STATION 108.

MEMORY BLOCK :	6
ADDRESSES :	1 ~ 96

Fig. 340-31 Incoming Restriction Assignment



MEMORY BLOCK :	7
ADDRESSES :	1 ~ 48

EXAMPLE:

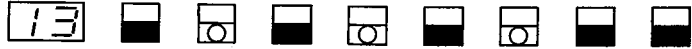

KEYSET 13 CAN USE THE STATION SPEED DIAL MEMORIES OF STATION 42.

STA.	1	2	3	4	5	6	7	8	STA.	1	2	3	4	5	6	7	8	STA.	1	2	3	4	5	6	7	8
1	○	■	■	■	■	■	■	■	17	○	■	■	■	○	■	■	■	33	○	■	■	■	○	■	■	■
2	■	○	■	■	■	■	■	■	18	■	○	■	■	○	■	■	■	34	■	○	■	■	○	■	■	■
3	○	○	■	■	■	■	■	■	19	○	○	■	■	○	■	■	■	35	○	○	■	■	○	■	■	■
4	■	■	○	■	■	■	■	■	20	■	■	○	■	○	■	■	■	36	■	■	○	■	○	■	■	■
5	○	■	○	■	■	■	■	■	21	○	■	○	■	○	■	■	■	37	○	■	○	■	○	■	■	■
6	■	○	○	■	■	■	■	■	22	■	○	○	■	○	■	■	■	38	■	○	○	■	○	■	■	■
7	○	○	○	■	■	■	■	■	23	○	○	○	■	○	■	■	■	39	○	○	○	■	○	■	■	■
8	■	■	■	○	■	■	■	■	24	■	■	○	○	■	■	■	■	40	■	■	○	○	○	■	■	■
9	○	■	○	■	■	■	■	■	25	○	■	○	○	■	■	■	■	41	○	■	○	○	○	○	■	■
10	■	○	■	○	■	■	■	■	26	■	○	○	○	○	■	■	■	42	■	○	○	○	○	○	○	■
11	○	○	■	○	■	■	■	■	27	○	○	■	○	○	■	■	■	43	○	○	■	○	○	○	○	■
12	■	■	○	○	■	■	■	■	28	■	■	○	○	○	■	■	■	44	■	■	○	○	○	○	○	■
13	○	■	○	○	■	■	■	■	29	○	■	○	○	○	■	■	■	45	○	■	○	○	○	○	○	■
14	■	○	○	○	■	■	■	■	30	■	○	○	○	○	■	■	■	46	■	○	○	○	○	○	○	■
15	○	○	○	○	■	■	■	■	31	○	○	○	○	○	■	■	■	47	○	○	○	○	○	○	○	■
16	■	■	■	○	■	■	■	■	32	■	■	■	○	○	■	■	■	48	■	■	■	○	○	○	○	■

WRITING STATION NUMBERS IN BINARY.

ADDRESS IS EQUAL TO STATION NUMBER.

ADD.	1	2	3	4	5	6	7	8	ADD.	1	2	3	4	5	6	7	8	ADD.	1	2	3	4	5	6	7	8
1									17									33								
2									18									34								
3									19									35								
4									20									36								
5									21									37								
6									22									38								
7									23									39								
8									24									40								
9									25									41								
10									26									42								
11									27									43								
12									28									44								
13									29									45								
14									30									46								
15									31									47								
16									32									48								

Fig. 340-32 Speed Dial Excess Assignment

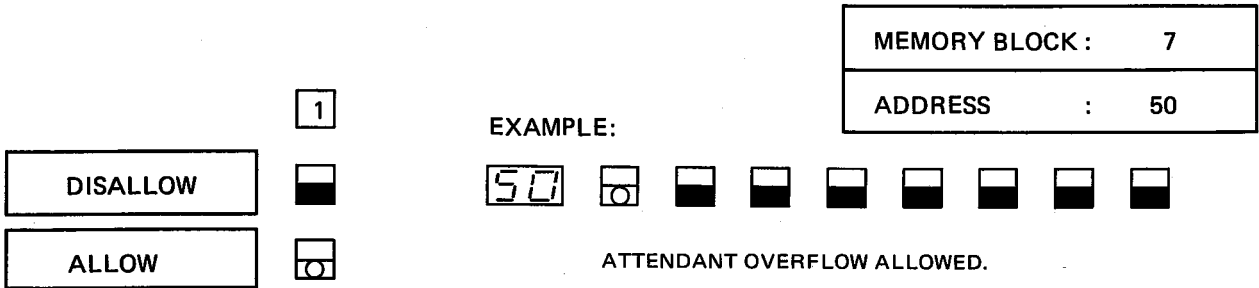

**Fig. 340-33 Attendant Overflow**

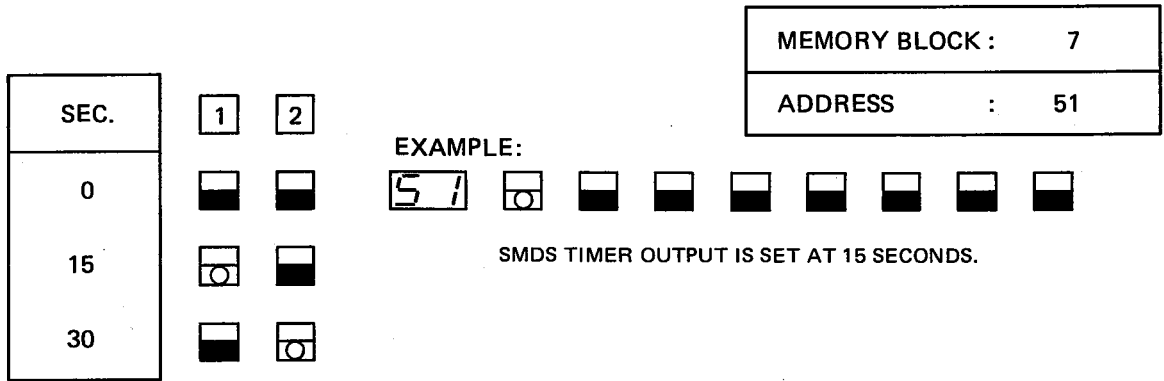

**Fig. 340-34 SMDS Timer Output**

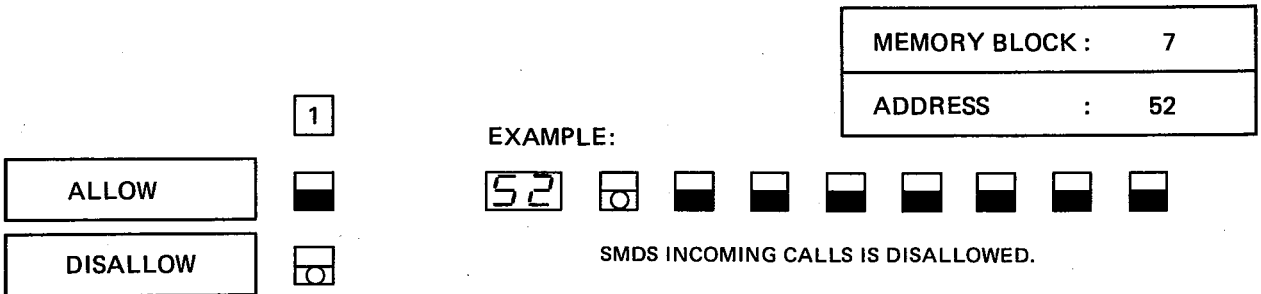

**Fig. 340-35 SMDS Incoming Calls**



## SECTION 400 STATION OPERATION PROCEDURE

### 410 Key Telephone Operation

#### 410.1 CO/PBX (Outside) Calls

##### 1. Originating

###### Using Manual Dialing

- depress idle (unlit)  CO
- lift handset or depress  ON  
 OFF
- receive dial tone
- dial desired number
- when party answers, use handset to talk

###### Using Last CO/PBX Number Redial

- depress idle (unlit)  CO
- lift handset or depress  ON  
 OFF
- receive dial tone
- dial  \* (access code may be changed to  ADD  
 ON +  \* on a system basis).
- when party answers, use handset to talk

###### Using Speed Dialing – Station

- lift handset or depress  ON  
 OFF
- depress desired  DSS
- when party answers, use handset to talk

**Note:** Use of DSS can automatically provide an acceptable CO/PBX line. Depress  CO before depressing  DSS for a particular CO/PBX line or if "0" has been programmed for access code.

###### Using Speed Dialing – System

- depress idle (unlit)  CO
- lift handset or depress  ON  
 OFF
- receive dial tone

- dial  #,  1, and a digit  0 ~  9 for the particular number desired (access code may be changed to  ADD  
 ON +  # on a system basis).

- when party answers, use handset to talk

###### Using Prime Line Pickup

- lift handset
- receive dial tone
- use any of the dialing methods discussed here

###### Using Consecutive Dialing

**Note:** After using any dialing method: to initiate system speed dial operation first depress  ADD  
 ON .  ADD  
 ON flashes.

- depress idle (unlit)  CO
- lift handset or depress  ON  
 OFF
- use station or system speed dialing or manually dial
- receive confirmation tone
- use station or system speed dialing or manually dial
- receive confirmation tone
- use station or system speed dialing or manually dial
- repeat procedure as many times as desired
- when party answers, use handset to talk

Sequential dialing of this type has value when used with a tandem network, when accessing certain computer-type equipment, and for specialized common carrier services.

##### 2. Answering

###### When a Flashing CO Present on Keypad

- depress flashing  CO
- lift handset
- respond to caller

(See also Call Pickup and Night Mode)

### 3. Placing a Call on Hold

#### Placing a CO/PBX Call on Manual Hold

- during CO/PBX conversation, depress **HOLD** once or,
- depress **DSS** programmed for ICM call. The call in progress will automatically be put on hold.

#### Placing a CO/PBX Call on Exclusive Hold

- during CO/PBX conversation, depress **HOLD** twice

#### Removing a CO/PBX Line from Hold

- depress winking **CO**
- lift handset

**Note:** *An audible recall signal and a fluttering CO/PBX LED is provided to idle keysets that have left a CO/PBX line on exclusive hold for longer than the programmable time. Removing a recalled line from hold is done with the same procedure as above.*

### 4. Abandoning a Call

#### Abandoning CO Call Using Recall Button

- at the end of the call depress **RECALL**
- CO call is released but the line is retained and new dial tone is heard
- dial next call

#### Abandoning Using Handset

- restore handset
- CO/PBX line is released.

#### Abandoning when in Monitor Mode

- depress **ON/OFF**
- **ON/OFF** LED goes off and CO/PBX line is released.

## 410.2 Intercom (Internal) Calls

### 1. Originating

#### Originating Using DSS Button

- lift handset or depress **ON/OFF**
- depress **DSS** for desired station
- (if a previous CO/PBX call was in progress, the call is placed on hold automatically).
- receive tone burst when keyset is called or ringback when single line set is called
- after tone burst, page using handset or dial **1** for tone signal. (keyset called)
- after response, use handset to talk

#### Origination Using Manual Dialing

- depress **ICM**
- lift handset or depress **ON/OFF**
- receive dial tone
- dial desired station number **1**, **x**, **x**, (or just **0** to call attendant)
- display shows last 2 digits dialed **x x**
- receive tone burst when keyset is called or ringback when single line set is called.
- after tone burst, page using handset or dial **1** for tone signal. (Keyset called)
- after response, use handset to talk

#### Origination to a Busy Station

- when the above procedures are used to call a busy station, call waiting tone is returned to the caller. At a called keyset the **ICM** led flashes and no audible tone is heard. The following procedures may then be used:
  1. abandon the call
  2. monitor the call waiting tone, when it stops the intercom call will proceed
  3. use automatic callback feature
  4. use call waiting-tone override feature
  5. use callback request feature

### Using Automatic Callback Feature

- upon receiving call waiting tone dial **0**, display shows **C b**
- restore the handset or depress **ON/OFF** LED goes off
- when called party is idle, system will send ring-back tone to calling station
- after calling station answers, system will send a tone burst or ring to called party. Called keyset display shows calling stations last two digits **x x**
- after tone burst, calling station can page using handset or dial **1** for tone signal

### Using Call Waiting – Tone Override Feature

- upon receiving call waiting tone, dial **\***. Display shows **0**
- a tone will be heard by the called station, who can now place current call on hold and respond to your call.
- keyset display will show last 2 digits **x x** of calling station. Display will remain until either called party answers ICM call or calling party hangs-up.

### Using Callback Request Feature to an Unattended or Busy Keyset

- when a keyset does not respond to an intercom call, a message can be left using the callback Number Display Feature
- if keyset is busy receive call waiting tone
- dial **#**
- receive confirmation tone, display shows **5**
- restore the handset or depress **ON/OFF** if in handsfree dialing mode
- when idle, called keyset's display will flash last 2 digits **x x** of calling station

**Note:** Up to three displays per called keyset, 48 per system, further attempts will receive error tone. Display will show **d** on calling keyset when attempt fails.

## 2. Hold

### Placing an Intercom Call on Exclusive Hold

- during intercom conversation, depress **HOLD** once (**HOLD** now winks)

### Taking an Intercom Call Off of Exclusive Hold

- lift handset or depress **ON/OFF**
- depress winking **HOLD**

**Note:** Called keyset must answer intercom call with handset before hold will work.

## 410.3 Conferencing

**Note:** When all conference circuits are busy **ADD/ON** will light on all keysets. No additional conference can be made at this time.

The allowable conferences are:

3 stations	1 CO/PBX line
2 stations	1 CO/PBX line
1 station	2 CO/PBX lines
3 stations	No CO/PBX lines

### 1. Originating

#### Three Party Conference

(1 station 2 CO/PBX lines or 2 stations 1 CO/PBX line or 3 stations)

With first call in progress (1 station 2 CO/PBX lines or 2 stations 1 CO/PBX line or 3 stations)

- depress **HOLD**
- originate second call and wait for called party to answer
- depress **ADD/ON**, **ADD/ON** flashes
- depress winking **CO** or **HOLD** (if first call is ICM). **ADD/ON** is lit
- use handset to talk

## Four Party Conference

(3 stations 1 CO/PBX)

With 3 party conference in progress

- depress **HOLD**
- originate third call and wait for called party to answer
- depress **ADD ON** , **ADD ON** flashes
- depress winking **HOLD** , **ADD ON** is lit
- use handset to talk

## 2. Holding

### 1 Station 2 CO/PBX Conference

- depress **HOLD** , both **CO** wink

**Note:** This allows individual handling of the two CO/PBX calls. Conversation cannot continue during the stations absence.

### All Other Conferences

- depress **HOLD** , **HOLD** winks

**Note 1:** This allows re-entry by the station at a later time.

**Note 2:** Four Party Conference cannot be put on hold.

### The Procedure for Re-Entry is

- lift handset
- depress winking **HOLD**
- use handset to talk

Conversation can continue during the station's absence. If the conference is ended during the station's absence, **HOLD** will go off.

## 3. Abandoning a Conference

### 1 Station 2 CO/PBX Conference

- restore handset, both **CO** go off. All connections ended

### All Other Conferences

- restore handset. Remaining parties can continue to talk

## 410.4 Transfer

### Transfer of CO/PBX Line between Keysets when both have the CO/PBX Line Appearance

- during conversation, either
  - depress desired **DSS** , **CO** winks
- or
- depress **HOLD** , **CO** winks
- depress **ICM**
- dial desired station **1** , **x** , **x**
- after receiving tone burst, voice page to request that called station pick-up held CO/PBX line
- wait for response or monitor held CO/PBX line status until answered (CO lit)
- restore handset

### Transfer of any Call to an Idle Station without that CO/PBX Line Appearance

- during conversation, either
  - depress desired **DSS**
- or
- depress **HOLD**
- depress **ICM**
- receive dial tone
- dial desired station number **1** , **x** , **x**
- **CO** or **HOLD** is winking, tone burst or ringback is heard
- called party must respond using their handset
- depress **ADD ON** , **ADD ON** flashes
- depress winking **CO** or **HOLD** , **ADD ON** is lit
- restore the handset

## 410.5 Do Not Disturb

### To Enter Do Not Disturb Mode

- depress .  is lit

### To Leave Do Not Disturb Mode

- depress ,  is off

## 410.6 Message Waiting

- flashes
- call   attendant to determine message

## 410.7 Call Pick-up

To pick-up a call to a station within your Call Pick-up group.

- depress
- lift handset or depress
- receive dial tone
- dial
- use handset to talk

## 410.8 Call Forwarding

To re-route intercom calls and CO/PBX calls transferred by DSS/BLF attendant to another station.

- depress
- lift handset or depress
- receive dial tone
- dial ,
- dial desired station number , ,
- keyset display shows  , last 2 digits of selected station
- dial  for “all calls”  
dial  for “busy”.
- If no digit is dialed, call forwarding – all calls is set.
- receive set tone and  is lit
- restore handset or depress

## To Remove Call Forwarding

- depress
- lift handset or depress
- receive dial tone
- dial ,
- goes off
- restore handset or depress

## To Display Call Forwarding Status at Keyset

- depress
- lift handset or depress
- receive dial tone
- dial ,
- display briefly shows  , last 2 digits of selected station when keyset is call forwarded.
- display shows   when keyset is not call forwarded

## 410.9 Night Mode

### To Enter Night Mode (Attendant Keyset Only)

- depress
- lift handset or depress
- receive dial tone
- dial ,
- display shows
- restore handset or depress

### To Cancel Night Mode (Attendant Keyset Only)

- depress
- lift handset or depress
- receive dial tone
- is removed from display



- dial **4**, **9**
- display shows **4 9** briefly
- restore handset or depress **ON OFF**

#### Night Call Pickup

When the system is in night mode and a CO/PBX call is ringing, if your keyset does not have the CO/PBX line appearance,

- depress **ICM**
- lift handset
- dial **3**
- use the handset to talk

### 410.10 Internal 3-Zone Paging

#### To Originate an Internal Zone Page

- depress **ICM**
- lift the handset or depress **ON OFF**
- receive dial zone
- dial **5**, **1** for Zone 1
- 5**, **2** for Zone 2
- 5**, **3** for Zone 3
- 5**, **0** for All Call
- use handset to page

#### To Answer an Internal Zone Page

- depress **ICM**
- lift the handset or depress **ON OFF**
- receive dial tone
- dial **5**, **5**
- use the handset to talk

### 410.11 External 3-Zone Paging

#### To Originate an External Zone Page

- depress **ICM**
- lift handset or depress **ON OFF**
- receive dial tone
- dial **6**, **1** for Zone 1
- 6**, **2** for Zone 2
- 6**, **3** for Zone 3
- 6**, **0** for All Zones
- use handset to page

#### To Answer an External Zone Page

- depress **ICM**
- lift handset or depress **ON OFF**
- receive dial tone
- dial **6**, **5**
- use handset to talk

### 410.12 Programming DSS Buttons

**Note:** DSS Buttons 1 ~ 20 can be used for intercom and DSS Buttons 11 ~ 20 can be used for CO/PBX calls. Where Speed Dial Excess assignment is applied to a keyset, DSS Buttons 1 ~ 20 can be used for CO/PBX calls.

#### To Program

- ensure keyset is on-hook
- depress **ADD ON**, **ADD ON** winks
- depress selected **DSS**
- dial access code
- 1** for intercom
- 7**, **8**, **9**, or **0** for CO/PBX access

**Note:** 0 does not provide automatic CO/PBX access.

– dial the rest of the number desired (2 digits for ICM)

– depress  ,  is off

**Note:** While programming (ADD/ON winks) the telephone is put into a busy condition.

#### To Check Memory Contents

– depress  (do not lift handset or depress  )

– each digit is displayed for almost 1 second

### 410.13 Programming Speed Dial – System Memories (Attendant Keypad Only)

#### To Program

– ensure attendant keypad is on-hook

– depress  ,  winks

– dial stored address digits  ,  ~

– dial  ,  or  for line selection

– dial telephone number

– depress  ,  is off

**Note:** While programming (ADD/ON winks) the attendant keypad is put into a busy condition.

#### To Check Memory Contents (Attendant Keypad Only)

– depress  or lift handset

– depress

– dial  ,

– dial stored address digits  ,  ~

– each digit is displayed for almost 1 second

– depress  or restore the handset

### 410.14 Attendant Keypad Display Priorities

**Top Priority** – Display of calling party, called party or speed dial numbers.

**Second Priority** – Display “00” until program is accepted.

**Third Priority** – Display “48” when Night Mode is set.

**Lowest Priority** – Callback request display.

## 420 Single Line Telephone Operation

### 420.1 CO/PBX (Outside) Calls

#### 1. Originating

##### Manually Dialed

- lift handset
- receive dial tone
- dial  or  or  for desired CO/PBX line class
- receive dial tone
- dial telephone number

##### Last CO/PBX Number Redial

- lift handset
- receive dial tone
- dial

##### Speed Dial – Station

- lift handset
- receive dial tone
- dial ,  and address digit  ~

##### Speed Dial – System

- lift handset
- receive dial tone
- dial ,  and address digit  ~

#### 2. Holding

##### Placing a Call on Exclusive Hold

- during conversation flash switchhook
- receive interrupted hold tone
- restore handset

##### Removing a Call from Exclusive Hold

- lift handset
- receive dial tone
- flash switchhook

#### 3. Answering

##### When CO/PBX Incoming Ring is Heard

- lift handset

#### 4. Abandoning

- restore handset

### 420.2 Intercom (Internal) Calls

#### 1. Originating

##### To Call a Station

- lift handset
- receive dial tone
- dial 3 digit station number , ,  (or just  for attendant)

##### Originating to a Busy Station

When the originated intercom call is to a busy station, call waiting tone is received. There is no audible tone at a called keyset and the ICM LED will flash if the called keyset is not using ICM. The following procedures may then be used:

- 1) abandon the call.
- 2) monitor the call waiting tone, when it ends the intercom call will be processed.

#### 2. Holding

##### Placing a Call on Exclusive Hold

- during conversation flash switchhook
- receive interrupted hold tone
- restore the handset

##### Removing a Call from Exclusive Hold

- lift handset
- receive dial tone or interrupted tone if handset was not restored
- flash switchhook
- resume conversation

### 3. Answering

#### When Intercom Call Ringing Signal is Heard

- lift handset

### 420.3 Conferencing

#### 1. Originating

##### 3 Party Conference

2 CO/PBX, 1 Station

1 CO/PBX, 2 Stations

3 Stations

- originate or answer first call in normal manner. (If an intercom call, called party must answer)
- flash switchhook
- receive interrupted hold tone
- originate second call in normal manner (If an intercom call, called party must answer).
- flash switchhook
- 3 party conference is complete

**Note:** *When a CO/PBX party abandons a conference, the whole conference must be abandoned. Where there is more than one station, any station may abandon and conversation may continue.*

### 420.4 Transferring

#### Any Call to an Idle Station

- during conversation, flash switchhook
- received interrupted hold tone
- dial desired station number , ,
- called party must respond using their handset
- flash switchhook
- restore handset

### 420.5 Call Pick-up

To pick-up a call to a station within your Call Pick-up group.

- lift the handset
- receive dial tone
- dial

### 420.6 Call Forwarding

#### To forward Intercom Calls and DSS/BLF Transferred CO/PBX Calls to Another Station

- lift the handset
- receive dial tone
- dial ,
- dial desired station number , ,
- dial  for “all calls”  
dial  for “busy”.
- If no digit is dialed, call forwarding – all calls is set.
- receive confirmation tone
- restore handset

#### To Remove Call Forwarding from Your Telephone

- lift handset
- receive dial tone
- dial ,
- restore handset

### 420.7 Night Call Pickup

#### Upon Hearing CO/PBX Incoming Signal when System is in Night Mode

- lift the handset
- receive dial tone
- dial
- use handset to talk

## 420.8 Internal 3-Zone Paging

### To Originate an Internal Zone Page

- lift handset
- receive dial tone
- dial ,  for Zone 1.  
,  for Zone 2.  
,  for Zone 3.  
,  for All call.
- use handset to talk

### To Answer an Internal Zone Page

- lift the handset
- receive dial tone
- dial ,

## 420.9 External 3-Zone Paging (Option)

### To Originate an External Zone Page

- lift the handset
- receive dial tone
- dial ,  for Zone 1.  
,  for Zone 2.  
,  for Zone 3.  
,  for All Zones.
- use handset to talk

## 420.10 Programming Speed Dial – Station

- lift the handset
- receive dial tone
- dial ,
- dial stored address digits ,  ~
- dial ,  or  for line selection
- dial telephone number
- restore handset

## 430 DSS/BLF Operation

The DSS/BLF is used in conjunction with a keyset. The keyset retains all features and operates as normal, the DSS/BLF only adds to these features.

### 430.1 CO/PBX (Outside) Calls

#### 1. Transfer by Announcement to Idle Keyset

##### After Answering a CO/PBX Call as Normal

- depress desired station's  DSS button.  
 CO winks
- after tone burst, voice announce call to keyset
- wait for response or for  CO status to change to busy:  CO is lit
- restore the handset

#### 2. Transfer to Any Idle Station, Camp-On to Any Busy Station

##### After Answering CO/PBX Call as Normal

- depress desired stations  DSS button.  
 CO winks
- depress  XFR .  CO is lit, display shows  C .
- restore the handset

The call is ringing if sent to idle station or camped-on if sent to busy station.

If call is not answered within a programmable time, it will return and tone signal (attendant keyset idle) or buzzer (attendant keyset busy) will be heard.

### 430.2 Intercom (Internal) Calls

##### To Originate

- lift the handset
- depress desired  DSS (one is provided for each station)

### 430.3 Night Mode

##### To Enter Night Mode

- lift handset or depress  ON  
 OFF
- depress  NT ,  NT is lit
- keyset display shows  4  8

##### To Leave Night Mode

- lift handset or depress  ON  
 OFF
- depress  NT ,  NT is off
- keyset display shows  4  9 briefly

### 430.4 Internal and External Zone Paging

##### To Make an Internal or External Zone Page

- lift handset
- depress  DSS for desired type and area of zone paging

### 430.5 Message Waiting

##### To Set Message Waiting at a Keyset

- depress  MW ,  MW is lit
- depress  DSS for desired keyset.  
 MW is off and green station LED is on.

##### To Remove Message Waiting

- depress  MW ,  MW is lit
- depress  DSS for desired keyset.  
 MW is off and green station LED is off.

### 430.6 Buzzer Control

The DSS/BLF contains a buzzer which provides audible signal of incoming CO/PBX calls and recalls to the attendant when the keyset is busy.

##### To Turn Buzzer Off

- depress  BZ ,  BZ is lit

##### To Turn Buzzer On

- depress  BZ ,  BZ is off

##### To Control Volume of Buzzer

- use turnwheel on lower front face of DSS/BLF

### 430.7 DSS/BLF and BLF Visual Indications

#### 1. DSS/BLF and BLF LED Priority

- 1) Top Priority – Flashing  
(Attendant cannot Override)
- 2) Second Priority – Winking  
(Attendant can Override)
- 3) Third Priority – Steady  
(Attendant can Override)
- 4) Lowest Priority – Idle  
(Attendant can Override)

#### 2. Visual Indications for DSS/BLF and BLF Units

##### Steady LED (Attendant can Override)

- Off Hook without depressed line button
- Receiving call waiting tone (Key Tel)
- Receiving busy tone (Key Tel)
- Talking on CO/PBX or ICM call
- Originating any paging or ICM call (Key Tel)
- During Add-On conference
- Receiving voice or tone signal for ICM call (Key Tel)
- Receiving internal paging (Key Tel)

##### Flashing LED (Attendant cannot Override)

- Having a call waiting party
- Hold recall, camp-on recall
- Automatic callback
- Programming system data
- Getting tone override
- Hook flash
- SLT receives a dial tone or other tones  
(CWT, Busy, 2nd Dial Tone, etc.)
- Store speed dial
- Camped-on
- SLT receives tone signal for ICM call
- SLT received CO/PBX incoming ring

##### Winking LED (Attendant can Override)

- Do not disturb

### 3. DSS/BLF Function Button LED Indications

	LED OFF	STEADY LED
EXTERNAL AND INTERNAL PAGING	Idle	In Use
NIGHT TRANSFER	Day Mode	Night Mode
BUZZER OFF	Buzzer On	Buzzer Off
MESSAGE WAITING	Console Operates as DSS/BLF	Console can Set and Remove Message Waiting
TRANSFER	Not in use	Console can Camp-on or Transfer CO/PBX Call

NUMBERING PLAN FOR ELECTRA-16/48

DIAL

0	Call Attendant/Automatic Callback
1	ICM Tone Signal
2	Call Pickup
3	Night CO Call Pickup
7	CO Line Access – Class C
8	CO Line Access – Class B
9	CO Line Access – Class A
*	Last Number Redial/Tone Override Signal (or $\boxed{\begin{smallmatrix} \text{ADD} \\ \text{ON} \end{smallmatrix}} + *$ ).
#	Speed Dial Access/Set Callback Number Display (or $\boxed{\begin{smallmatrix} \text{ADD} \\ \text{ON} \end{smallmatrix}} + \#$ ).
40	Store Speed Dial Station with Single Line
41	Confirm Memory of Speed Dial – System (Attendant Keypad Only)
42	Remove Callback Number Display from All Keypads (Attendant Keypad Only)
45	Remove Call Forwarding from All Stations (Attendant Keypad Only)
46	Set or Reset Call Forwarding +1 call forwarding – all calls +2 call forwarding – busy
47	Display Call Forwarding Status
48	Enter Night Transfer (Attendant Keypad Only)
49	Cancel Night Transfer (Attendant Keypad Only)
50	Internal Page – All Zone
51	Internal Page – Zone 1
52	Internal Page – Zone 2
53	Internal Page – Zone 3
55	Meet-Me-Answer (Internal)
60	External Page – All Zone
61	External Page – Zone 1
62	External Page – Zone 2
63	External Page – Zone 3
65	Meet-Me-Answer – (External)
101 ~ 148	ICM Station Number
10 ~ 19	System Speed Dial Codes
20 ~ 29	Station Speed Dial Codes (Single Line Set Only)



